

B E E C H C R A F T
DUKE B60
I L L U S T R A T E D P A R T S C A T A L O G

LIST OF PAGES & TABLE OF CONTENTS
FOR
CHAPTER 57-00-00 WINGS

CHAP/SUB- SECT & UNIT	PAGE NO.	EFFECTIVE DATE	TABLE OF CONTENTS
57-00-00	1	04/19/84.	LIST OF PAGES & TABLE OF CONTENTS
57-00-00	2	04/19/84	
57-00-00	3	03/20/81	
57-10-01	1	03/20/81.	WING ASSEMBLY
57-10-01	2	03/20/81	P-247 THRU P-347,P-349 THRU P-364
57-10-01	3	03/20/81	
57-10-01	4	03/20/81	
57-10-01	5	01/08/82	
57-10-02	1	03/20/81.	WING ASSEMBLY
57-10-02	2	03/20/81	P-348,P-365 AND AFTER
57-10-02	3	03/20/81	
57-10-02	4	03/20/81	
57-10-02	5	03/20/81	
57-10-02	6	03/20/81	
57-10-02	7	03/20/81	
57-10-02	8	03/20/81	
57-10-02	9	01/08/82	
57-10-10	1	03/20/81.	WING BOX SECTION.
57-10-10	2	03/20/81	
57-10-10	3	03/20/81	
57-10-10	4	03/20/81	
57-10-10	5	01/08/82	
57-10-10	6	03/20/81	
57-10-10	7	03/20/81	
57-10-10	8	03/20/81	
57-10-10	9	03/20/81	
57-10-10	10	03/20/81	
57-10-10	11	03/20/81	
57-10-10	12	03/20/81	
57-10-10	13	04/16/82	
57-10-10	14	03/20/81	
57-10-10	15	04/16/82	
57-10-10	16	03/20/81	
57-10-10	17	03/20/81	
57-10-10	18	03/20/81	
57-10-10	19	03/20/81	
57-10-10	20	03/20/81	
57-10-10	21	01/08/82	
57-10-20	1	03/20/81.	WING FRONT SPAR
57-10-20	2	03/20/81	
57-10-20	3	01/08/82	
57-10-20	4	03/20/81	
57-10-20	5	01/08/82	
57-10-30	1	03/20/81.	WING REAR SPAR.
57-10-30	2	03/20/81	
57-10-30	3	03/20/81	
57-10-30	4	03/20/81	
57-10-30	5	03/20/81	
57-20-01	1	03/20/81.	WING INBOARD LEADING EDGE
57-20-01	2	03/20/81	P-247 THRU P-266
57-20-01	3	03/20/81	
57-20-01	4	03/20/81	
57-20-01	5	03/20/81	
57-20-01	6	03/20/81	
57-20-01	7	03/20/81	
57-20-01	8	03/20/81	
57-20-01	9	03/20/81	
57-20-01	10	03/20/81	
57-20-01	11	01/08/82	

B E E C H C R A F T
DUKE B60
I L L U S T R A T E D P A R T S C A T A L O G

LIST OF PAGES & TABLE OF CONTENTS
FOR
CHAPTER 57-00-00 WINGS

CHAP/SUB- SECT & UNIT	PAGE NO.	EFFECTIVE DATE	TABLE OF CONTENTS
57-20-02	1	03/20/81	WING INBOARD LEADING EDGE
57-20-02	2	03/20/81	P-267 AND AFTER
57-20-02	3	03/20/81	
57-20-02	4	03/20/81	
57-20-02	5	01/08/82	
57-20-02	6	03/20/81	
57-20-02	7	03/20/81	
57-20-02	8	03/20/81	
57-20-02	9	01/08/82	
57-20-02	10	03/20/81	
57-20-02	11	01/08/82	
57-20-10	1	03/20/81	WING OUTBOARD LEADING EDGE.
57-20-10	2	03/20/81	P-247 THRU P-266
57-20-10	3	03/20/81	
57-20-10	4	03/20/81	
57-20-10	5	03/20/81	
57-20-11	1	03/20/81	WING OUTBOARD LEADING EDGE.
57-20-11	2	03/20/81	P-267 AND AFTER
57-20-11	3	03/20/81	
57-20-11	4	03/20/81	
57-20-11	5	03/20/81	
57-20-20	1	03/20/81	WING TRAILING EDGE.
57-20-20	2	03/20/81	
57-20-20	3	03/20/81	
57-20-20	4	03/20/81	
57-20-20	5	03/20/81	
57-20-20	6	03/20/81	
57-20-20	7	03/20/81	
57-20-30	1	03/20/81	WING TIP/EXTENDED/.
57-20-30	2	03/20/81	
57-20-30	3	01/08/82	
57-20-30	4	03/20/81	
57-20-30	5	01/08/82	
57-20-30	6	03/20/81	
57-20-30	7	01/08/82	
57-20-31	1	03/20/81	WET WING TIP/OPTIONAL/.
57-20-31	2	03/20/81	P-348,P-365 AND AFTER
57-20-31	3	03/20/81	
57-20-31	4	03/20/81	
57-20-31	5	03/20/81	
57-20-31	6	04/19/84	
57-20-31	7	04/19/84	
57-30-01	1	03/20/81	WING SKINS.
57-30-01	2	01/08/82	
57-30-01	3	04/16/82	
57-30-01	4	01/08/82	
57-30-01	5	03/20/81	
57-30-10	1	03/20/81	WING FAIRINGS
57-30-10	2	03/20/81	
57-30-10	3	03/20/81	
57-40-01	1	03/20/81	WING INSTALLATION
57-40-01	2	04/19/84	
57-40-01	3	04/19/84	
57-40-01	4	04/19/84	
57-40-01	5	04/19/84	

B E E C H C R A F T
DUKE B60
I L L U S T R A T E D P A R T S C A T A L O G

LIST OF PAGES & TABLE OF CONTENTS
FOR
CHAPTER 57-00-00 WINGS

SYS/SUB-SYS/ CHAP SECTION	PAGE NO.	EFFECTIVE DATE	TABLE OF CONTENTS
57-50-01	1	03/20/81 FLAPS
57-50-01	2	03/20/81	
57-50-01	3	03/20/81	
57-50-01	4	03/20/81	
57-50-01	5	03/20/81	
57-50-10	1	03/20/81 AILERON AND AILERON TAB
57-50-10	2	03/20/81	
57-50-10	3	03/20/81	
57-50-10	4	03/20/81	
57-50-10	5	03/20/81	
57-50-10	6	03/20/81	
57-50-10	7	03/20/81	

BEECHCRAFT
DUKE B60
ILLUSTRATED PARTS CATALOG

57-10-01
WING ASSEMBLY
P-247 THRU P-347, P-349 THRU P-364

BEECHCRAFT
DUKE B60
ILLUSTRATED PARTS CATALOG

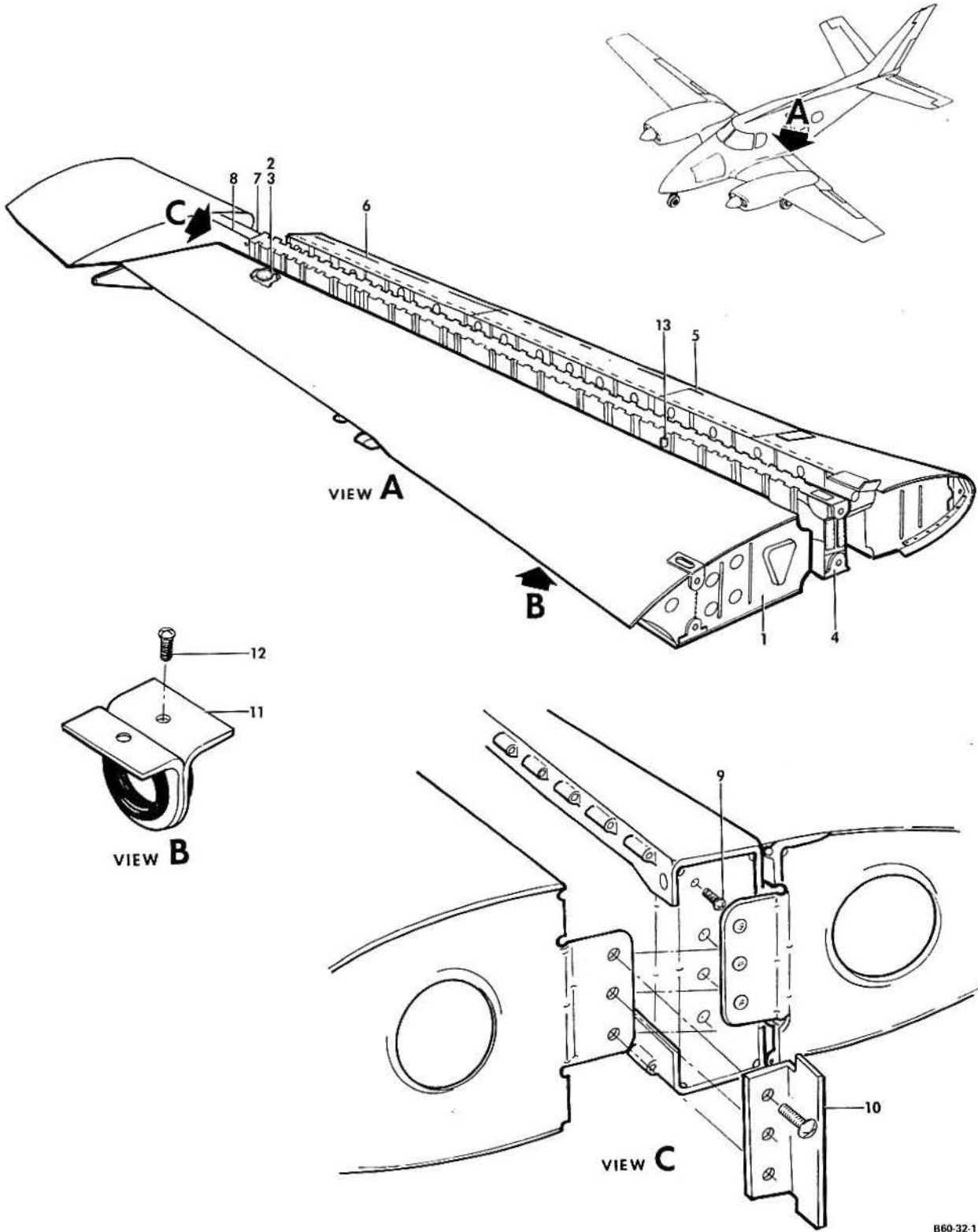

B60-32-1

B E E C H C R A F T
DUKE B60
I L L U S T R A T E D P A R T S C A T A L O G

GAMA/ATA CODE & INDEX NO.	PART NO.	DESCRIPTION							UNITS PER ASSY	USABLE ON CODE
		1	2	3	4	5	6	7		
10-01	60-110000-605	WING ASSY,LH/LESS FLAP AND AILERON/	1	5
	60-110000-606	WING ASSY,RH/LESS FLAP AND AILERON/	1	5
	95-110014-753	. WING MAIN SECTION ASSY,LH/COMPLETE/	1	5
	95-110014-754	. WING MAIN SECTION ASSY,RH/COMPLETE/	1	5
- 1	95-110014-755	. . BOX SECTION ASSY,MAIN WING LH	1	5
		/SEE CHAPTER 57-10-10/								
	95-110014-756	. . BOX SECTION ASSY,MAIN WING RH	1	5
		/SEE CHAPTER 57-10-10/								
	95-110014-937	. . CONDUIT	1	5
	115005-1	. . GROMMET	8	5
	766-6	. . CLAMP	5	5
		/ATTACHING PARTS/								
	MS27039-0804	. . SCREW	1	
	AN960-8	. . WASHER	1	
	130909N28	. . NUT	1	
		-----*								
	50-920077	. . VENT ASSY,FUEL	1	5
- 2	95-110014-253	. . DOOR	1	5
		/ATTACHING PARTS/								
- 3	AN507B832R8	. . SCREW	6	
		-----*								
	95-110014-425	. . SKIN,RH TRAILING EDGE	1	5
	95-110014-431	. . SKIN,RH TRAILING EDGE	1	5
	60-110012-605	. WING LEADING EDGE AND FRONT SPAR ASSY,LH	NP	1
		/ORDER 60-110012-609/								
	60-110012-606	. WING LEADING EDGE AND FRONT SPAR ASSY,RH	NP	1
		/ORDER 60-110012-610/								
	60-110012-609	. WING LEADING EDGE AND FRONT SPAR ASSY,LH	1	2
	60-110012-610	. WING LEADING EDGE AND FRONT SPAR ASSY,RH	1	2
- 4	000-110011-7	. . FRONT SPAR ASSY,LH/SEE CHAPTER 57-10-20/	1	5
	000-110011-8	. . FRONT SPAR ASSY,RH/SEE CHAPTER 57-10-20/	1	5
	60-110012-607	. . LEADING EDGE ASSY,LH INBD WING	NP	1
		/ORDER 60-110012-611/SEE CHAPTER 57-20-								
	60-110012-608	. . LEADING EDGE ASSY,RH INBD WING	NP	1
		/ORDER 60-110012-612/SEE CHAPTER 57-20-								
- 5	60-110012-611	. . LEADING EDGE ASSY,LH INBD WING	1	2
		/SEE CHAPTER 57-20-02/								
	60-110012-612	. . LEADING EDGE ASSY,RH INBD WING	1	2
		/SEE CHAPTER 57-20-02/								
	96-100016-621	. . LEADING EDGE ASSY,LH OUTBD WING	NP	1
		/ORDER 000-110029-609/SEE CHAPTER 57-20								
	96-100016-622	. . LEADING EDGE ASSY,RH OUTBD WING	NP	1
		/ORDER 000-110029-610/SEE CHAPTER 57-20								
- 6	000-110029-609	. . LEADING EDGE ASSY,LH OUTBD WING	1	2
		/SEE CHAPTER 57-20-11/								
	000-110029-610	. . LEADING EDGE ASSY,RH OUTBD WING	1	2
		/SEE CHAPTER 57-20-11/								
- 7	105774C-ZG18700	. PIN,HINGE/MAIN SPAR FWD UPPER & LOWER/	2	3
- 8	105774C-ZG17004	. PIN,HINGE/MAIN SPAR FWD UPPER & LOWER/	2	4
- 8	105774C-ZG17004	. PIN,HINGE/MAIN SPAR AFT UPPER & LOWER/	2	5
- 9	MS27039-0809	. SCREW,PIN LOCK	2	5
	AN960D8	. . WASHER	4	5
	NAS1329H08K75L	. . NUT	2	5
- 10	000-170030-1	. ANGLE,TIE/STA 199.9/	1	4
- 11	35-115232	. LUG ASSY,WING TIE DOWN/STA 131.674/	1	5
		/ATTACHING PARTS/								
- 12	NAS221-9	. SCREW	4	
		-----*								
- 13	60-110000-11	. PLATE,TIE	1	5

BEECHCRAFT
DUKE 860
ILLUSTRATED PARTS CATALOG

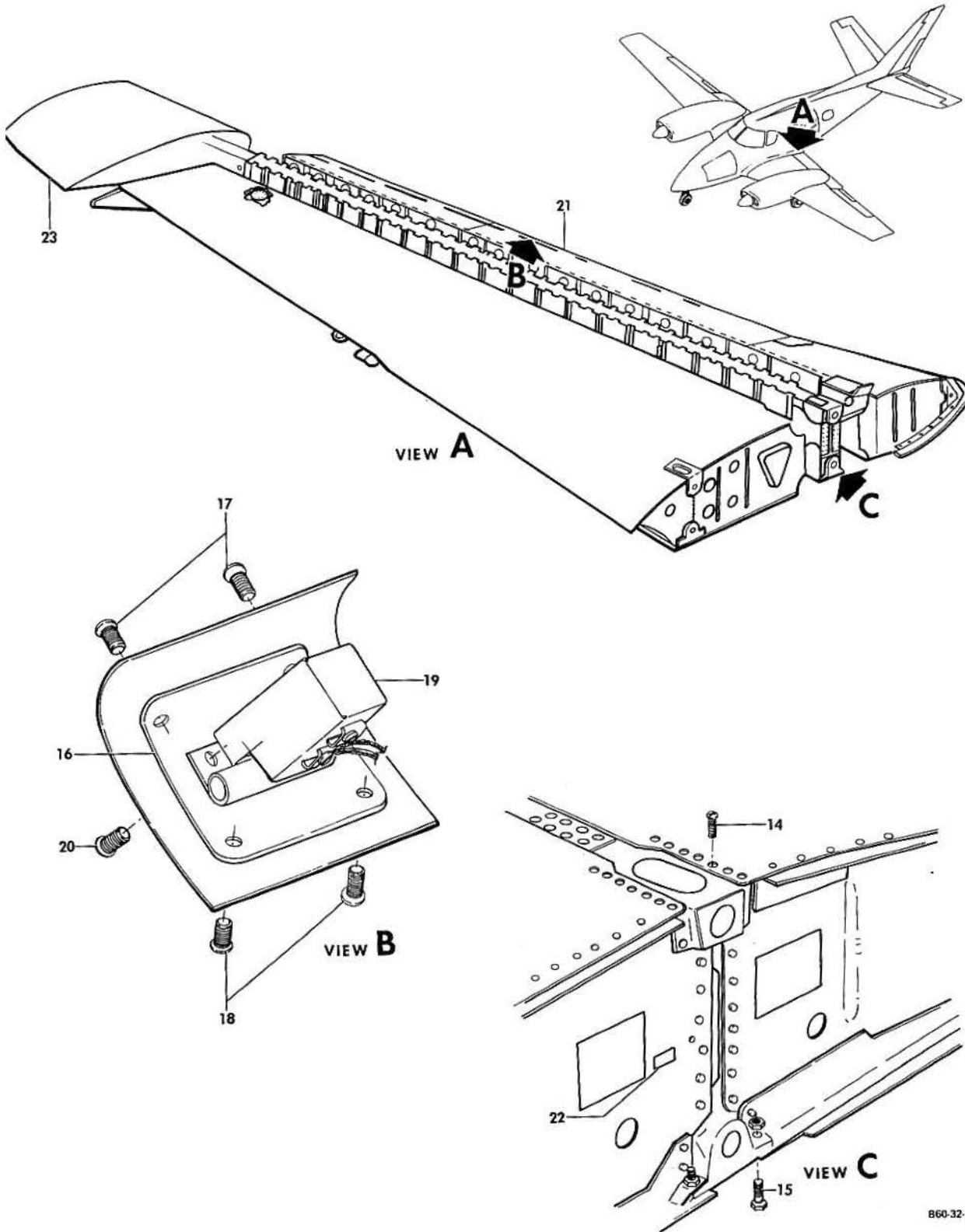

B E E C H C R A F T
DUKE B60
I L L U S T R A T E D P A R T S C A T A L O G

GAMA/ATA CODE & INDEX NO.	PART NO.	1	2	3	4	5	6	7	DESCRIPTION	UNITS PER ASSY	USABLE ON CODE
10-01 - 14	MS27039-1	SCREW	14	5
	AN960-10	WASHER	14	5
	130909N29	NUT	14	5
- 15	MS27039-08	SCREW	18	5
	AN960-8	WASHER	18	5
	130909N28	NUT	18	5
	151-101-3	DOUBLER,STALL WARNING DETECTOR.	1	1
		/ATTACHING PARTS/		
	MS24693S28	SCREW	4	
	190-2	DETECTOR UNIT,STALL WARNING/W/O DEICER/	1	1
	190-1	DETECTOR UNIT,STALL WARNING/WITH DEICER/.	1	1
	58-361013-7	DETECTOR INSTL,STALL WARNING/W-O DEICER/.	NP	2
	58-361013-9	DETECTOR INSTL,STALL WARNING/WITH DEICER/	NP	2
- 16	151-202-1	PLATE,MOUNTING/DETECTOR/W-O DEICE/.	1	2
	151-202-2	PLATE,MOUNTING/DETECTOR/WITH DEICE/	1	2
		/ATTACHING PARTS/		
- 17	MS24693S29	SCREW	2	
- 18	AN531-6R8	SCREW	2	
- 19	190-3	DETECTOR UNIT,STALL WARNING	1	2
		/ATTACHING PARTS/		
- 20	MS24693S29	SCREW	2	
	AN960-6	WASHER	2	
	MS21044N06	NUT	2	
- 21	60-110012-65	STALL STRIP,LH/WITHOUT DEICER/.	1	5
	130421-01050	STALL STRIP,LH/WITH DEICER/	1	5
	60-110012-67	STALL STRIP,RH/WITHOUT DEICER/.	1	5
	130421-00762	STALL STRIP,RH/WITH DEICER/	1	5
- 22	103637	PLACARD,WING IDENTIFICATION	1	5
		/ATTACHING PARTS/		
	49384	FASTENER	2	
	R 000-017000-33	TIP INSTL,LH WING	NP	6
	R 000-170000-7	TIP ASSY,LH WING	1	7
	R 000-017000-34	TIP INSTL,RH WING	NP	6
	R 000-170000-6	TIP ASSY,RH WING	1	7
- 23	R 000-017000-5	TIP ASSY,LH WING/SEE CHAPTER 57-20-30/.	1	6
	R 000-170000-1	STRUCTURE ASSY,LH TIP	1	7
	R 000-017000-6	TIP ASSY,RH WING/SEE CHAPTER 57-20-30/.	1	6
	R 000-170000-2	STRUCTURE ASSY,RH TIP	1	7
		/ATTACHING PARTS/		
	MS27039C0807	SCREW	2	
R	MS27039C0809	SCREW	8	6
R	MS27039C0809	SCREW	10	7
	MS27039C0806	SCREW	7	
R	MS27039C0808	SCREW	37	6
R	MS27039C0808	SCREW	32	7
	AN960PD8L	WASHER	77	
	MS21045C08	NUT	31	
	60-360017-601	CABLE ASSY,WING TIP ELECTRICAL.	1	5
	60-980000-613	NACELLE ASSY,LH WING/SEE CHAPTER 54-10-01/.	1	5
	60-980000-614	NACELLE ASSY,RH WING/SEE CHAPTER 54-10-01/.	1	5
	60-360001-669	WIRE HARNESS,LH WING.	1	5
	60-360001-670	WIRE HARNESS,RH WING.	1	5

CODES OF EFFECTIVITY

1	P-247 THRU P-266	2	P-267 THRU P-347 P-349 THRU P-364
3	P-247 THRU P-249	4	P-250 THRU P-347 P-349 THRU P-364
5	P-247 THRU P-347 P-349 THRU P-364	6	P-247 THRU P-309
7	P-310 THRU P-347 P-349 THRU P-364		

BEECHCRAFT
DUKE B60
ILLUSTRATED PARTS CATALOG

57-10-02
WING ASSEMBLY
P-348,P-365 AND AFTER

BEECHCRAFT
DUKE B60
ILLUSTRATED PARTS CATALOG

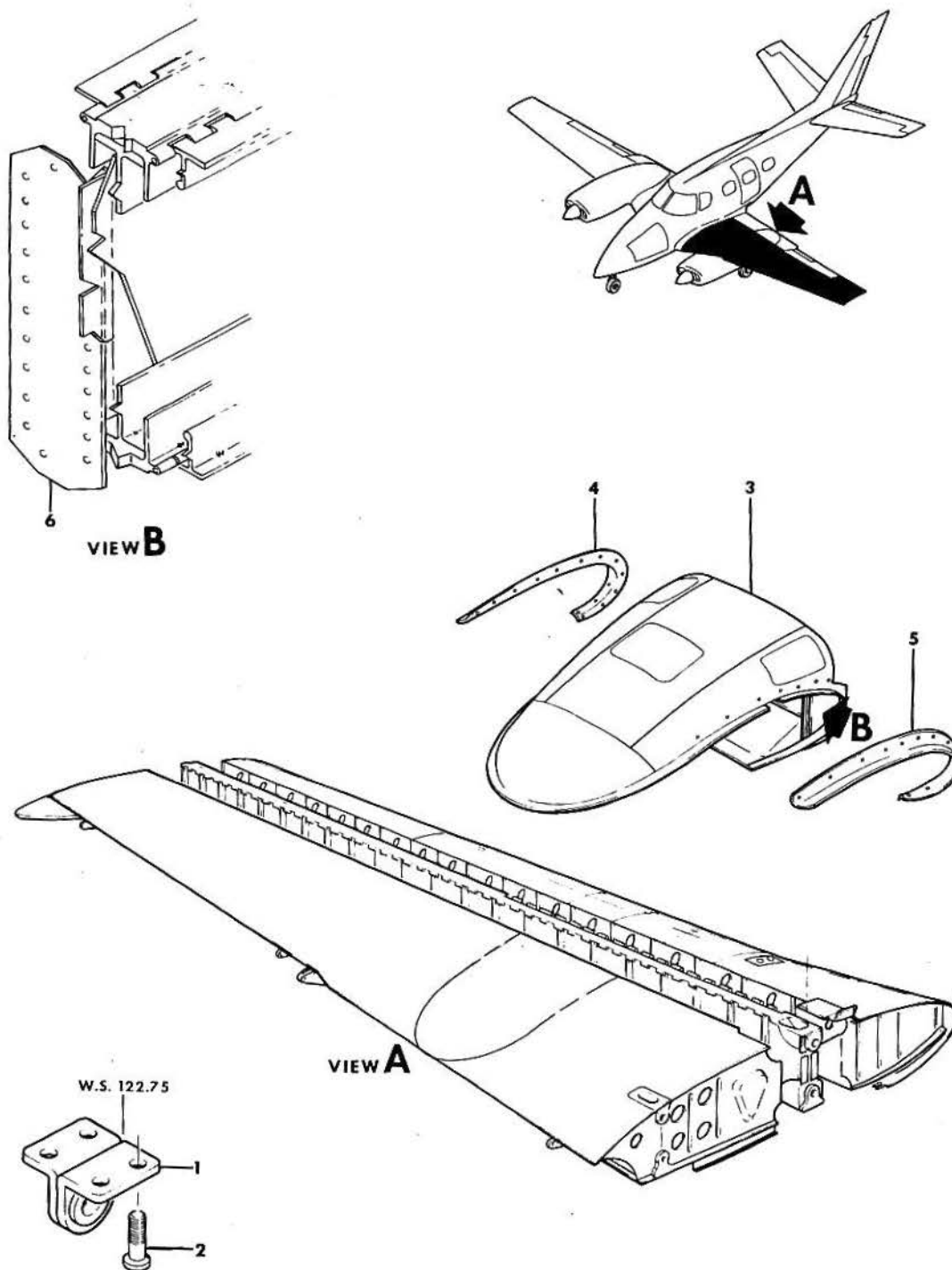

B60-32-4

B E E C H C R A F T
DUKE B60
I L L U S T R A T E D P A R T S C A T A L O G

GAMA/ATA CODE & INDEX NO.	PART NO.	DESCRIPTION							UNITS PER ASSY	USABLE ON CODE
		1	2	3	4	5	6	7		
10-02	60-110000-607	WING ASSY,LH/LESS FLAP AND AILERON/	1	1
	60-110000-608	WING ASSY,RH/LESS FLAP AND AILERON/	1	1
NOTE THE FOLLOWING PARTS LIST IS NOT THE COMPL ASSY BREAKDOWN OF THE COMPONENT PARTS OF THE ABOVE SPARES ASSY.SEE CHAPTER 27 FOR FLIGHT CONTROLS,CHAPTER 28 FOR FUEL, CHAPTER 54 FOR NACELLE ASSY,CHAPTER 71 FOR PDWER PLANT AND OTHER APPROPRIATE CHAPTERS FOR ADDITIONAL OPT. EQUIPMENT.										
- 1	35-115232	. LUG ASSY,WING TIE DOWN/WS122.750/	1	1
- 2	MS27039-1-09	. SCREW/ALSO USED AS SPARES REPL FOR NAS221-9/	4	
- 3	60-980000-613	. NACELLE ASSY,LH/WS70.34/SEE CHAPTER 54-10-01/	1	1
	60-980000-614	. NACELLE ASSY,RH/WS70.34/SEE CHAPTER 54-10-01/	1	1
	60-980000-289	. STRIP,RUBBER/NACELLE/	1	1
- 4	60-100014-7	. FILLET,LH OUTBD/WING NACELLE/	1	1
	60-100014-8	. FILLET,RH OUTBD/WING NACELLE/	1	1
	AN509-8R7	. SCREW	16	
	NAS1329A08K75	. NUT	16	
- 5	60-100015-7	. FILLET,LH INBD/WING NACELLE/	1	1
	60-100015-8	. FILLET,RH INBD/WING NACELLE/	1	1
	AN509-8R7	. SCREW	16	
	NAS1329A08K75	. NUT	16	
- 6	60-980000-205	. PLATE,TIE/WING NACELLE/	2	1

BEECHCRAFT
DUKE B60
ILLUSTRATED PARTS CATALOG

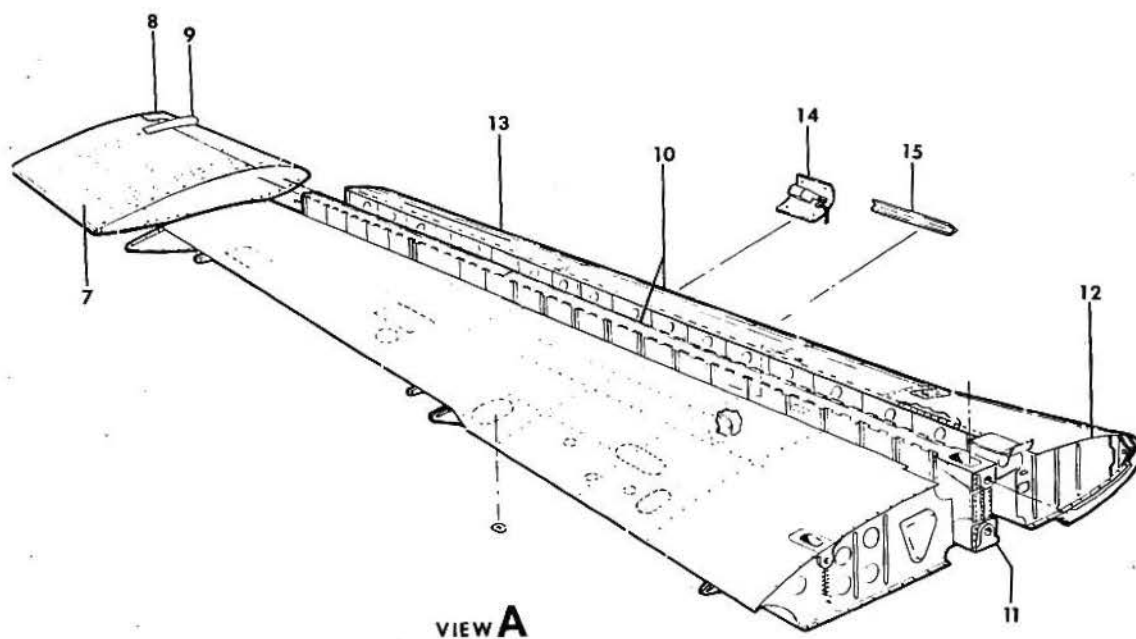

B60-32-5

B E E C H C R A F T
DUKE B60
I L L U S T R A T E D P A R T S C A T A L O G

GAMA/ATA CODE & INDEX NO.	PART NO.	DESCRIPTION							UNITS PER ASSY	USABLE ON CODE
		1	2	3	4	5	6	7		
10-02 - 7	000-170000-71	. WING TIP ASSY,LH EXTENDED/STD/WS191.00/	1	1	
		/SEE CHAPTER 57-20-30/			
	000-170000-72	. WING TIP ASSY,RH EXTENDED/STD/WS191.00/	1	1	
		/SEE CHAPTER 57-20-30/			
	60-170010-603	. WING TIP ASSY,LH WET/OPT/WS191.00/	1	1	
		/SEE CHAPTER 57-20-31/			
	60-170010-604	. WING TIP ASSY,RH WET/OPT/WS191.00/	1	1	
		/SEE CHAPTER 57-20-31/			
- 8	000-170000-53	. . COVER LENS,LH WING TIP.	1	1	
	000-170000-54	. . COVER LENS,RH WING TIP.	1	1	
		/ATTACHING PARTS/			
	MS15985-8R7	. . SCREW	2		
	AN960P08L	. . WASHER	2		
	MS21069L08K	. . NUTPLATE	2		
		-----			
	000-170000-37	. . HARNESS,LH NAV LIGHT/RED/	1	1	
	000-170000-38	. . HARNESS,RH NAV LIGHT/GREEN/	1	1	
		/ATTACHING PARTS/			
	MS24693-S5	. . SCREW	2		
	MS35206-216	. . SCREW	1		
- 9	000-170000-73	. . GLARESHIELD,LH WING TIP/WS227.10/	1	7	
	000-170000-74	. . GLARESHIELD,RH WING TIP/WS227.10/	1	7	
	000-170000-23	. . GLARESHIELD,LH WING TIP/WS227.10/	1	6	
	000-170000-24	. . GLARESHIELD,RH WING TIP/WS227.10/	1	6	
- 10	60-110012-631	. LEADING EDGE AND FRONT SPAR ASSY,LH WING.	1	4	
	60-110012-632	. LEADING EDGE AND FRONT SPAR ASSY,RH WING.	1	4	
	60-110012-627	. LEADING EDGE AND FRONT SPAR ASSY,LH WING.	1	2	
	60-110012-628	. LEADING EDGE AND FRONT SPAR ASSY,RH WING.	1	2	
- 11	000-110011-33	. . FRONT SPAR ASSY,LH/SEE CHAPTER 57-10-20/	1	1	
	000-110011-34	. . FRONT SPAR ASSY,RH/SEE CHAPTER 57-10-20/	1	1	
	000-110011-7	. . FRONT SPAR ASSY,LH.	1	1	
	000-110011-8	. . FRONT SPAR ASSY,RH.	1	1	
	000-110011-25	. . FRONT SPAR ASSY,LH/USE W OPT WET WING TIP/	1	1	
	000-110011-26	. . FRONT SPAR ASSY,RH/USE W OPT WET WING TIP/	1	1	
- 12	60-110012-629	. . LEADING EDGE ASSY,LH WING/INBD/	1	4	
		/SEE CHAPTER 57-20-02/			
	60-110012-630	. . LEADING EDGE ASSY,RH WING/INBD/	1	4	
		/SEE CHAPTER 57-20-02/			
	60-110012-611	. . LEADING EDGE ASSY,LH WING/INBD/	1	2	
	60-110012-612	. . LEADING EDGE ASSY,RH WING/INBD/	1	2	
- 13	000-110029-59	. . LEADING EDGE ASSY,LH WING/OUTBD/	1	4	
		/SEE CHAPTER 57-20-11/			
	000-110029-60	. . LEADING EDGE ASSY,RH WING/OUTBD/	1	4	
		/SEE CHAPTER 57-20-11/			
	000-110029-609	. . LEADING EDGE ASSY,LH WING/OUTBD/	1	2	
		/SEE CHAPTER 57-20-11/			
	000-110029-610	. . LEADING EDGE ASSY,RH WING/OUTBD/	1	2	
		/SEE CHAPTER 57-20-11/				
- 14	151-202-2	. . PLATE,MOUNTING.	1	8	
	190-3	. . DETECTOR UNIT,STALL WARNING	1	8	
	191-52	. . DETECTOR UNIT,STALL WARNING	1	9	
		/ATTACHING PARTS/			
	MS24693S31	. . SCREW/USED WITH 190-3 UNIT/	2		
	MS35206-231	. . SCREW/USED WITH 191-52 UNIT/	2		
	AN960-6	. . WASHER/USED WITH 191-52 UNIT/	2		
	130290-4	. . NUT,CLIP/USED WITH 190-3 UNIT/	2		
	-----				
- 15	130421-01050	. . STRIP,LH STALL.	1	1	
	130421-00762	. . STRIP,RH STALL.	1	1	

BEECHCRAFT
DUKE B60
ILLUSTRATED PARTS CATALOG

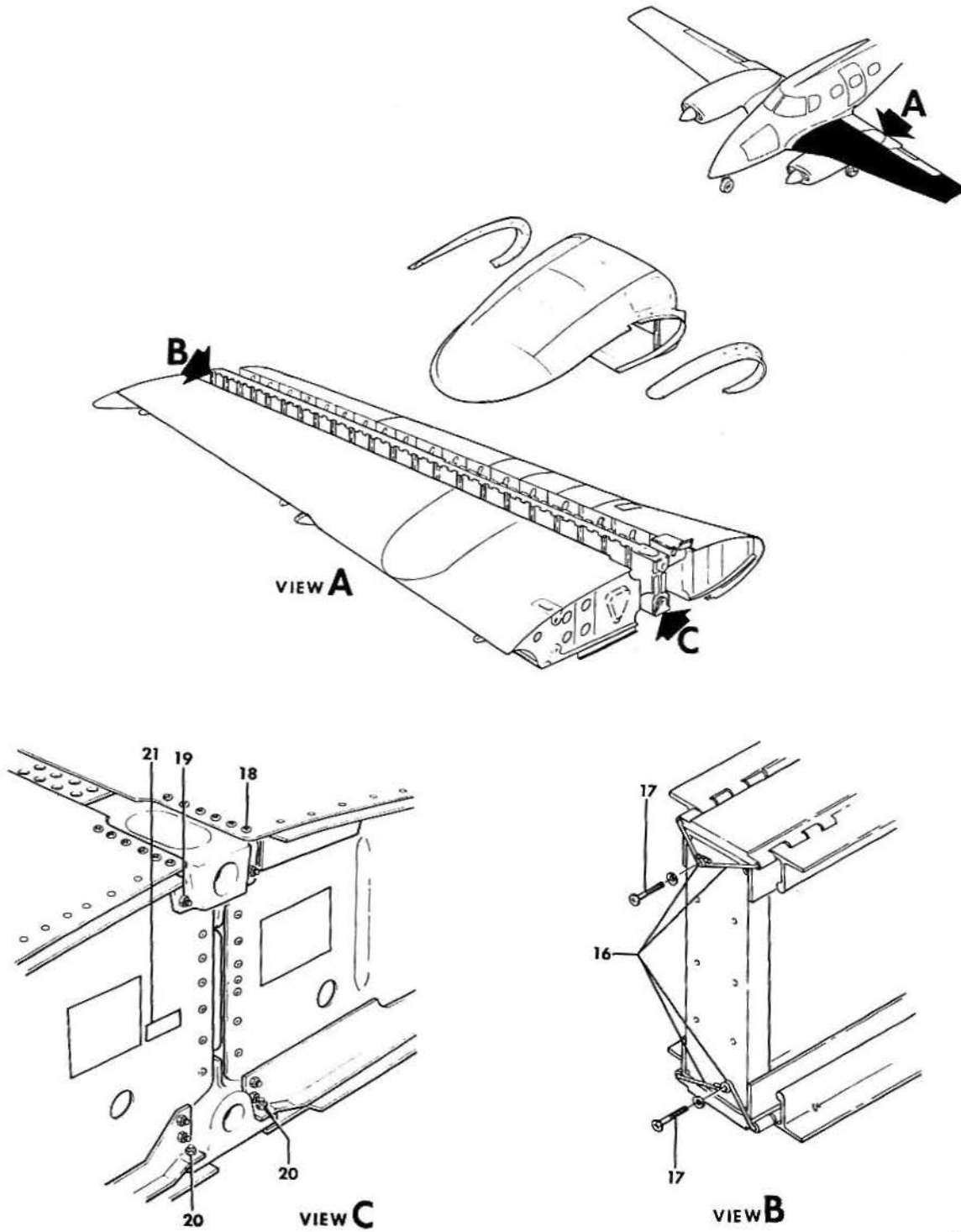

B60-32-6

B E E C H C R A F T
DUKE B60
I L L U S T R A T E D P A R T S C A T A L O G

GAMA/ATA CODE & INDEX NO.	PART NO.	DESCRIPTION							UNITS PER ASSY	USABLE ON CODE
		1	2	3	4	5	6	7		
10-02 - 16	105774C-ZG19000	. PIN,FWD AND AFT HINGE/UPPER AND LOWER/.	4	4
	105774C-ZG17004	. PIN,FWD AND AFT HINGE/UPPER AND LOWER/.	4	2
- 17	MS27039-0809	. /ATTACHING PARTS/	2	
	AN960D8	. SCREW,PIN LOCK.	4	
	NAS1329H08K75L	. WASHER.	2	
- 18	60-110000-11	. NUT	2	
	MS27039-1	. PLATE,TIE/MS70.34/.	1	1
	AN960-10	. SCREW/USED ON UPPER AND LOWER SPAR ADAPTER/	28	1
	130909N29	. WASHER.	28	1
- 19	MS27039-08	. NUT	28	1
	AN960-8	. SCREW/USED ON UPPER AND LOWER SPAR ADAPTER/	8	1
	130909N28	. WASHER.	8	1
- 20	MS27039-08	. NUT	8	1
	AN960-8	. SCREW	2	1
	130909N28	. WASHER.	4	1
- 21	103637	. NUT	2	1
	49384	. PLACARD,WING IDENTIFICATION	1	1
	60-980041	. /ATTACHING PARTS/	2	
	95-110014-779	. FASTENER.	2	
	95-110014-780	. DOOR ASSY,EXTERNAL POWER RECEPTACLE	NP	1
	95-110014-1035	. /SEE CHAPTER 24-40-01/		
	58-100022-53	. MAIN SECTION CLEAN UP,LH WING	1	1
	115005-1	. MAIN SECTION CLEAN UP,RH WING	1	1
	766-6	. CONDUIT	1	2
	766-8	. CONDUIT	1	4
	MS27039-0804	. GROMMET	5	2
	AN960-8	. CLAMP	4	2
	130909N28	. CLAMP	2	4
	50-920077	. /ATTACHING PARTS/	2	
	LHMS-S10	. SCREW	2	
	MS35207-264	. WASHER.	2	
	AN960-10L	. NUT	2	
	130909N29	. VENT ASSY,FUEL.	1	1
	MS3367-1-9	. MOUNT,LTG HOLE.	2	1
	95-110014-425	. /ATTACHING PARTS/		
	95-110014-431	. SCREW	2	1
		. WASHER.	2	1
		. NUT	2	1
		. STRAP,TIE	2	1
		. SKIN,RH TRAILING EDGE	1	1
		. SKIN,RH TRAILING EDGE	1	1

BEECHCRAFT
DUKE 860
ILLUSTRATED PARTS CATALOG

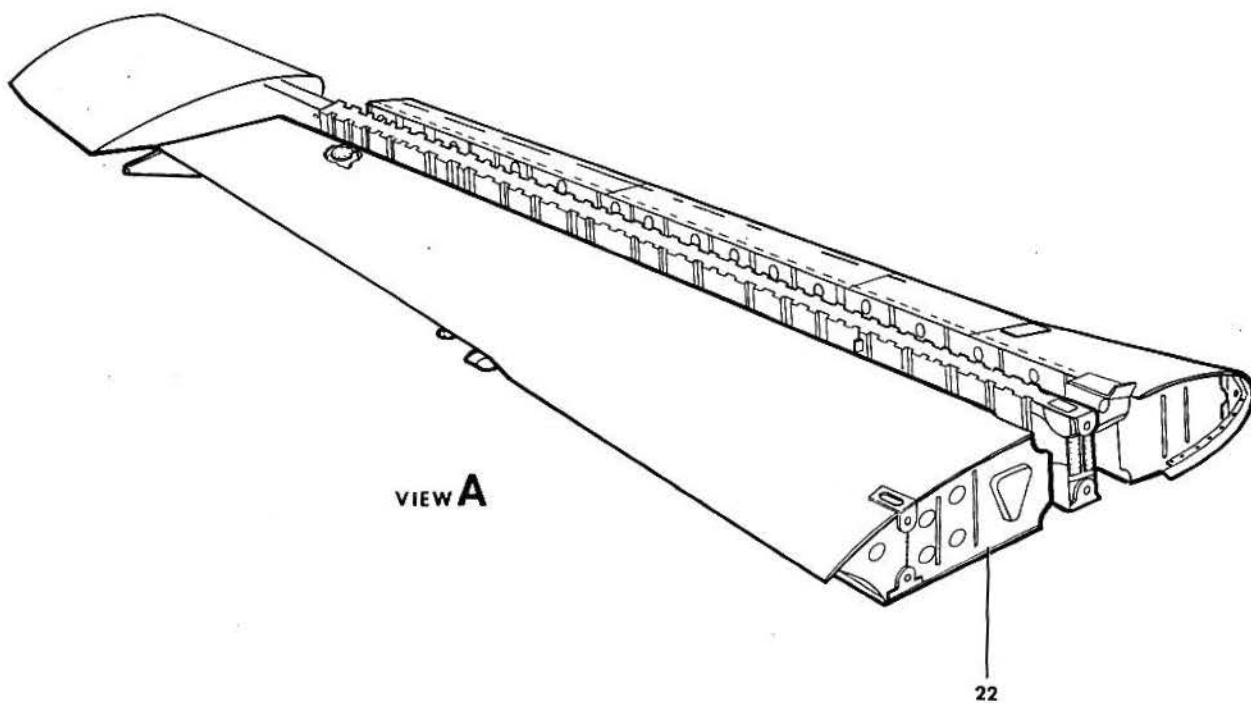
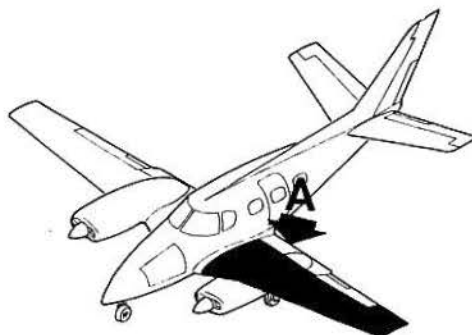

860-32-7

B E E C H C R A F T
DUKE B60
I L L U S T R A T E D P A R T S C A T A L O G

GAMA/ATA CODE & INDEX NO.	PART NO.	DESCRIPTION							UNITS PER ASSY	USABLE ON CODE
		1	2	3	4	5	6	7		
10-02 - 22	95-110014-775	.	.	BOX	SECTION	ASSY,LH	WING.	.	1	1
	95-110014-776	.	.	BOX	SECTION	ASSY,RH	WING.	.	1	1
	60-360001-669	.	.	HARNESS	ASSY,LH	WING.	.	1	1	
	60-360001-670	.	.	HARNESS	ASSY,RH	WING.	.	1	1	
	60-360017-601	.	.	CABLE	ASSY,STROBE	LIGHT	.	1	3	
	60-360017-621	.	.	CABLE	ASSY,STROBE	LIGHT	.	1	5	
	60-130001-605	.	.	AILERON	ASSY,LH	WING/SEE	CHAPTER 57-50-10/	.	1	1
	60-130001-163	.	.	AILERON	ASSY,RH	WING/SEE	CHAPTER 57-50-10/	.	1	1
	95-160000-609	.	.	FLAP	ASSY,LH	WING/SEE	CHAPTER 57-50-01/	.	1	1
	95-160000-610	.	.	FLAP	ASSY,RH	WING/SEE	CHAPTER 57-50-01/	.	1	1

CODES OF EFFECTIVITY

1	P-348, P-365 AND AFTER	2	P-348, P-365 THRU P-401
3	P-348, P-365 THRU P-432	4	P-402 AND AFTER
5	P-433 AND AFTER	6	P-348, P-365 THRU P-445
7	P-446 AND AFTER	8	P-348, P-365 THRU P-446
9	P-447 AND AFTER		

BEECHCRAFT
DUKE B60
ILLUSTRATED PARTS CATALOG

57-10-10
WING BOX SECTION

BEECHCRAFT
DUKE B60
ILLUSTRATED PARTS CATALOG

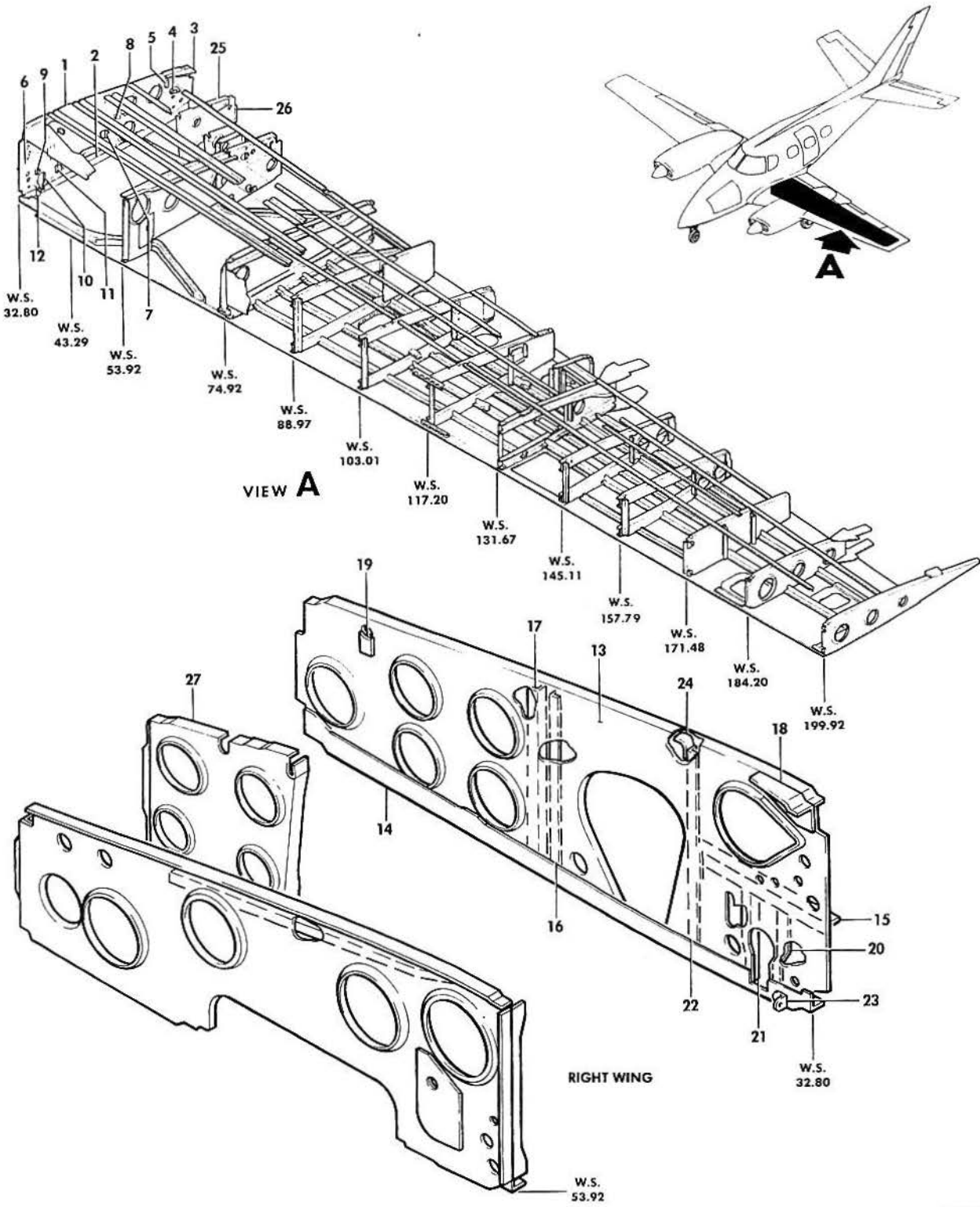

B60-36-1

B E E C H C R A F T
DUKE B60
I L L U S T R A T E D P A R T S C A T A L O G

GAMA/ATA CODE & INDEX NO.	PART NO.	1 2 3 4 5 6 7	DESCRIPTION	UNITS PER ASSY	USABLE ON CODE
10-10	95-110014-753		WING SECTION ASSEMBLY,LH MAIN	1	1
	95-110014-779		WING SECTION ASSEMBLY,LH MAIN	1	2
	95-110014-754		WING SECTION ASSEMBLY,RH MAIN	1	1
	95-110014-780		WING SECTION ASSEMBLY,RH MAIN	1	2
	95-110014-755		. BOX SECTION ASSY,LH WING.	1	1
	95-110014-775		. BOX SECTION ASSY,LH WING.	1	2
	95-110014-756		. BOX SECTION ASSY,RH WING.	1	1
	95-110014-776		. BOX SECTION ASSY,RH WING.	1	2
	95-110014-729		. . REAR SPAR & TRAILING EDGE ASSY,LH WING.	1	
			/SEE CHAPTER 57-20-20/		
	95-110014-730		. . REAR SPAR & TRAILING EDGE ASSY,RH WING.	1	
			/SEE CHAPTER 57-20-20/		
	95-110014-757		. . PANEL ASSY,LH WING.	1	1
	95-110014-777		. . PANEL ASSY,LH WING.	1	2
	95-110014-758		. . PANEL ASSY,RH WING.	1	1
	95-110014-778		. . PANEL ASSY,RH WING.	1	2
	60-110022-603		. . . RIB ASSY,LH/STA 32.805/	1	
- 1	60-110022-41		. . . RIB,LH.	1	
	NAS557-28		. . . GROMMET,LH.	1	
- 2	60-110022-47		. . . ANGLE,LH.	1	
- 3	95-110031-5		. . . GUSSET,LH.	1	
- 4	60-110022-37		. . . DOUBLER,LH.	1	
- 5	95-110031-9		. . . FAIRLEAD,LH.	1	
- 6	60-110022-43		. . . ANGLE,LH.	1	
- 7	60-110030-14		. . . ANGLE,LH.	1	
- 8	60-110030-16		. . . ANGLE,LH.	1	
- 9	60-110034-3		. . . ANGLE,LH.	1	
- 10	60-110035-3		. . . ANGLE,LH.	1	
- 11	60-110022-19		. . . ANGLE,LH.	1	
- 12	60-110039		. . . CLIP,LH.	1	
	60-110036-1		. . . CLIP,LH.	1	
	60-110037-1		. . . CLIP,LH.	1	
	35-115130-44		. . . SHIM.	1	3
	MS27039-1-07		. . . SCREW	4	
	AN960-10L		. . . WASHER.	4	
	MS21042L3		. . . NUT	4	
	60-110023-604		. . . RIB ASSY,RH/STA 32.805/	1	
- 13	60-110023-43		. . . RIB,RH.	1	
- 14	60-110023-49		. . . ANGLE,RH.	1	
- 15	60-110023-45		. . . ANGLE,RH.	1	
- 16	60-110030-13		. . . ANGLE,RH.	1	
- 17	60-110030-15		. . . ANGLE,RH.	1	
- 18	45-115076-8		. . . ANGLE,RH.	1	
- 19	95-110031-9		. . . FAIRLEAD,RH.	1	
- 20	60-110034-4		. . . ANGLE,RH.	1	
- 21	60-110035-4		. . . ANGLE,RH.	1	
- 22	60-110023-31		. . . ANGLE,RH.	1	
- 23	60-110039		. . . CLIP,RH.	1	
	60-110036-2		. . . CLIP,RH.	1	
	60-110037-2		. . . CLIP,RH.	1	
- 24	60-110023-29		. . . CLIP,RH.	1	
	35-115130-44		. . . SHIM.	1	3
	MS27039-1-07		. . . SCREW	4	
	AN960-10L		. . . WASHER.	4	
	MS21042L3		. . . NUT	4	
	60-110023-21		. . . GUSSET.	1	
	35-115070-24		. . . CLIP,LH/STA 32.8/	2	
	35-115070-25		. . . CLIP,RH/STA 32.8/	2	
	95-110030-601		. . . RIB ASSY,LH/STA 43.299/	1	
- 25	95-110030-1		. . . RIB,LH.	1	
- 26	95-110030-3		. . . DOUBLER,LH.	1	
	95-110030-7		. . . STOP,LH.	1	
	MS27980-68		. . . SOCKET,FASTENER	2	
	MS27980-88		. . . EYELET,FASTENER	2	
	60-110024-601		. . . RIB ASSY,RH/STA 43.299/	1	
- 27	60-110024-1		. . . RIB,RH.	1	
	MS27980-88		. . . EYELET,FASTENER	2	
	AN227-88		. . . STUD,FASTENER	2	

BEECHCRAFT
DUKE B60
ILLUSTRATED PARTS CATALOG

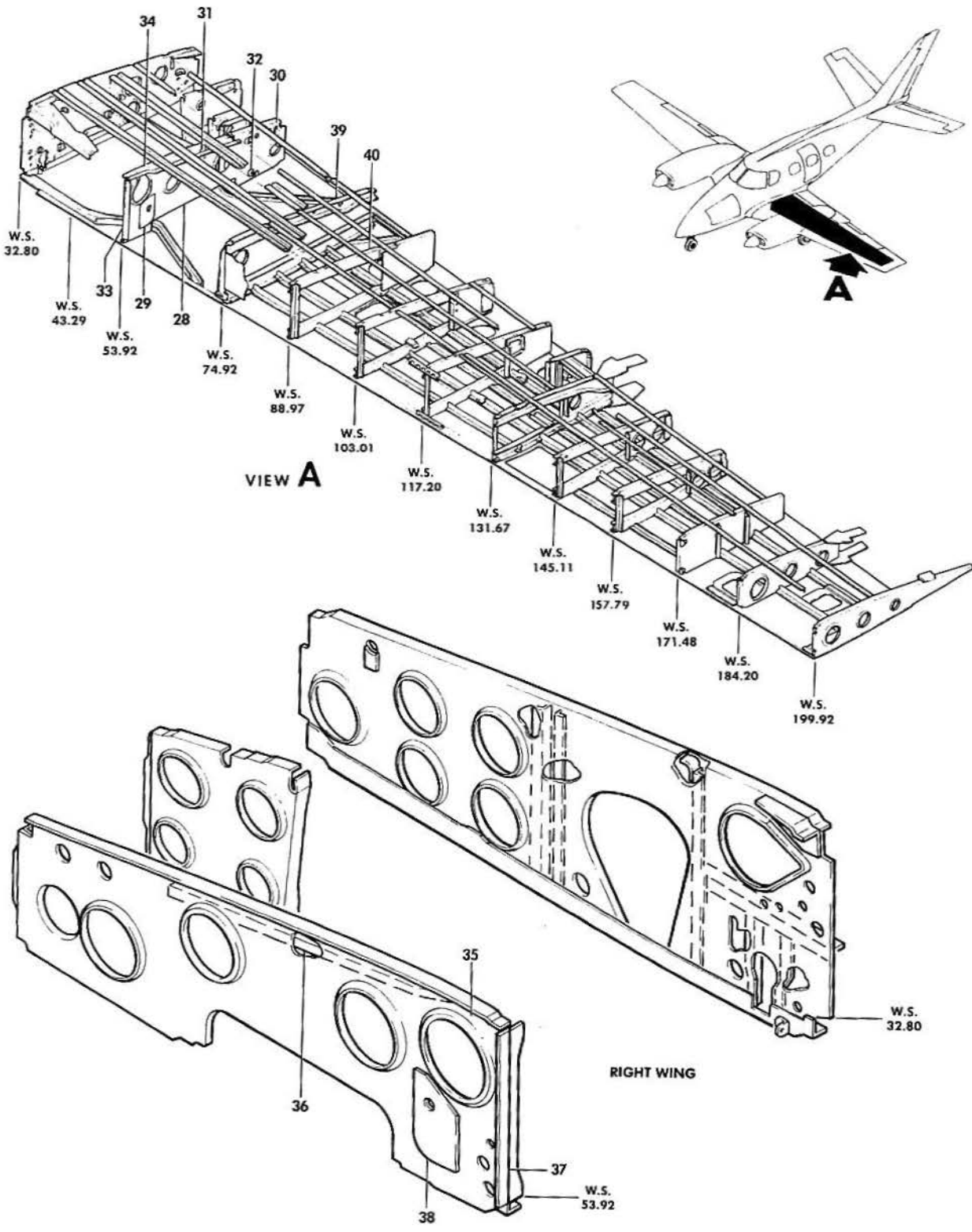

B60-36-2

B E E C H C R A F T
DUKE B60
I L L U S T R A T E D P A R T S C A T A L O G

GAMA/ATA CODE & INDEX NO.	PART NO.	DESCRIPTION							UNITS PER ASSY	USABLE ON CODE
		1	2	3	4	5	6	7		
10-10	95-110026-605	1	
- 28	95-110026-15	1	
- 29	95-110026-17	1	
- 30	95-110026-7	1	
- 31	95-110026-21	1	
- 32	35-115100-20	1	
- 33	35-115100-22	1	
- 34	95-110026-19	1	
	49160	1	
	R 95-110026-9	1	21
	MS35489-11	3	
	MS35489-6	2	
	MS27980-6B	3	
	MS27980-8B	3	
	22A17-82	1	
	MS35206-226	1	
	AN960-6L	1	
	MS21042L06	1	
	60-110025-602	1	
- 35	60-110025-1	1	
- 36	60-110025-3	1	
- 37	60-110025-5	1	
- 38	95-110026-17	1	
	MS35489-11	3	
	MS35489-6	2	
	MS27980-6B	3	
	MS27980-8B	3	
	22A17-82	1	
- 39	95-110023-611	1	
	95-110023-612	1	
	95-110023-31	1	
	95-110023-32	1	
	95-110023-5	1	
	95-110023-6	1	
	95-110023-7	1	
	95-110023-8	1	
	95-110023-9	1	
	95-110023-10	1	
	95-110023-11	1	
	95-110023-12	1	
	95-110023-13	1	
	95-110023-14	1	
	95-110023-15	1	
	95-110023-16	1	
	95-110023-17	1	
	95-110023-18	1	
	95-110023-19	1	
	95-110023-20	1	
	95-110023-25	1	
	95-110023-26	1	
	22A17-82	1	
	MS35206-245	2	
	AN960-8	2	
	MS21042L08	2	
	35-115051-16	1	
	35-115051-20	1	
	35-115051-21	1	
	115005-2	1	
- 40	R 95-110014-187	1	4
	95-110014-1027	1	5
	95-110014-188	1	4
	95-110014-1028	1	5
	95-110014-513	1	4
	95-110014-515	1	4

BEECHCRAFT
DUKE B60
ILLUSTRATED PARTS CATALOG

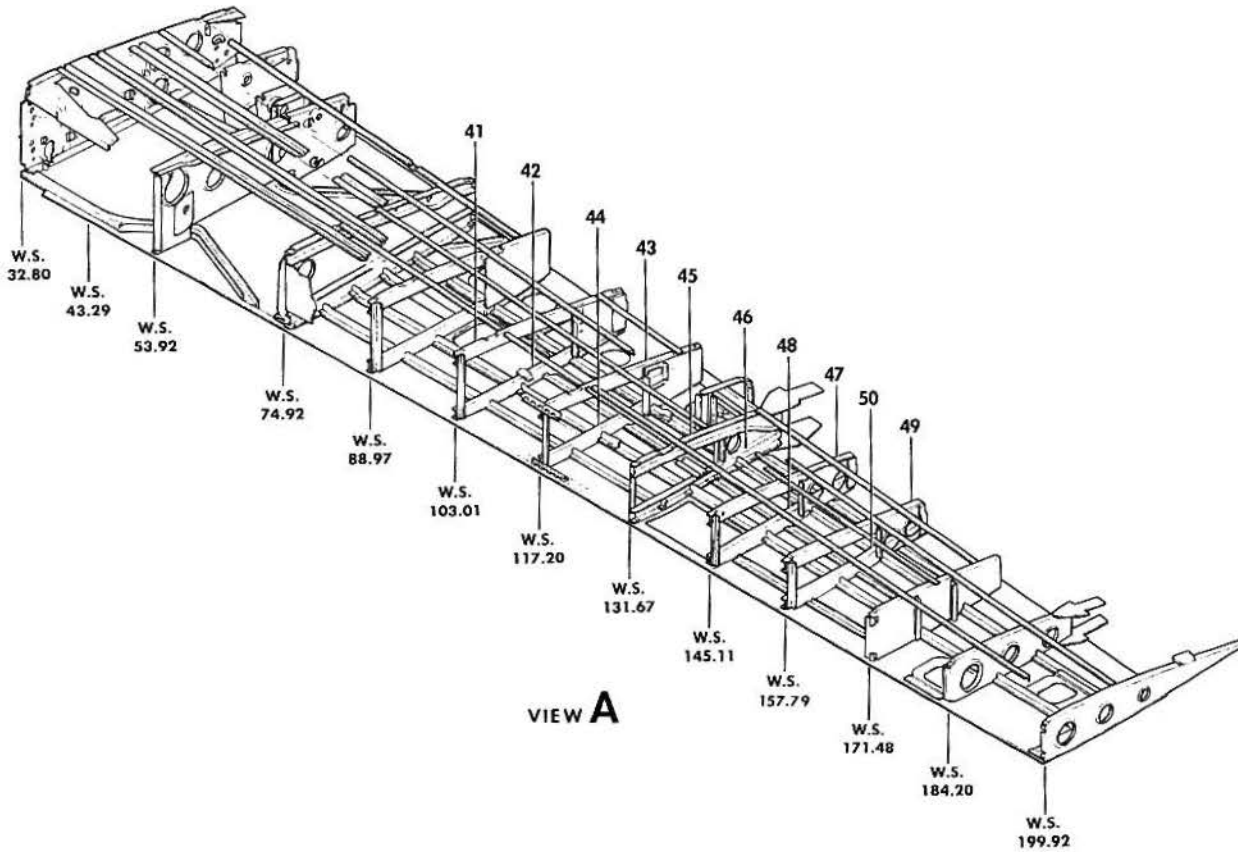
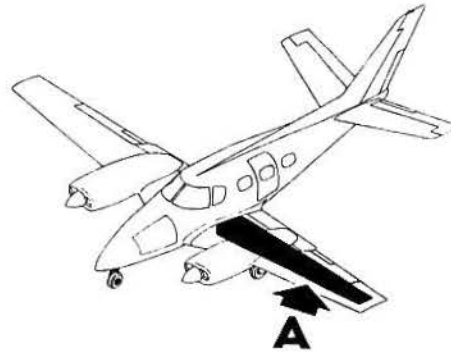

B60-36-3

B E E C H C R A F T
DUKE B60
I L L U S T R A T E D P A R T S C A T A L O G

GAMA/ATA CODE & INDEX NO.	PART NO.	1	2	3	4	5	6	7	DESCRIPTION	UNITS PER ASSY	USABLE ON CODE	
10-10 - 41	95-110014-623	.	.	.	RIB ASSY,LH/STA 103.018/.	1		
	95-110014-624	.	.	.	RIB ASSY,RH/STA 103.018/.	1		
	95-110014-175	.	.	.	WEB,LH.	1		
	95-110014-176	.	.	.	WEB,RH.	1		
	95-110014-177	.	.	.	FORMER,LH	1	17	
	95-110014-1087	.	.	.	FORMER,LH	1	18	
	95-110014-178	.	.	.	FORMER,RH	1	17	
	95-110014-1088	.	.	.	FORMER,RH	1	18	
	95-110014-181	.	.	.	ANGLE,LH.	1		
	95-110014-182	.	.	.	ANGLE,RH.	1		
	95-110014-319	.	.	.	FAIRLEAD.	1		
	- 42	95-110014-179	.	.	.	FORMER,LH/STA 103.018/.	1	
95-110014-180		.	.	.	FORMER,RH/STA 103.018/.	1		
- 43	95-110014-641	.	.	.	RIB ASSY,LH/STA 117.205/.	1		
	95-110014-642	.	.	.	RIB ASSY,RH/STA 117.205/.	1		
- 44	95-110014-281	.	.	.	CHANNEL,LH.	1		
	95-110014-282	.	.	.	CHANNEL,RH.	1		
	95-110014-289	.	.	.	WEB,LH.	1		
	95-110014-290	.	.	.	WEB,RH.	1		
	MS21047L08K	.	.	.	NUTPLATE,LH	1		
	95-110014-283	.	.	.	CHANNEL,LH/STA 117.205/	1		
	95-110014-284	.	.	.	CHANNEL,RH/STA 117.205/	1		
	95-110014-349	.	.	.	CLIP,LH	1		
	95-110014-350	.	.	.	CLIP,RH	1		
	- 45	95-110014-763	.	.	.	RIB ASSY,LH/STA 131.674/.	1	
95-110014-764		.	.	.	RIB ASSY,RH/STA 131.674/.	1		
95-110014-101		.	.	.	ANGLE,LH.	1		
95-110014-102		.	.	.	ANGLE,RH.	1		
95-110014-105		.	.	.	ANGLE,LH.	1		
95-110014-106		.	.	.	ANGLE,RH.	1		
95-110014-925		.	.	.	CHANNEL,LH.	1		
95-110014-926		.	.	.	CHANNEL,RH.	1		
95-110014-927		.	.	.	RIB,LH.	1		
95-110014-928		.	.	.	RIB,RH.	1		
- 46		95-110014-97	.	.	.	CHANNEL,LH/STA 131.674/	1	
		95-110014-98	.	.	.	CHANNEL,RH/STA 131.674/	1	
- 47	95-110014-615	.	.	.	RIB ASSY,LH/STA 145.112/.	1		
	95-110014-616	.	.	.	RIB ASSY,RH/STA 145.112/.	1		
	95-110014-79	.	.	.	ANGLE,LH.	1		
	95-110014-80	.	.	.	ANGLE,RH.	1		
	95-110014-81	.	.	.	FORMER,LH	1		
	95-110014-82	.	.	.	FORMER,RH	1		
	95-110014-91	.	.	.	WEB,LH.	1		
	95-110014-92	.	.	.	WEB,RH.	1		
	- 48	95-110014-87	.	.	.	FORMER,LH/STA 145.112/.	1	
		95-110014-88	.	.	.	FORMER,RH/STA 145.112/.	1	
- 49	95-110014-617	.	.	.	RIB ASSY,LH/STA 157.799/.	1		
	95-110014-618	.	.	.	RIB ASSY,RH/STA 157.799/.	1		
	95-110014-67	.	.	.	CHANNEL,LH.	1		
	95-110014-68	.	.	.	CHANNEL,RH.	1		
	95-110014-71	.	.	.	WEB,LH.	1		
	95-110014-72	.	.	.	WEB,RH.	1		
- 50	95-110014-75	.	.	.	ANGLE,LH.	1		
	95-110014-76	.	.	.	ANGLE,RH.	1		
	95-110014-69	.	.	.	CHANNEL,LH/STA 157.799/	1		
	95-110014-70	.	.	.	CHANNEL,RH/STA 157.799/	1		

BEECHCRAFT
DUKE B60
ILLUSTRATED PARTS CATALOG

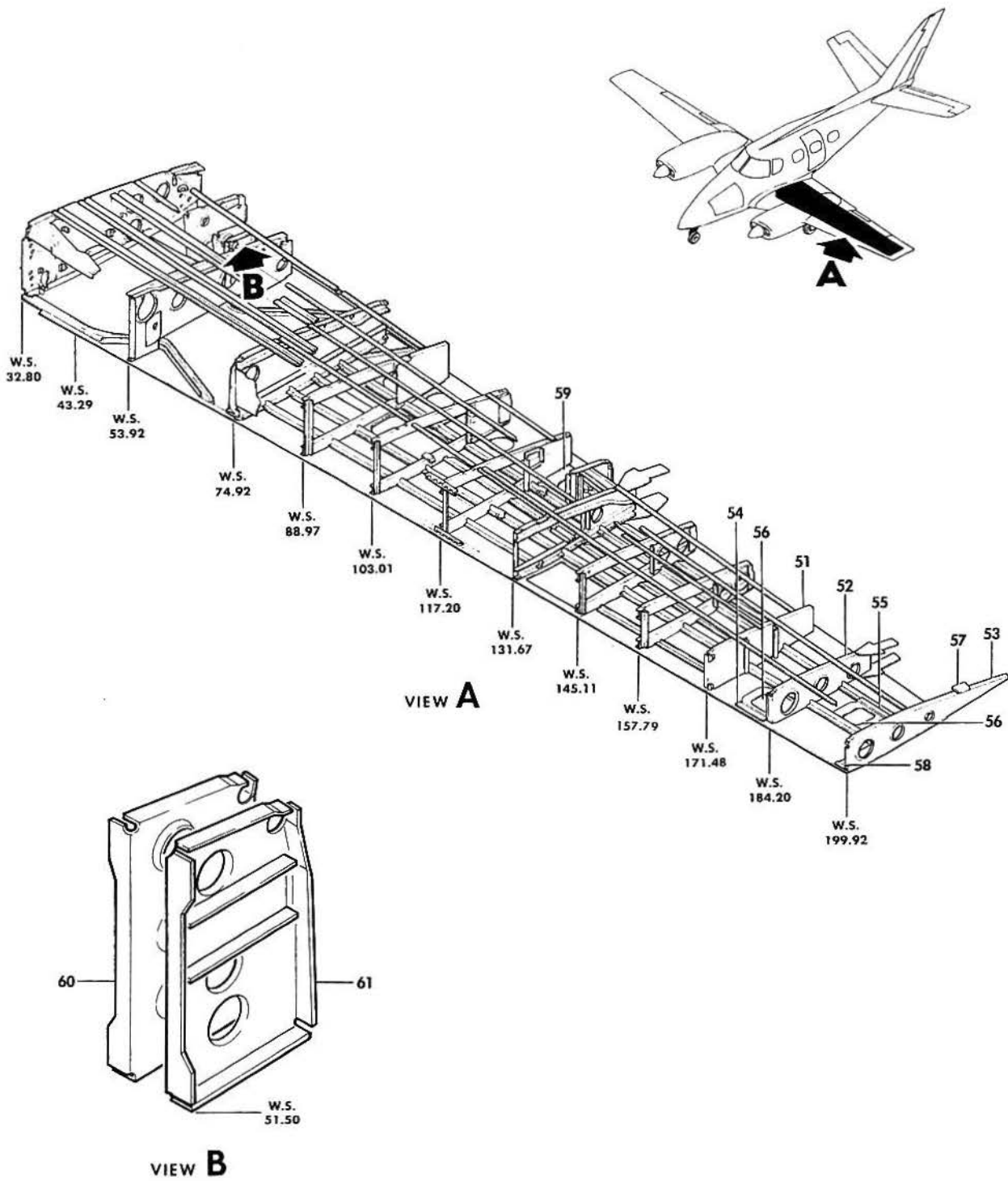

B60-36-4

B E E C H C R A F T
DUKE B60
I L L U S T R A T E D P A R T S C A T A L O G

GAMA/ATA CODE & INDEX NO.	PART NO.	DESCRIPTION							UNITS PER ASSY	USABLE ON CODE
		1	2	3	4	5	6	7		
10-10 - 51	95-110014-749	1	
	95-110014-750	1	
	95-110014-43	1	
	95-110014-44	1	
	95-110014-45	1	
	95-110014-46	1	
	95-110014-49	1	
	95-110014-50	1	
	95-110014-53	1	
	95-110014-54	1	
	95-110014-55	1	
	95-110014-56	1	
	95-110014-57	1	
	95-110014-58	1	
	95-110014-59	1	
	95-110014-157	1	
	95-110014-158	1	
	95-110014-805	1	
- 52	95-110014-639	1	6
	95-110014-771	1	7
	95-110014-640	1	6
	95-110014-772	1	7
	95-110014-39	1	6
	95-110014-1023	1	7
	95-110014-40	1	6
	95-110014-1024	1	7
	35-115032-6	1	
	35-115032-7	1	
- 53	95-110011-1	1	6
	95-110011-11	1	8
	60-110040-1	1	2
	95-110011-2	1	6
	95-110011-12	1	8
	60-110040-2	1	2
- 54	95-110014-251	1	
	95-110014-252	1	
- 55	95-110014-249	1	
	95-110014-250	1	
	MS21050L08K	6	
	95-110014-383	1	
- 56	95-110014-384	1	
	95-110014-381	1	
	95-110014-382	1	
- 57	MS21050L08K	6	
	95-110014-253	3	
	AN507B832R8	6	
- 58	95-110014-859	1	
	95-110014-860	1	
- 59	95-110014-861	1	
	95-110014-862	1	
- 60	95-110014-851	1	
	95-110014-852	1	
- 61	95-110014-853	1	
	95-110014-854	1	
	NAS680A08K	6	
- 62	60-110029-1	1	
	60-110029-2	1	
	60-110029-3	1	
	60-110029-4	1	
	60-110029-5	1	
- 63	60-110029-6	1	
	35-115246	1	
	35-115246-1	1	
	35-115246-2	1	
	35-115246-3	1	
	35-115246-4	1	
	35-115246-5	1	

BEECHCRAFT
DUKE B60
ILLUSTRATED PARTS CATALOG

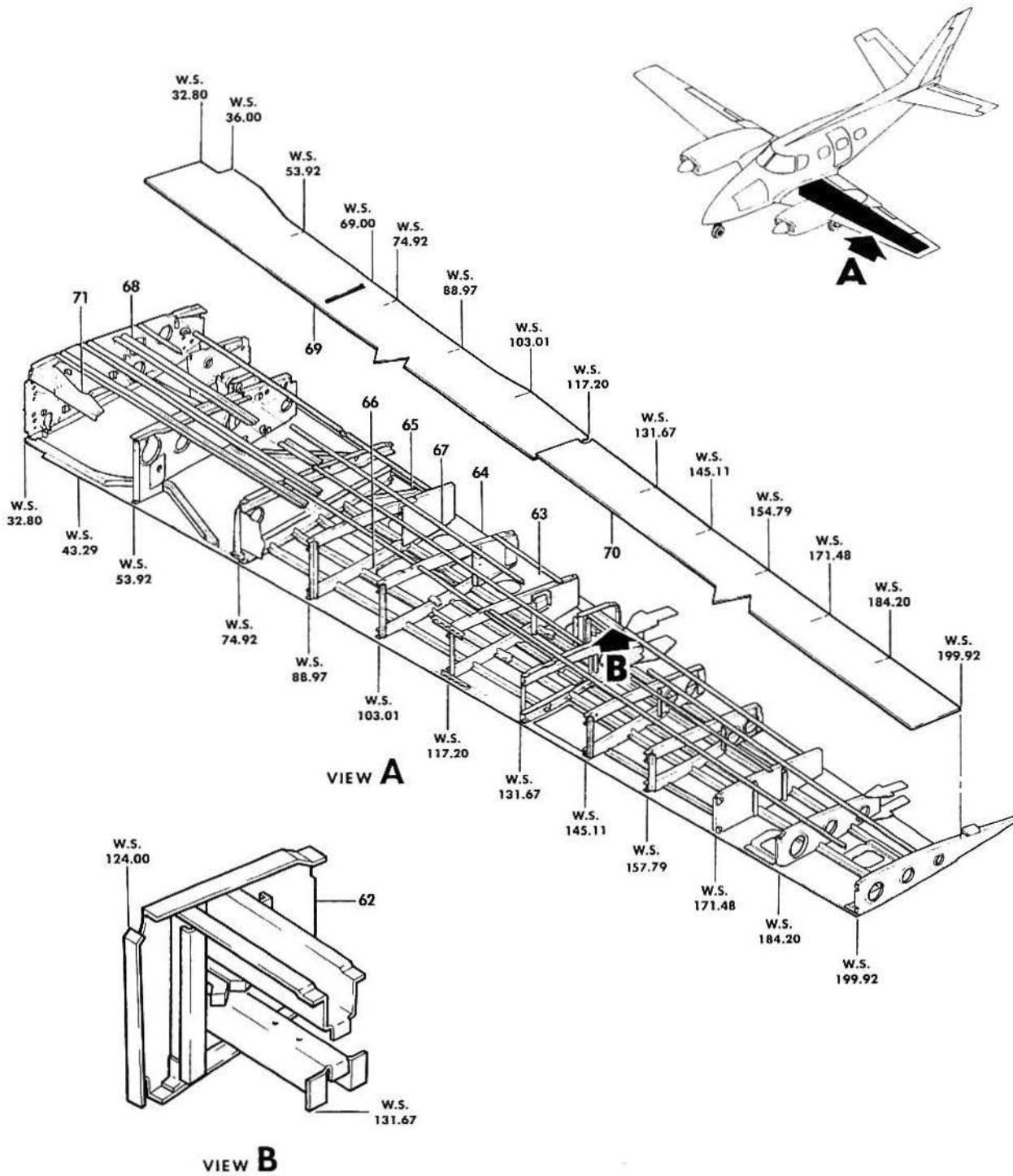

B60-36-5

B E E C H C R A F T
DUKE B60
I L L U S T R A T E D P A R T S C A T A L O G

GAMA/ATA CODE & INDEX NO.	PART NO.	1	2	3	4	5	6	7	DESCRIPTION	UNITS PER ASSY	USABLE ON CODE
10-10 - 62	95-110033-5	BRACKET ASSY,LH	1	
	95-110033-6	BRACKET ASSY,RH	1	
	95-110033-3	RIB,LH	1	
	95-110033-4	RIB,RH	1	
	35-115202-4	REINFORCEMENT,LH	1	
	35-115202-5	REINFORCEMENT,RH	1	
	35-115202-20	SUPPORT,LH	1	
	35-115202-21	SUPPORT,RH	1	
	35-115202-10	CLIP	1	
	35-115202-12	CLIP	1	
	35-115202-22	DOUBLER	1	
	35-115252-2	SUPPORT,LH	1	
	35-115252-3	SUPPORT,RH	1	
	35-115252-8	STOP	2	
	35-115252-10	REINFORCEMENT	1	
- 63	95-110014-655	DOUBLER ASSY,LH	1	
	95-110014-656	DOUBLER ASSY,RH	1	
	95-110014-335	DOUBLER,LH	1	
	95-110014-336	DOUBLER,RH	1	
	MS21047L08	NUTPLATE	4	
	35-115200-42	DOOR,ACCESS	2	9
	AN525-832	SCREW	4	
- 64	95-110014-1007	DOOR,ACCESS/LH ONLY/ /ATTACHING PARTS/	1	9
	AN525-832R7	SCREW	12	
- 65	95-110014-1003	DOUBLER ASSY,LH	1	
	95-110014-236	DOUBLER ASSY,RH	1	
	95-110014-1005	DOUBLER,LH	1	
	95-110014-238	DOUBLER,RH	1	
	NAS680A08K	NUTPLATE	20	
- 66	50-110074-602	DOUBLER ASSY,LH	1	
	50-110074-603	DOUBLER ASSY,RH	1	
	50-110074-3	DOUBLER,LH	1	
	50-110074-4	DOUBLER,RH	1	
	MS21059L08K	NUTPLATE	19	
	50-110074-5	DOOR,LH LINER ACCESS	1	
	50-110074-6	DOOR,RH LINER ACCESS	1	
	AN507-832-7	SCREW	19	
	95-110014-647	FORMER ASSY,LH	1	9
	95-110014-665	FORMER ASSY,LH	1	10
	95-110014-666	FORMER ASSY,RH	1	
- 67	95-110014-275	STRINGER,LH/STA 75 TO 131/	1	
	95-110014-276	STRINGER,RH/STA 75 TO 131/	1	
- 68	95-110014-931	FORMER,LH/STA 32.8 TO 75/	1	
	95-110014-932	FORMER,RH/STA 32.8 TO 75/	1	
	MS21047L3	NUTPLATE	2	
- 69	95-110014-921	SKIN,LH UPPER INBOARD	1	
	95-110014-480	SKIN,RH UPPER INBOARD	1	
- 70	95-110014-161	SKIN,UPPER OUTBD LH/W-O AUX FUEL TANKS/	1	1
	95-110014-817	SKIN,UPPER OUTBD LH/WITH AUX FUEL TANK/	1	1
	95-110014-1039	SKIN,UPPER OUTBD LH/WITH AUX FUEL TANK/	1	2
	95-110014-162	SKIN,UPPER OUTBD RH/W-O AUX FUEL TANKS/	1	1
	95-110014-818	SKIN,UPPER OUTBD RH/WITH AUX FUEL TANKS/	1	
	95-110014-163	DOUBLER,LH/WITHOUT AUX FUEL TANKS/	1	1
	95-110014-164	DOUBLER,RH/WITHOUT AUX FUEL TANKS/	1	1
	95-110014-165	DOUBLER,LH/WITHOUT AUX FUEL TANKS/	1	1
	95-110014-166	DOUBLER,RH/WITHOUT AUX FUEL TANKS/	1	1
	50-110025-44	DOOR,ACCESS/WITHOUT AUX FUEL TANKS/	1	1
	MS35489-17	GROMMET	1	
- 71	000-110230-1	GUSSET,LH/STA 32.805/	1	
	000-110230-2	GUSSET,RH/STA 32.805/	1	

BEECHCRAFT
DUKE B60
ILLUSTRATED PARTS CATALOG

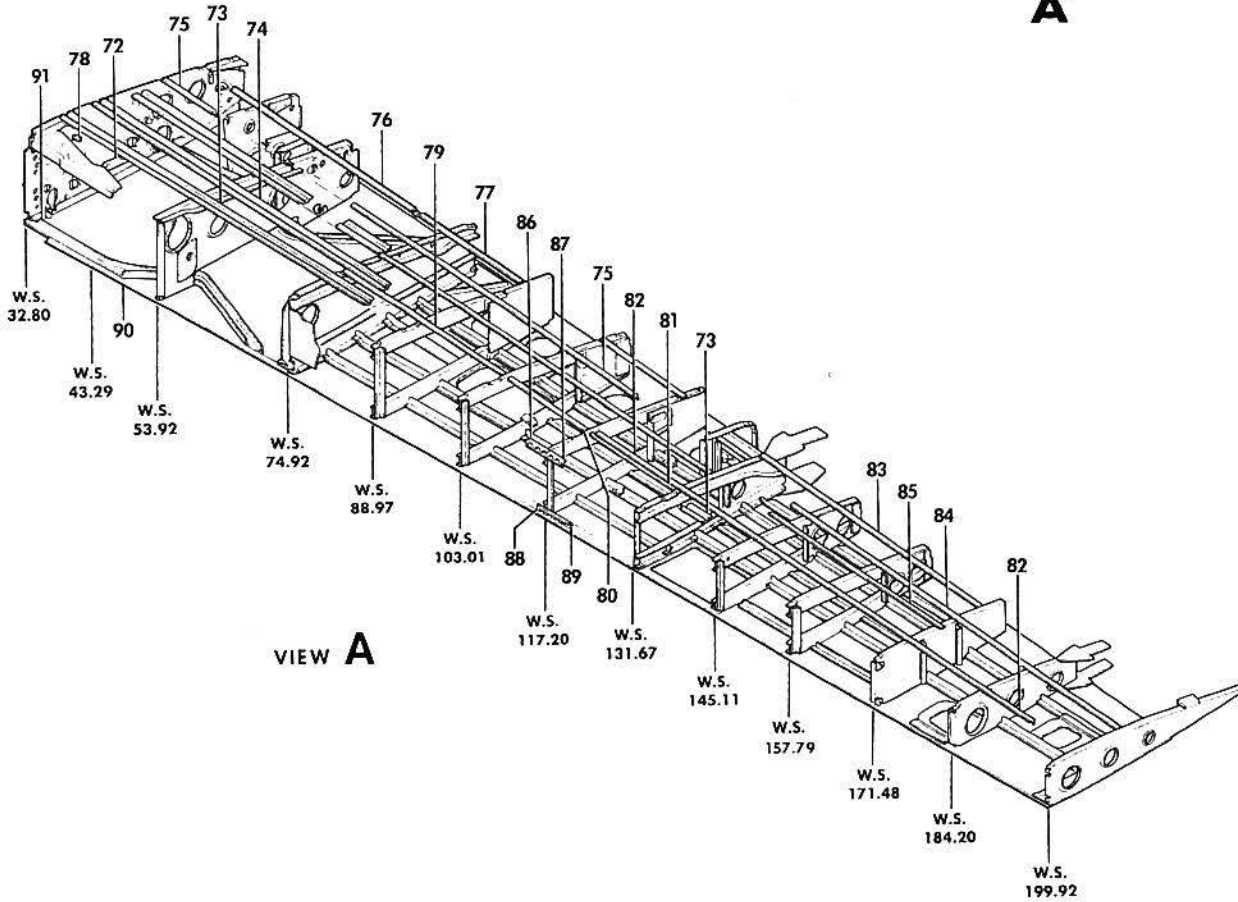
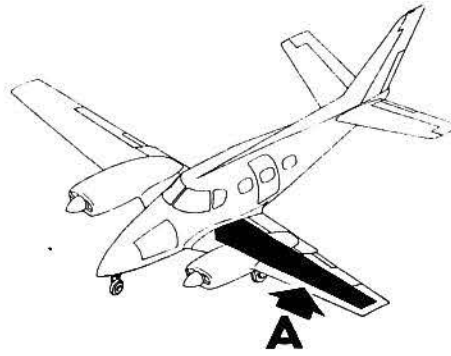

B60-36-6

B E E C H C R A F T
DUKE B60
I L L U S T R A T E D P A R T S C A T A L O G

GAMA/ATA CODE & INDEX NO.	PART NO.	1	2	3	4	5	6	7	DESCRIPTION	UNITS PER ASSY	USABLE ON CODE
10-10	95-110014-575	STIFFENER,LH & RH/STA 48.9/	1	
	95-110014-577	STIFFENER,LH & RH	1	
	95-110014-579	STIFFENER,LH & RH	1	
- 72	95-110014-581	STIFFENER,LH/STA 43.9/	1	
	95-110014-582	STIFFENER,RH/STA 43.9/	1	
	95-110014-527	DOUBLER,RH ONLY/STA 65/	1	
- 73	95-110014-139	STRINGER,LH/STA 32.8 TO 137.8/	1	
	95-110014-491	STRINGER,RH/STA 32.8 TO 137.8/	1	
- 74	95-110014-143	STRINGER,LH/STA 32.8 TO 117.2/	1	
	95-110014-493	STRINGER,RH/STA 32.8 TO 117.2/	1	
- 75	95-110014-517	STRINGER ASSY,LH.	1	
	95-110014-518	STRINGER ASSY,RH.	1	
- 76	95-110014-509	STRINGER,LH/STA 32.8 TO 69.26/	1	
	95-110014-510	STRINGER,RH/STA 32.8 TO 69.26/	1	
- 77	95-110014-507	STRINGER,LH/STA 69.26 TO 89/	1	
	95-110014-508	STRINGER,RH/STA 69.26 TO 89/	1	
	60-110022-35	CLIP,STRINGER LH.	1	11
	60-110022-49	CLIP,STRINGER LH.	1	12
	60-110023-35	CLIP,STRINGER RH.	1	11
	60-110023-51	CLIP,STRINGER RH.	1	12
- 78	35-115269	CLIP,STRINGER LH/STA 32.8/	1	
	35-115269-1	CLIP,STRINGER RH/STA 32.8/	1	
	35-115270	CLIP,STRINGER LH.	2	
	35-115270-1	CLIP,STRINGER RH.	2	
	35-115142-40	CLIP,STRINGER/LH ONLY/	2	
	35-115267	CLIP,STRINGER/LH ONLY/	2	
	108424-2	CLIP,STRINGER LH & RH	29	
- 79	95-110014-325	STRINGER,UPPER/STA 75 TO 103/	2	
- 80	95-110014-327	STRINGER,UPPER & LWR/STA 103 TO 117/	2	
- 81	95-110014-329	STRINGER,UPPER & LWR/STA 117 TO 131/	2	
	95-110014-905	STIFFENER,LH/STA 113 TO 117/	1	17
	95-110014-1085	STIFFENER,LH/STA 113 TO 117/	1	18
	95-110014-906	STIFFENER,RH/STA 113 TO 117/	1	17
- 82	95-110014-1086	STIFFENER,RH/STA 113 TO 117/	1	18
	95-110014-357	STRINGER,LH/STA 117 TO 199.9/	1	
	95-110014-358	STRINGER,RH/STA 117 TO 199.9/	1	
	95-110014-333	STIFFENER,UPPER & LOWER	2	
	95-110014-331	STIFFENER,UPPER & LOWER	2	
	95-110014-367	CLIP,STRINGER/STA 171.4/	2	
- 83	95-110014-913	STIFFENER,LH/STA 131.6 TO 171.4/	1	
	95-110014-914	STIFFENER,RH/STA 131.6 TO 171.4/	1	
- 84	95-110014-197	STRINGER,LH/STA 117 TO 199.9/	1	
	95-110014-198	STRINGER,RH/STA 117 TO 199.9/	1	
- 85	95-110014-903	STRINGER,LH/STA 131.6 TO 171.4/	1	
	95-110014-904	STRINGER,RH/STA 131.6 TO 171.4/	1	
	95-110014-1011	DOUBLER,LH.	1	
- 86	95-110014-295	HINGE,LH UPPER INBD/STA 32.8 TO 117.2/	1	
	95-110014-296	HINGE,RH UPPER INBD/STA 32.8 TO 117.2/	1	
- 87	95-110014-159	HINGE,LH UPPER OUTBD/STA 117.2 TO 199/	1	
	95-110014-160	HINGE,RH UPPER OUTBD/STA 117.2 TO 199/	1	
- 88	95-110014-321	HINGE,LH LOWER INBD/STA 32.8 TO 117.2/	1	
	95-110014-322	HINGE,RH LOWER INBD/STA 32.8 TO 117.2/	1	
- 89	95-110014-297	HINGE,LH LOWER OUTBD/STA 117.2 TO 199/	1	
	95-110014-298	HINGE,RH LOWER OUTBD/STA 117.2 TO 199/	1	
	45-115054-3	EXTENSION,FRAME LH.	1	13
	000-110185-1	EXTENSION,FRAME LH.	1	14
	45-115054-4	EXTENSION,FRAME RH.	1	13
	000-110185-2	EXTENSION,FRAME RH.	1	14
- 90	95-110014-537	SKIN,LOWER LH	1	
	95-110014-538	SKIN,LOWER RH	1	
	R 95-110014-649	SKIN ASSY,LOWER INBD LH	1	19
	R 95-110014-650	SKIN ASSY,LOWER INBD RH	1	19
- 91	R 35-115203	REINFORCEMENT,LH.	1	19
	R 35-115203-1	REINFORCEMENT,RH.	1	19
	R 35-115208	GUSSET,LH	1	19
	R 35-115208-1	GUSSET,RH	1	19

BEECHCRAFT
DUKE B60
ILLUSTRATED PARTS CATALOG

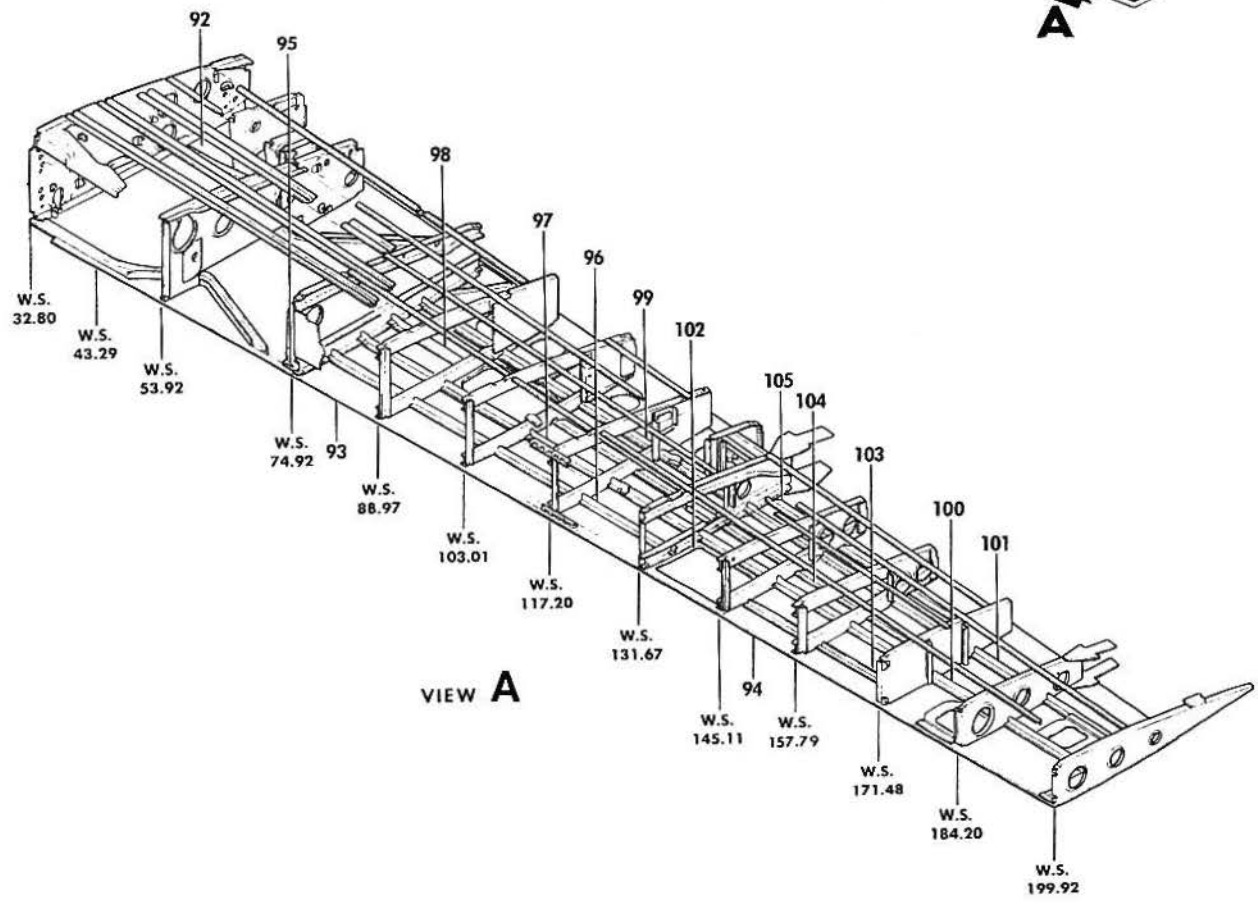
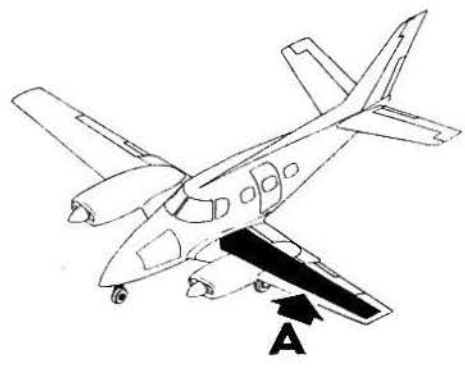

B60-36-7

B E E C H C R A F T
DUKE B60
I L L U S T R A T E D P A R T S C A T A L O G

GAMA/ATA CODE & INDEX NO.	PART NO.	DESCRIPTION							UNITS PER ASSY	USABLE ON CODE	
		1	2	3	4	5	6	7			
10-10	R 95-110014-733	SKIN ASSY,LOWER INBD LH	.	.	.	1	20
	R 95-110014-740	SKIN ASSY,LOWER INBD RH	.	.	.	1	20
- 92	95-110014-539	SKIN,LOWER LH	.	.	.	1	19
	95-110014-599	SKIN,LOWER RH	.	.	.	1	19
	R 102-100014-41	SKIN,LOWER LH	.	.	.	1	20
	95-110014-1077	SKIN,LOWER RH	.	.	.	1	20
	35-115200-30	STRINGER,LH	.	.	.	1	
	35-115200-31	STRINGER,RH	.	.	.	1	
	35-115205	REINFORCEMENT,LH.	.	.	.	1	
	35-115205-3	REINFORCEMENT,RH.	.	.	.	1	
	35-115207	GUSSET,LH	.	.	.	1	
	35-115207-1	GUSSET,RH	.	.	.	1	
	95-110014-353	COVER,LH & RH	.	.	.	1	19
	95-110014-597	CLIP,RH	.	.	.	1	
- 93	95-110014-205	SKIN,LOWER INBD LH.	.	.	.	1	
	95-110014-206	SKIN,LOWER INBD RH.	.	.	.	1	
- 94	95-110014-519	SKIN,LOWER OUTBD LH	.	.	.	1	1
	95-110014-1037	SKIN,LOWER OUTBD LH	.	.	.	1	2
	95-110014-520	SKIN,LOWER OUTBD RH	.	.	.	1	1
	95-110014-1038	SKIN,LOWER OUTBD RH	.	.	.	1	2
	60-300017-31	CONDUIT,STROBE LIGHT.	.	.	.	1	
	766-8	CLAMP	.	.	.	6	
	MS21047L08K	NUTPLATE.	.	.	.	18	
	MS21071L08K	NUTPLATE.	.	.	.	4	
	95-110014-449	DOUBLER,LOWER LH & RH	.	.	.	1	
	MS21042L08	NUTPLATE.	.	.	.	22	
- 95	95-110014-435	DOUBLER,LH/STA 74.9/.	.	.	.	1	
	95-110014-436	DOUBLER,RH/STA 74.9/.	.	.	.	1	
	95-110014-219	GUSSET,LH	.	.	.	1	
	95-110014-220	GUSSET,RH	.	.	.	1	
- 96	95-110014-229	STRINGER,LOWER LH/STA 74 TO 131.6/.	.	.	.	1	
	95-110014-230	STRINGER,LOWER RH/STA 74 TO 131.6/.	.	.	.	1	
- 97	95-110014-227	STRINGER,LOWER LH/STA 74 TO 119/.	.	.	.	1	
	95-110014-228	STRINGER,LOWER RH/STA 74 TO 119/.	.	.	.	1	
- 98	95-110014-225	STRINGER,LOWER LH/STA 74 TO 89/.	.	.	.	1	
	95-110014-226	STRINGER,LOWER RH/STA 74 TO 89/.	.	.	.	1	
- 99	95-110014-221	STRINGER,LOWER LH/STA 74 TO 119/.	.	.	.	1	
	95-110014-222	STRINGER,LOWER RH/STA 74 TO 119/.	.	.	.	1	
-100	95-110014-223	STRINGER,LOWER LH/STA 117 TO 199/.	.	.	.	1	
	95-110014-224	STRINGER,LOWER RH/STA 117 TO 199/.	.	.	.	1	
-101	95-110014-263	STRINGER,LOWER LH/STA 117 TO 199/.	.	.	.	1	
	95-110014-264	STRINGER,LOWER RH/STA 117 TO 199/.	.	.	.	1	
	95-110014-659	DOUBLER ASSY,LH	.	.	.	1	
	95-110014-660	DOUBLER ASSY,RH	.	.	.	1	
-102	95-110014-217	DOUBLER,LH.	.	.	.	1	
	95-110014-218	DOUBLER,RH	.	.	.	1	
	MS21059L08K	NUTPLATE.	.	.	.	4	
	MS21047L08	NUTPLATE.	.	.	.	10	
	MS21051L08	NUTPLATE.	.	.	.	4	
	95-110014-247	DOUBLER,LH.	.	.	.	1	
	95-110014-240	DOUBLER,RH.	.	.	.	1	
-103	000-110027-1	STIFFENER/STA 145 TO 171/.	.	.	.	1	
	MS21047L3	NUTPLATE.	.	.	.	6	
	95-110014-343	STIFFENER,LH.	.	.	.	1	
	95-110014-344	STIFFENER,RH.	.	.	.	1	
-104	95-110014-907	STIFFENER,LH/STA 103 TO 171/.	.	.	.	1	
	95-110014-908	STIFFENER,RH/STA 103 TO 171/.	.	.	.	1	
-105	95-110014-911	STIFFENER,LH/STA 131 TO 171/.	.	.	.	1	
	95-110014-912	STIFFENER,RH/STA 131 TO 171/.	.	.	.	1	

BEECHCRAFT
DUKE B60
ILLUSTRATED PARTS CATALOG

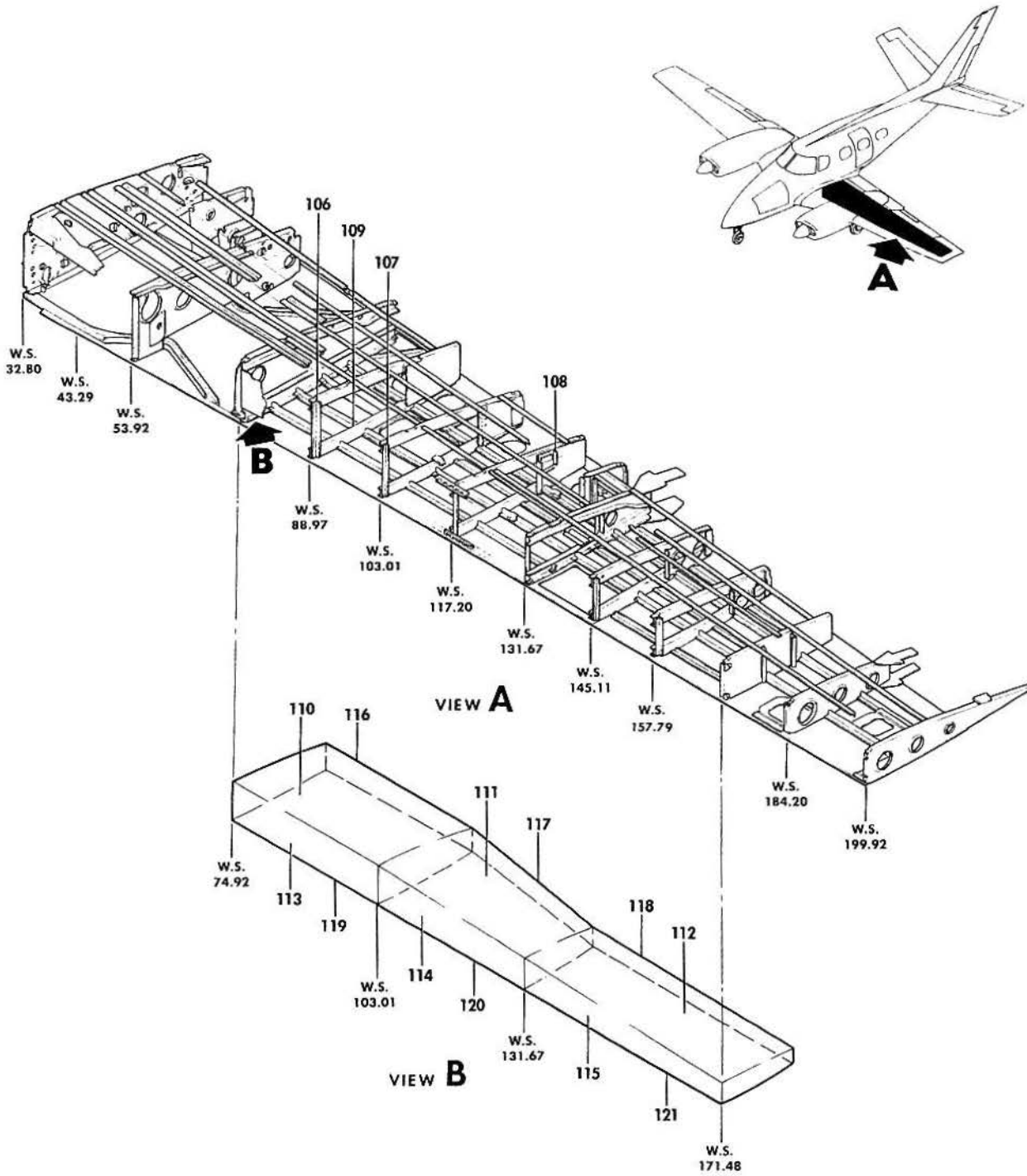

B60-36-8

B E E C H C R A F T
DUKE B60
I L L U S T R A T E D P A R T S C A T A L O G

GAMA/ATA CODE & INDEX NO.	PART NO.	DESCRIPTION	UNITS PER ASSY	USABLE ON CODE
		1 2 3 4 5 6 7		
10-10 -106	50-110002-122	• • ANGLE,LH/STA 89/	1	
	50-110002-123	• • ANGLE,RH/STA 89/	1	
-107	50-110002-132	• • ANGLE,LH/STA 103/	1	
	50-110002-133	• • ANGLE,RH/STA 103/	1	
	95-110014-433	• • FAIRLEAD/STA 117/	1	
	95-110014-287	• • ANGLE,LH/STA 117/	1	
	95-110014-288	• • ANGLE,RH/STA 117/	1	
-108	95-110014-347	• • DOUBLER,LH/STA 117/	1	
	95-110014-348	• • DOUBLER,RH/STA 117/	1	
	95-110014-285	• • ANGLE,LH/STA 117/	1	
	95-110014-286	• • ANGLE,RH/STA 117/	1	
	95-110014-657	• • FORMER ASSY,LH/WITHOUT AUX FUEL TANKS/	1	
	95-110014-773	• • FORMER ASSY,LH/WITH AUX FUEL TANKS/	1	
	95-110014-658	• • FORMER ASSY,RH/WITHOUT AUX FUEL TANKS/	1	
	95-110014-774	• • FORMER ASSY,RH/WITH AUX FUEL TANKS/	1	
-109	95-110014-185	• • FORMER,LH/STA 88.9/WITHOUT AUX FUEL TANK/	1	
	95-110014-1025	• • FORMER,LH/STA 88.9/WITH AUX FUEL TANK/	1	
	95-110014-186	• • FORMER,RH/STA 88.9/WITHOUT AUX FUEL TANK/	1	
	95-110014-1026	• • FORMER,RH/STA 88.9/WITH AUX FUEL TANK/	1	
	MS21047L3	• • NUTPLATE	3	
	95-110014-685	• • LINER ASSY,LH TOP	1	
	95-110014-686	• • LINER ASSY,RH TOP	1	
-110	95-110014-481	• • LINER,LH TOP/STA 74 TO 103/	1	
	95-110014-482	• • LINER,RH TOP/STA 74 TO 103/	1	
	50-110081	• • RETAINER	5	
	95-110014-679	• • LINER ASSY,LH TOP	1	
	95-110014-680	• • LINER ASSY,RH TOP	1	
-111	95-110014-473	• • LINER,LH TOP/STA 103 TO 131/	1	
	95-110014-474	• • LINER,RH TOP/STA 103 TO 131/	1	
	50-110081	• • RETAINER	5	
-112	95-110014-21	• • LINER,LH TOP/WITHOUT AUX FUEL TANKS/	1	
	95-110014-811	• • LINER,LH TOP/WITH AUX FUEL TANKS/	1	
	95-110014-22	• • LINER,RH TOP/WITHOUT AUX FUEL TANKS/	1	
	95-110014-812	• • LINER,RH TOP/WITH AUX FUEL TANKS/	1	
	50-110081	• • RETAINER	AR	
-113	95-110014-485	• • LINER,LH FRONT/STA 74 TO 103/	1	
	95-110014-486	• • LINER,RH FRONT/STA 74 TO 103/	1	
-114	95-110014-471	• • LINER,LH FRONT/STA 103 TO 131/	1	
	95-110014-472	• • LINER,RH FRONT/STA 103 TO 131/	1	
-115	95-110014-17	• • LINER,LH FRONT/WITHOUT AUX FUEL TANKS/	1	
	95-110014-807	• • LINER,LH FRONT/WITH AUX FUEL TANKS/	1	
	95-110014-18	• • LINER,RH FRONT/WITHOUT AUX FUEL TANKS/	1	
	95-110014-808	• • LINER,RH FRONT/WITH AUX FUEL TANKS/	1	
	95-110014-809	• • DOUBLER/WITH AUX FUEL TANKS/	1	
-116	95-110014-9	• • LINER,LH AFT/STA 74 TO 103/	1	
	95-110014-10	• • LINER,RH AFT/STA 74 TO 103/	1	
-117	95-110014-13	• • LINER,LH AFT/STA 103 TO 131/	1	
	95-110014-14	• • LINER,RH AFT/STA 103 TO 131/	1	
-118	95-110014-15	• • LINER,LH AFT/STA 131 TO 171/	1	
	95-110014-16	• • LINER,RH AFT/STA 131 TO 171/	1	
-119	95-110014-483	• • LINER,LH BOTTOM/STA 74 TO 103/	1	
	95-110014-484	• • LINER,RH BOTTOM/STA 74 TO 103/	1	
-120	95-110014-23	• • LINER,LH BOTTOM/STA 103 TO 131/	1	
	95-110014-24	• • LINER,RH BOTTOM/STA 103 TO 131/	1	
-121	95-110014-19	• • LINER,LH BOTTOM/STA 131 TO 171/	1	
	95-110014-20	• • LINER,RH BOTTOM/STA 131 TO 171/	1	
	108424-2	• • CLIP,STRINGER & LINER	40	

BEECHCRAFT
DUKE B60
ILLUSTRATED PARTS CATALOG

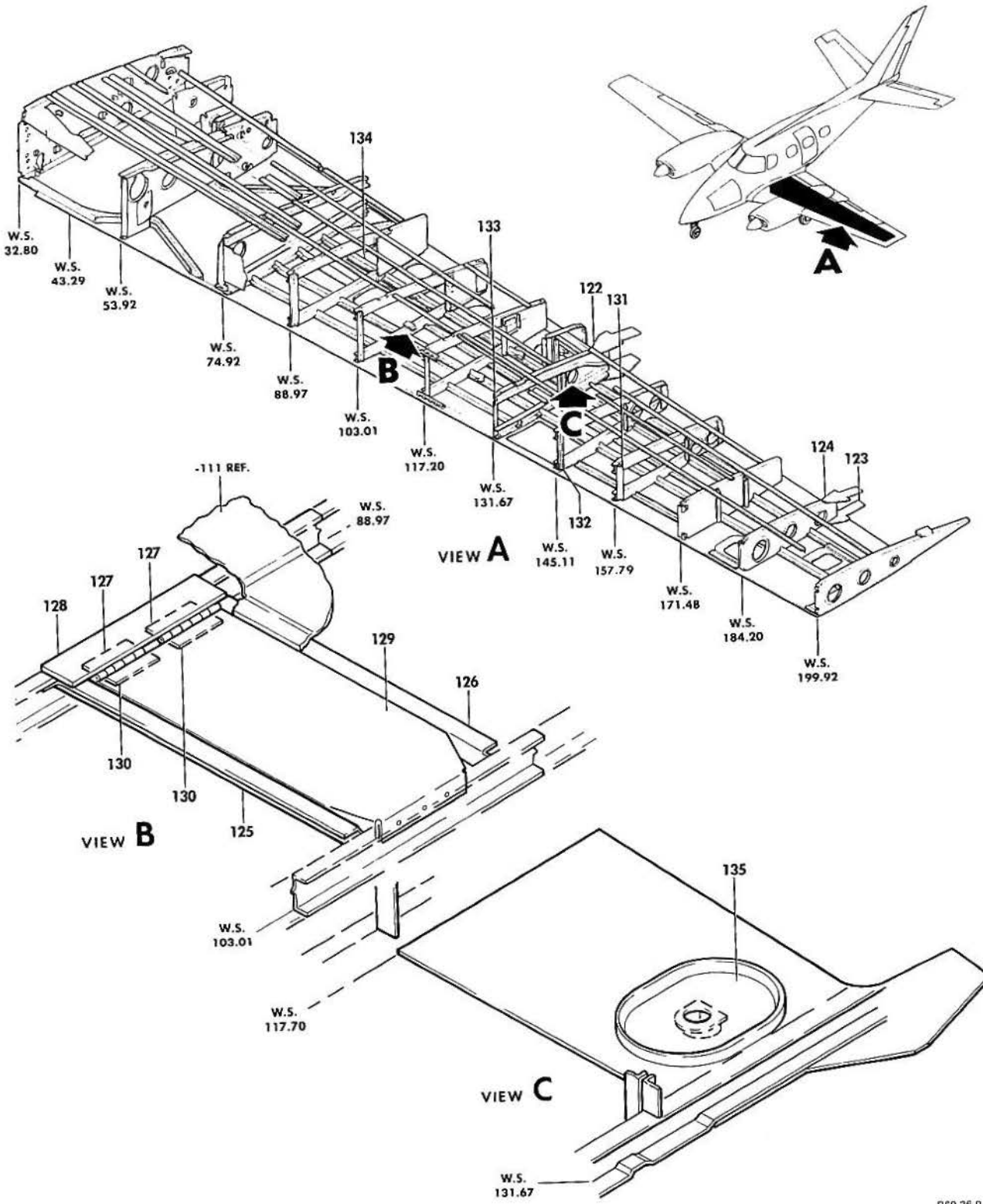

B60-36-9

B E E C H C R A F T
DUKE B60
I L L U S T R A T E D P A R T S C A T A L O G

GAMA/ATA CODE & INDEX NO.	PART NO.	DESCRIPTION							UNITS PER ASSY	USABLE ON CODE	
		1	2	3	4	5	6	7			
10-10 -122	95-110014-845	. .	GUSSET,LH	UPPER/STA	131.6/	1			
	95-110014-846	. .	GUSSET,RH	UPPER/STA	131.6/	1			
-123	95-110014-847	. .	GUSSET,LH	LOWER/STA	184.2/	1			
	95-110014-848	. .	GUSSET,RH	LOWER/STA	184.2/	1			
-124	95-110014-849	. .	GUSSET,LH	UPPER/STA	184.2/	1			
	95-110014-850	. .	GUSSET,RH	UPPER/STA	184.2/	1			
	95-521000-45	. .	BRACKET,LH.	1			
	95-521000-46	. .	BRACKET,RH.	1			
	35-115276	. .	CLIP,RH	STRINGER/STA	54/	3			
	95-110014-189	. .	ANGLE,LH	LINER ATTACH/STA	89/	1			
	95-110014-190	. .	ANGLE,RH	LINER ATTACH/STA	89/	1			
	35-115142-26	. .	ANGLE,HINGE	SPLICE UPPER & LOWER.	2			
	50727	. .	BUTTON,PLUG	1			
	MS35489-6	. .	GROMMET/SUPERSEDES	AN931-4-7/	15			
-125	50-110002-136	. .	ANGLE,LH.	1			
	50-110002-137	. .	ANGLE,RH.	1			
-126	50-110002-138	. .	ANGLE,LH.	1			
	50-110002-139	. .	ANGLE,RH.	1			
-127	50-110002-140	. .	HINGE,HALF.	2			
-128	50-110002-150	. .	DOUBLER,LH.	1			
	50-110002-151	. .	DOUBLER,RH.	1			
	95-110014-653	. .	DOOR ASSY,LH	LINER ACCESS	1			
	95-110014-654	. .	DOOR ASSY,RH	LINER ACCESS	1			
			/ATTACHING PARTS/								
	AN3-8A	. .	BOLT.	3			
	102361-00228	. .	PIN,HINGE	2			
			-----*								
-129	50-110002-134	. .	DOOR,LH	1			
	50-110002-135	. .	DOOR,RH	1			
-130	50-110002-140	. .	HINGE,ACCESS	DOOR HALF.	2			
	95-110014-337	. .	CLIP,LH	1			
	95-110014-345	. .	CLIP.	1			
-131	95-110014-65	. .	ANGLE,LH/STA	157/	1			
	95-110014-66	. .	ANGLE,RH/STA	157/	1			
-132	95-110014-83	. .	ANGLE,LH/STA	145/	1			
	95-110014-84	. .	ANGLE,RH/STA	145/	1			
-133	95-110014-93	. .	ANGLE,LH/STA	131/	1			
	95-110014-94	. .	ANGLE,RH/STA	131/	1			
	35-115269	. .	CLIP,STRINGER	1			
	95-110014-937	. .	CONDUIT,LH & RH	1			
	95-110014-1017	. .	CONDUIT,LH & RH	1	6		
	95-110014-1035	. .	CONDUIT,LH & RH	1	15		
	115005-1	. .	GROMMET	5	16		
	766-6	. .	CLAMP	4			
			/ATTACHING PARTS/								
	MS27039-0804	. .	SCREW	1			
	AN960-8	. .	WASHER.	1			
	130909N28	. .	NUT	1			
			-----*								
	50-920077	. .	FLANGE ASSY,FUEL	VENT	1			
-134	95-110014-1001	. .	DOOR,LH	ACCESS/STA 85/WITH	AUX FUEL TANKS/	1			
	60-110033-1	. .	COVER ASSY,FLAP	LIMIT SWITCH LH	1			
	60-110033-2	. .	COVER ASSY,FLAP	LIMIT SWITCH RH	1			
-135	95-110014-339	. .	DOOR ASSY,LH & RH	1			
			/ATTACHING PARTS/								
	AN525-832	. .	SCREW	6			
			-----*								
	95-110014-341	. .	DOOR,ACCESS	1			
	95-110014-355	. .	COVER	1			
	50-110011-1	. .	DOOR ASSY,WING	FUEL ACCESS LH	1			
	50-110011-2	. .	DOOR ASSY,WING	FUEL ACCESS RH	1			

BEECHCRAFT
DUKE B60
ILLUSTRATED PARTS CATALOG

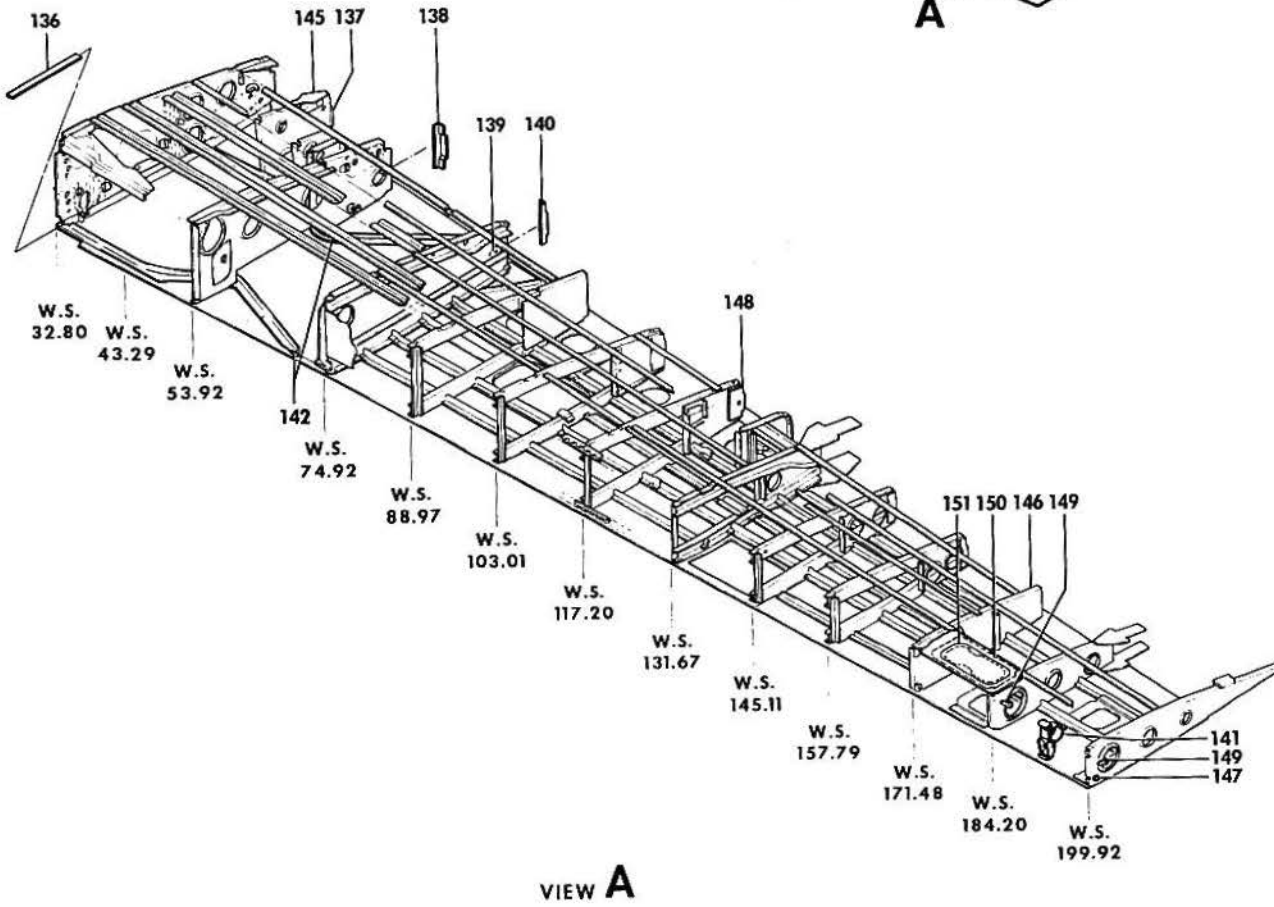
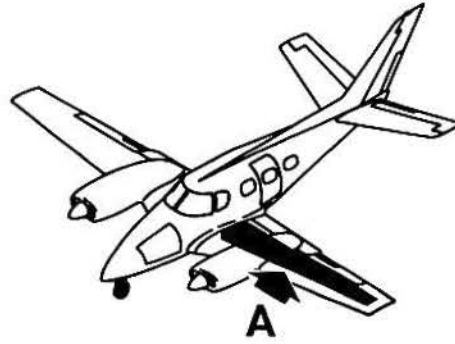

B60-38-13

B E E C H C R A F T
DUKE B60
I L L U S T R A T E D P A R T S C A T A L O G

GAMA/ATA CODE & INDEX NO.	PART NO.	1 2 3 4 5 6 7	DESCRIPTION	UNITS PER ASSY	USABLE ON CODE
10-10 -136	60-110038-3		STRAP,RIB LH/STA 32.805/.	1	
	60-110038-4		STRAP,RIB RH/STA 32.805/.	1	
			/ATTACHING PARTS/		
	MS27039-0810		SCREW	8	
	AN960-8		WASHER	8	
	130909N28		NUT	8	

-137	95-110030-11		ANGLE,RIB LH/STA 43.299/.	1	
	95-110039-3		ANGLE,RIB RH/STA 43.299/.	1	
-138	95-110027-3		ANGLE,RIB RH.	1	
-139 R	95-110023-27		FAIRLEAD,RIB LH/STA 74.924/	1	21
-140	95-110023-23		ANGLE,RIB LH/STA 74.924/.	1	
	95-110023-24		ANGLE,RIB RH/STA 74.924/.	1	
-141	60-921029-1		BRACKET INSTL,LH/WITHOUT AUX FUEL TANKS/.	1	
	60-921029-2		BRACKET INSTL,RH/WITHOUT AUX FUEL TANKS/.	1	
-142	35-115301-44		SEAL	2	
-143			DELETED,		
-144			DELETED,		
-145	95-110014-277		GUSSET,LH	1	
	95-110014-505		GUSSET,RH	1	
-146	95-110014-475		RIB,LH/WITHOUT AUX FUEL TANKS/.	1	
	95-110014-803		RIB,LH/WITH AUX FUEL TANKS/	1	
	95-110014-476		RIB,RH/WITHOUT AUX FUEL TANKS/.	1	
	95-110014-804		RIB,RH/WITH AUX FUEL TANKS/	1	
-147	MS35489-1		GROMMET/WITH AUX FUEL TANKS/.	1	2
-148	95-110014-299		ANGLE,LH.	1	
	95-110014-300		ANGLE,RH.	1	
-149	LHMS-S10		MOUNT,LIGHTENING HOLE/STA 199.92/	2	7
			/ATTACHING PARTS/		
	MS35207-264		SCREW	1	
	AN960-10L		WASHER	1	
	MS21042L3		NUT	1	
	MS3367-1-9		STRAP,TIE	1	

-150	50-110093-4		DOUBLER ASSY,FLUX DETECTOR ACCESS	1	
-151	50-110093-2		DOOR,FLUX DETECTOR ACCESS	1	
			/ATTACHING PARTS/		
	MS24693BB50		SCREWS.	6	

CODES OF EFFECTIVITY

1	P-247 THRU P-347	2	P-348,
	P-349 THRU P-364		P-365 AND AFTER
3	P-247 THRU P-275	4	P-247 THRU P-344
5	P-345 AND AFTER	6	P-247 THRU P-309
7	P-310 AND AFTER	8	P-310 THRU P-347
			P-349 THRU P-364
9	P-247 THRU P-322	10	P-323 AND AFTER
11	P-247 THRU P-249	12	P-250 AND AFTER
13	P-247 THRU P-268	14	P-269 AND AFTER
15	P-310 THRU P-366	16	P-367 AND AFTER
17	P-247 THRU P-486	18	P-487 AND AFTER
19	P-247 THRU P-434	20	P-435 AND AFTER
21	P-247 THRU P-541		

BEECHCRAFT
DUKE B60
ILLUSTRATED PARTS CATALOG

57-10-20
WING FRONT SPAR

BEECHCRAFT
DUKE B60
ILLUSTRATED PARTS CATALOG

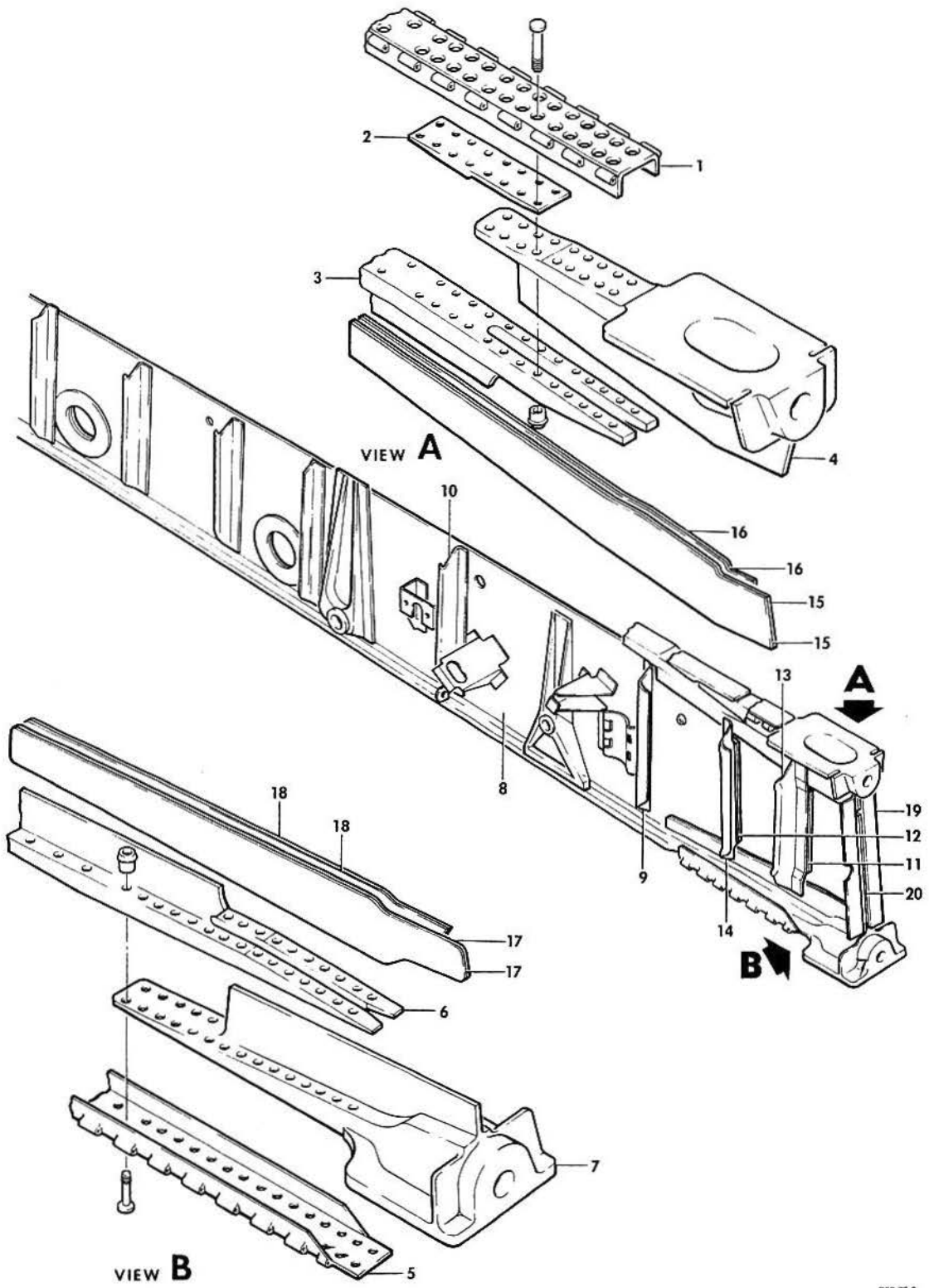

B60-35-2

FIGURE 10-20. WING FRONT SPAR
/SHEET 1 OF 2 SHEETS/

B E E C H C R A F T
DUKE B60
I L L U S T R A T E D P A R T S C A T A L O G

GAMA/ATA CODE & INDEX NO.	PART NO.	DESCRIPTION							UNITS PER ASSY	USABLE ON CODE	
		1	2	3	4	5	6	7			
10-20	000-110011-7	SPAR	ASSY,	FRONT	LH	WING	.	.	.	1	
	000-110011-8	SPAR	ASSY,	FRONT	RH	WING	.	.	.	1	
	000-110011-33	SPAR	ASSY,	FRONT	LH	WING/202	GAL.	SYSTEM/	.	1	4
	000-110011-34	SPAR	ASSY,	FRONT	RH	WING/202	GAL.	SYSTEM/	.	1	4
	000-110011-25	SPAR	ASSY,	FRONT	LH	WING/232	GAL.	SYSTEM/	.	1	4
	000-110011-26	SPAR	ASSY,	FRONT	RH	WING/232	GAL.	SYSTEM/	.	1	4
	000-110011-3	SPAR	ASSY,	FRONT	LH					1	
	000-110011-4	SPAR	ASSY,	FRONT	RH					1	
	000-110011-1	SPAR	ASSY,	LH						1	
	000-110011-2	SPAR	ASSY,	RH						1	
	000-110013-1	CAP	ASSY,	FRONT	SPAR	UPPER	LH			1	
	000-110013-2	CAP	ASSY,	FRONT	SPAR	UPPER	RH			1	
- 1	000-110013-9	HINGE	CAP,	LH						1	
	000-110013-10	HINGE	CAP,	RH						1	
- 2 R	000-110013-7	FILLER								1	7
- 3	000-110013-11	TEE,	LH							1	
	000-110013-12	TEE,	RH							1	
- 4 R	000-110250-1	FITTING,	LH							1	
R	000-110250-2	FITTING,	RH							1	
	NAS1486-14	BOLT,	LOCK							4	
	NAS1486-15	BOLT,	LOCK							2	
	NAS1486-16	BOLT,	LOCK							2	
	NAS1486-17	BOLT,	LOCK							4	
	NAS1486-18	BOLT,	LOCK							6	
	NAS1486-19	BOLT,	LOCK							6	
	NAS1486-20	BOLT,	LOCK							2	
	NAS1080-6	COLLAR								26	
	000-110013-3	CAP	ASSY,	FRONT	SPAR	LOWER	LH			1	
	000-110013-4	CAP	ASSY,	FRONT	SPAR	LOWER	RH			1	
- 5	000-110013-15	HINGE	CAP,	LH						1	
	000-110013-16	HINGE	CAP,	RH						1	
	MS21051-3	NUTPLATE								4	
- 6	000-110013-13	TEE,	LH							1	
	000-110013-14	TEE,	RH							1	
	35-110065-1	FITTING,	LH							1	1
	35-110065-2	FITTING,	RH							1	1
- 7	000-110088-1	FITTING,	LH							1	2
	000-110088-2	FITTING,	RH							1	2
	NAS1486-11	BOLT,	LOCK							2	
	NAS1486-12	BOLT,	LOCK							2	
	NAS1486-13	BOLT,	LOCK							2	
	NAS1486-14	BOLT,	LOCK							2	
	NAS1486-15	BOLT,	LOCK							6	
	NAS1486-16	BOLT,	LOCK							8	
	NAS1486-17	BOLT,	LOCK							8	
	NAS1080-6	COLLAR								30	
	000-110014-1	WEB	ASSY,	FRONT	SPAR	LH	INBOARD			1	
	000-110014-2	WEB	ASSY,	FRONT	SPAR	RH	INBOARD			1	
- 8	000-110014-5	WEB,	LH							1	
	000-110014-6	WEB,	RH							1	
- 9	000-110014-7	STIFFENER								1	
- 10	000-110014-9	STIFFENER								1	
- 11	000-110011-9	SPACER								1	
- 12	000-110011-11	SPACER								1	
- 13	000-110010-39	STIFFENER,	LH							1	
	000-110010-40	STIFFENER,	RH							1	
- 14	000-110010-41	STIFFENER								1	
- 15	000-110095-1	PLATE,	TIE	UPPER						2	
- 16	000-110095-3	PLATE,	TIE	UPPER						2	
- 17	000-110024-1	PLATE,	TIE	LOWER						2	
- 18	000-110024-3	PLATE,	TIE	LOWER						2	
- 19	000-110010-35	ANGLE,	LH							1	
	000-110010-36	ANGLE,	RH							1	
- 20	000-110010-37	SPACER								1	

BEECHCRAFT
DUKE B60
ILLUSTRATED PARTS CATALOG

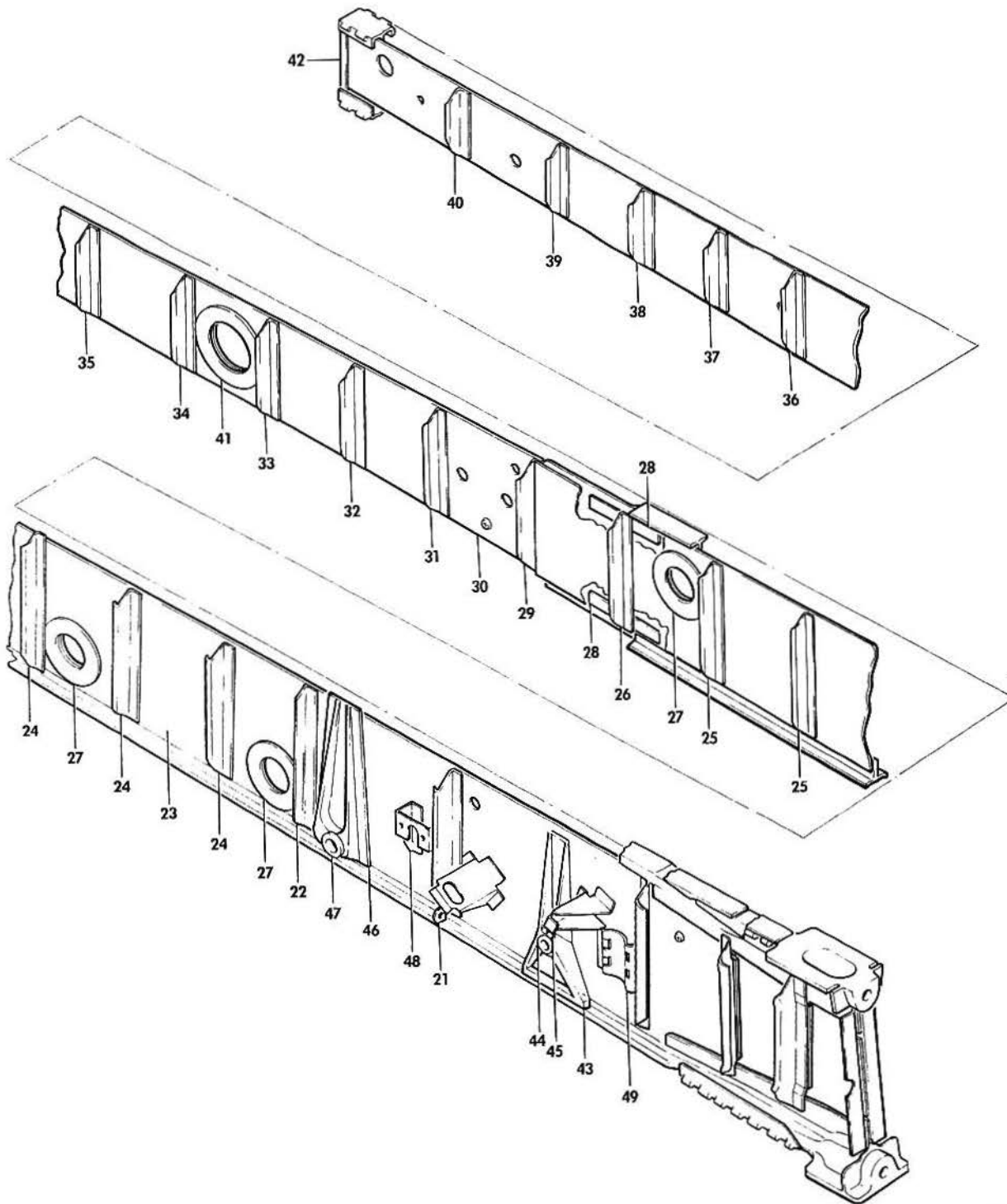

B60-25-3

B E E C H C R A F T
DUKE B60
I L L U S T R A T E D P A R T S C A T A L O G

GAMA/ATA CODE & INDEX NO.	PART NO.	DESCRIPTION							UNITS PER ASSY	USABLE ON CODE
		1	2	3	4	5	6	7		
10-20	MS35489-6	2	
	HL18PB6-5	4	
	NAS679A3	4	
- 21	000-110010-55	1	
- 22	000-110010-43	1	5
	000-110190-1	1	6
	000-110010-3	1	
	000-110010-4	1	
- 23	000-110010-5	1	
- 24	000-110010-7	3	
- 25	000-110010-9	2	
- 26	000-110010-11	1	
- 27	000-110010-51	3	
	MS35489-6	1	
- 28	000-110010-53	2	
	MS21061L4	2	
	000-110011-31	1	4
- 29	000-110010-45	1	
	000-110011-13	1	
	000-110011-14	1	
	000-110010-57	1	4
	000-110010-58	1	4
- 30	000-110010-15	1	
- 31	000-110010-17	1	
- 32	000-110010-19	1	
- 33	000-110010-21	1	
- 34	000-110010-23	1	
- 35	000-110010-25	1	
- 36	000-110011-15	1	
- 37	000-110010-27	1	
- 38	000-110011-17	1	
- 39	000-110010-29	1	
- 40	000-110011-19	1	
- 41	000-110010-47	1	
	D08431-1	1	3
- 42	000-110028-1	1	
	000-110028-2	1	
	MS21047L08	2	
	NAS1080-6	68	
	NAS1466-6	7	
	NAS1466-4	2	
	NAS1466-10	6	
	NAS1466-12	48	
	NAS1466-13	5	
	000-110022-1	1	
- 43	000-110022-3	1	
- 44	35-115184	1	
- 45	MS15001-3	1	
	000-110023-1	1	
- 46	000-110023-3	1	
- 47	35-115215	1	
	000-361010-1	1	
	000-361011-1	1	
	000-361011-2	1	
- 48	000-920010-1	1	
- 49	000-920011-1	1	

C O D E S O F E F F E C T I V I T Y

1	P-247 THRU P-266	2	P-267 AND AFTER
3	P-247 THRU P-263	4	P-348, P-365 AND AFTER
5	P-247 THRU P-321	6	P-322 AND AFTER
7	P-247 THRU P-585		

BEECHCRAFT
DUKE B60
ILLUSTRATED PARTS CATALOG

57-10-30
WING REAR SPAR

BEECHCRAFT
DUKE B60
ILLUSTRATED PARTS CATALOG

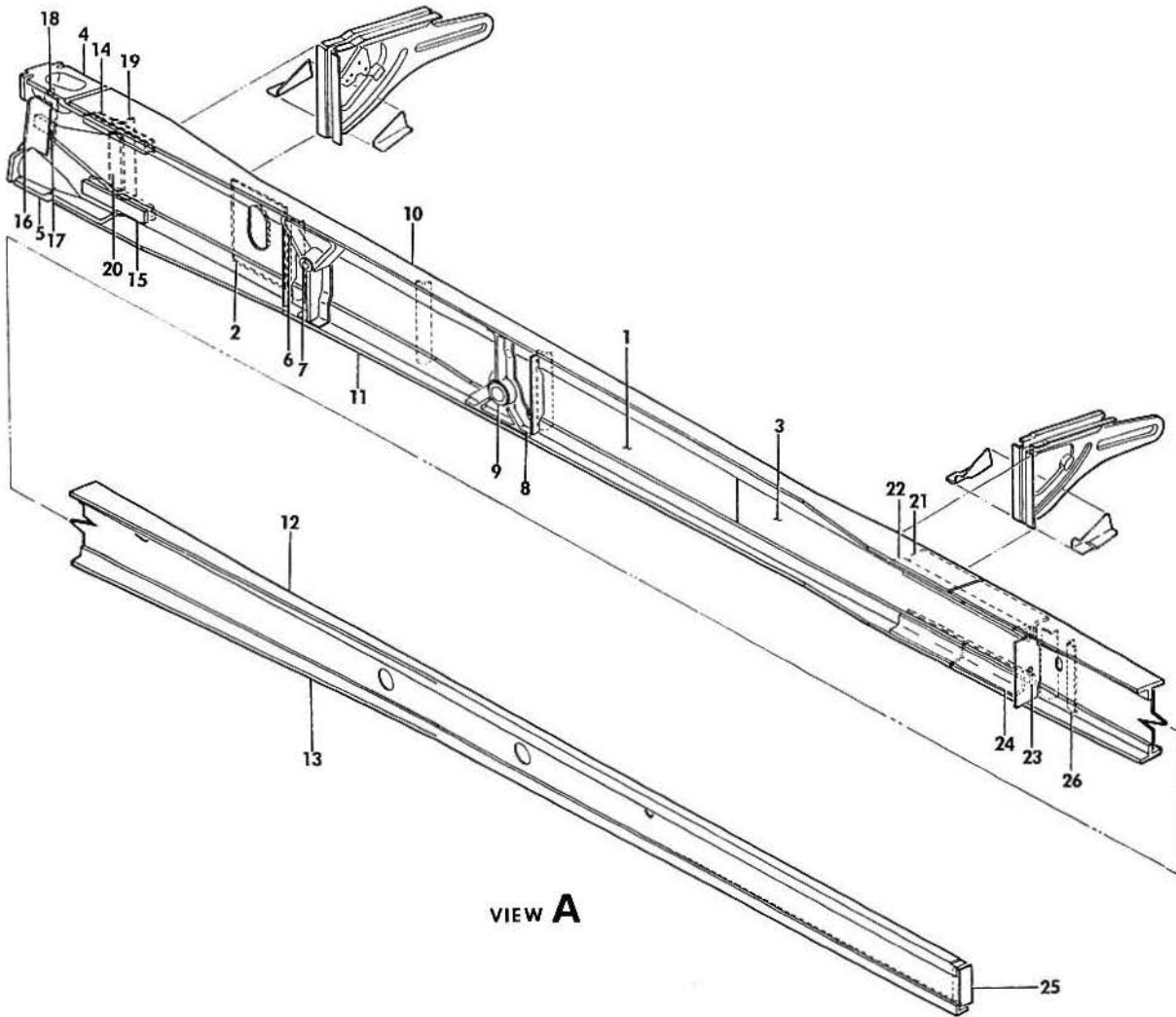
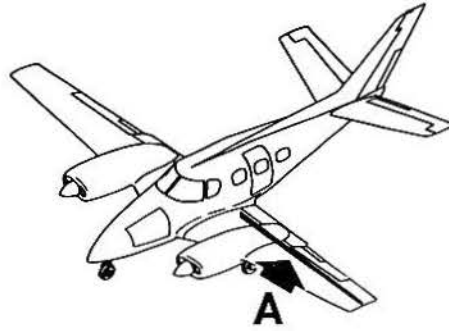

B60-37-2

B E E C H C R A F T
DUKE B60
I L L U S T R A T E D P A R T S C A T A L O G

GAMA/ATA CODE & INDEX NO.	PART NO.	DESCRIPTION	UNITS PER ASSY	USABLE ON CODE
		1 2 3 4 5 6 7		
10-30	95-110022-611	SPAR ASSEMBLY,REAR LH	1	
	95-110022-614	SPAR ASSEMBLY,REAR RH	1	
	95-110022-605	. WEB ASSY,LH REAR SPAR INBOARD	1	
	95-110022-606	. WEB ASSY,RH REAR SPAR INBOARD	1	
- 1	95-110022-11	. . WEB,LH INBOARD.	1	
	95-110022-12	. . WEB,RH INBOARD.	1	
- 2	95-110022-65	. . REINFORCEMENT,LH.	1	
	95-110022-66	. . REINFORCEMENT,RH.	1	
- 3	95-110022-13	. WEB,LH REAR SPAR OUTBOARD	1	
	95-110022-14	. WEB,RH REAR SPAR OUTBOARD	1	
- 4	95-110016-1	. FITTING,LH SPAR UPPER	1	
	95-110016-2	. FITTING,RH SPAR UPPER	1	
- 5	95-110017-1	. FITTING,LH SPAR LOWER	1	
	95-110017-2	. FITTING,RH SPAR LOWER	1	
	95-110019-1	. ADAPTER ASSY,LH DRAG LEG HINGE POINT AFT.	1	
	95-110019-2	. ADAPTER ASSY,RH DRAG LEG HINGE POINT AFT.	1	
- 6	95-110019-3	. . ADAPTER,LH.	1	
	95-110019-4	. . ADAPTER,RH.	1	
- 7	35-115062	. . BUSHING	1	
	MS15001-4	. . FITTING,LUBE.	1	
	95-110020-1	. ADAPTER ASSY,LH MAIN GEAR HINGE POINT AFT	1	1
	95-110020-5	. ADAPTER ASSY,LH MAIN GEAR HINGE POINT AFT	1	2
	95-110020-2	. ADAPTER ASSY,RH MAIN GEAR HINGE POINT AFT	1	1
	95-110020-6	. ADAPTER ASSY,RH MAIN GEAR HINGE POINT AFT	1	2
- 8	95-110020-3	. . ADAPTER,LH.	1	1
	95-110020-7	. . ADAPTER,LH.	1	2
	95-110020-4	. . ADAPTER,RH.	1	1
	95-110020-8	. . ADAPTER,RH.	1	2
- 9	45-115064	. . BUSHING	1	
- 10	95-110022-3	. CAP,LH UPPER INBD	1	
	95-110022-4	. CAP,RH UPPER INBD	1	
- 11	95-110022-5	. CAP,LH LOWER INBD	1	
	95-110022-6	. CAP,RH LOWER INBD	1	
- 12	95-110022-7	. CAP,LH UPPER OUTBD.	1	
	95-110022-8	. CAP,RH UPPER OUTBD.	1	
- 13	95-110022-9	. CAP,LH LOWER OUTBD.	1	
	95-110022-10	. CAP,RH LOWER OUTBD.	1	
- 14	95-110022-73	. STRAP,UPPER	2	
- 15	95-110022-17	. STRAP,LOWER	2	
- 16	95-110022-19	. ANGLE, FORWARD	1	
- 17	95-110022-21	. SPACER.	1	
- 18	95-110022-23	. ANGLE, AFT	1	
- 19	95-110022-25	. ANGLE, LH.	1	
	95-110022-26	. ANGLE, RH.	1	
- 20	95-110022-27	. SPACER.	1	
- 21	95-110022-29	. ANGLE, UPPER AFT	1	
- 22	95-110022-31	. ANGLE, UPPER FWD	1	
- 23	95-110022-33	. ANGLE, LOWER AFT	1	
- 24	95-110022-35	. ANGLE, LOWER FWD	1	
- 25	95-110022-67	. ANGLE	1	
- 26	95-110022-81	. ANGLE, LH ONLY	1	
	SLS100T8-9	. STUMP,RIVIT	20	
	ALPPHT8-12	. BOLT,HUCK	2	
	ALPPHT8-11	. BOLT,HUCK	10	
	LC-C8	. COLLAR.	32	
	ALPPHT6-6	. BOLT,HUCK	10	
	LC-C6	. COLLAR.	10	

BEECHCRAFT
DUKE B60
ILLUSTRATED PARTS CATALOG

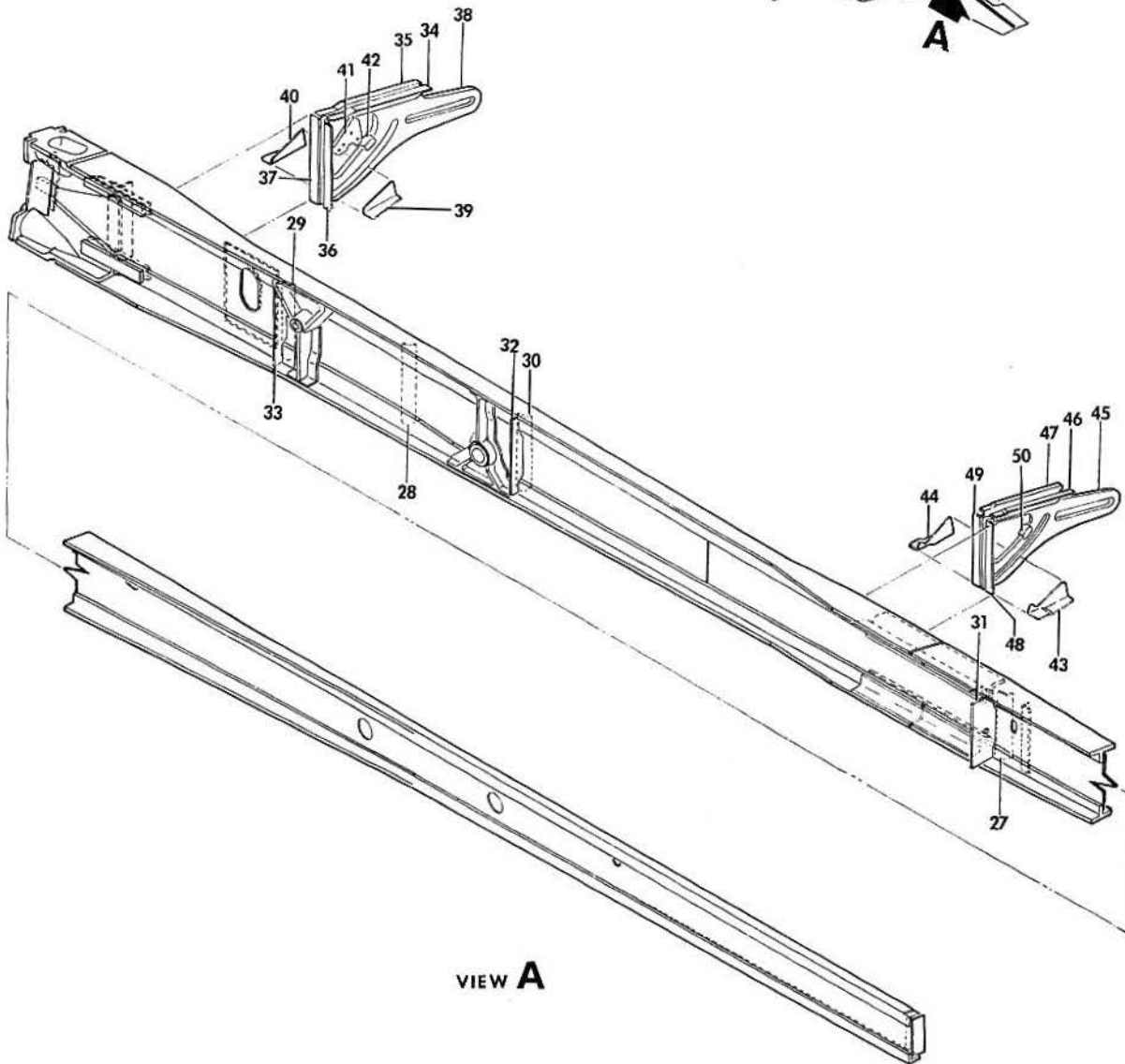
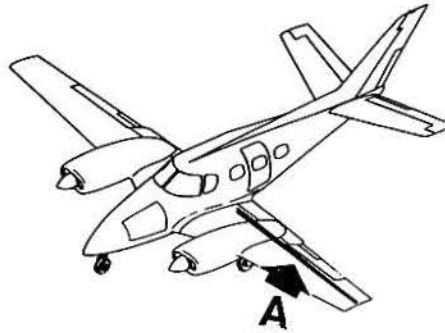

B60.37-3

B E E C H C R A F T
DUKE B60
I L L U S T R A T E D P A R T S C A T A L O G

GAMA/ATA CODE & INDEX NO.	PART NO.	DESCRIPTION							UNITS PER ASSY	USABLE ON CODE
		1	2	3	4	5	6	7		
10-30 - 27	95-110014-123	1	
	95-110014-124	1	
- 28	95-110014-125	1	
	95-110014-126	1	
- 29	95-110014-131	1	
	95-110014-132	1	
- 30	95-110014-155	1	
	95-110014-156	1	
- 31	95-110014-299	1	
	95-110014-300	1	
- 32	95-110023-23	1	
	95-110023-24	1	
- 33	95-110026-3	1	
	60-110025-7	1	3
	95-110027-3	1	4
	A6914-1024-1	2	
	95-110022-607	1	
	95-110022-616	1	
- 34	95-110022-37	1	
	95-110022-77	1	
- 35	95-110022-39	1	
	95-110022-79	1	
- 36	95-110022-41	1	
	95-110022-42	1	
- 37	95-110022-43	1	
	95-110022-44	1	
- 38	95-110022-45	1	
- 39	95-110022-47	1	
	95-110022-48	1	
- 40	95-110022-49	1	
	95-110022-50	1	
- 41	95-110022-71	1	
	22A17-82	4	
- 42	35-115395	1	
	35-115395	2	
	95-110022-609	1	
	95-110022-610	1	
- 43	95-110022-51	1	
	95-110022-52	1	
- 44	95-110022-53	1	
	95-110022-54	1	
- 45	95-110022-55	1	
- 46	95-110022-57	1	
	95-110022-58	1	
- 47	95-110022-59	1	
	95-110022-60	1	
- 48	95-110022-61	1	
	95-110022-62	1	
- 49	95-110022-63	1	
	95-110022-64	1	
- 50	35-115395	2	
	AN931-7-11	1	

C O D E S O F E F F E C T I V I T Y

1 P-247 THRU P-334 2 P-335 AND AFTER
3 P-247 THRU P-412 4 P-413 AND AFTER

B E E C H C R A F T
DUKE B60
I L L U S T R A T E D P A R T S C A T A L O G

57-20-01
WING INBOARD LEADING EDGE
P-247 THRU P-266

BEECHCRAFT
DUKE B60
ILLUSTRATED PARTS CATALOG

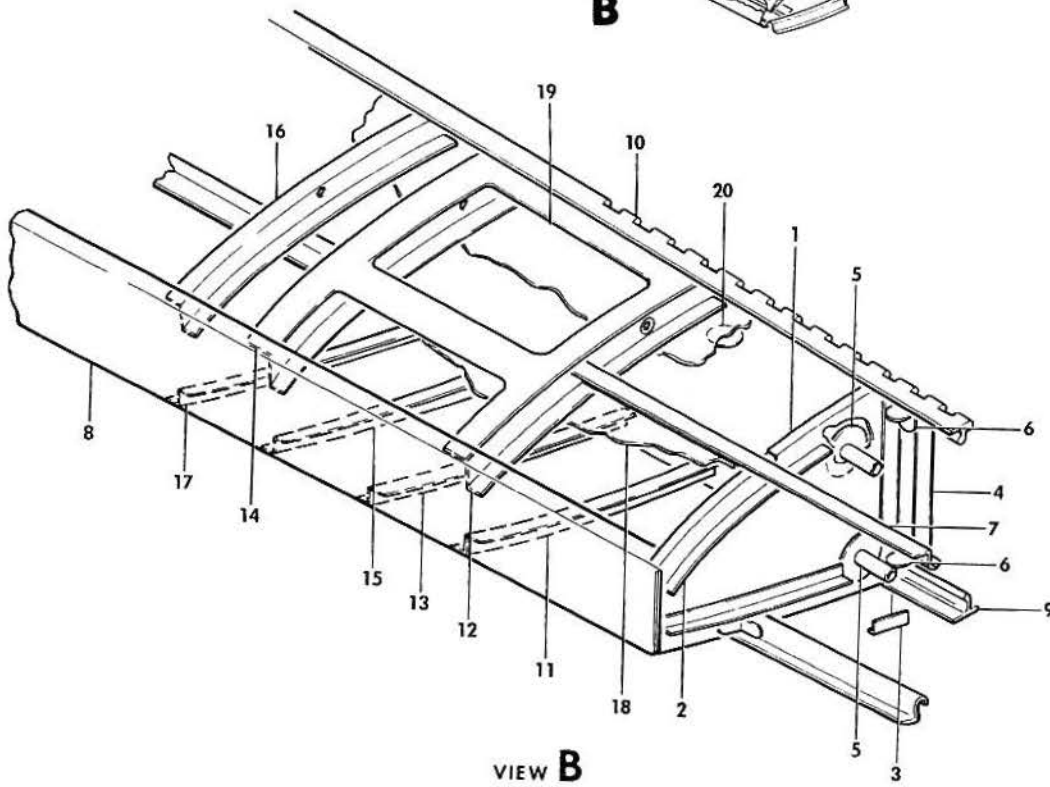
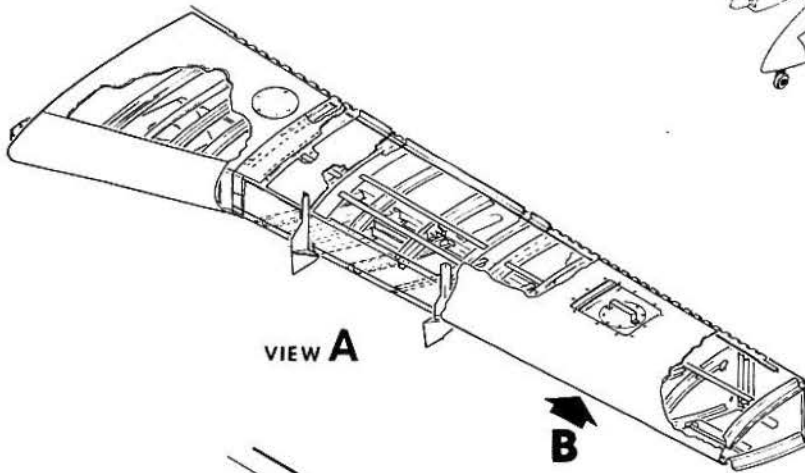

B60-33-8

B E E C H C R A F T
DUKE B60
I L L U S T R A T E D P A R T S C A T A L O G

GAMA/ATA CODE & INDEX NO.	PART NO.	DESCRIPTION							UNITS PER ASSY	USABLE ON CODE
		1	2	3	4	5	6	7		
20-01	60-110012-607	LEADING EDGE ASSY,LH INBD WING.	1	1
	60-110012-608	LEADING EDGE ASSY,RH INBD WING.	1	1
	96-100016-211	. RIB ASSY,LH LEADING EDGE/STA 122.096/	1	1
	96-100016-212	. RIB ASSY,RH LEADING EDGE/STA 122.096/	1	1
- 1	96-100016-213	. . RIB,LH.	1	1
	96-100016-214	. . RIB,RH.	1	1
	96-100016-217	. . ANGLE,LH.	1	1
	96-100016-218	. . ANGLE,RH.	1	1
- 2	96-100016-219	. . ANGLE,LH.	1	1
	96-100016-220	. . ANGLE,RH.	1	1
- 3	96-100016-221	. . ANGLE,LH.	1	1
	96-100016-222	. . ANGLE,RH.	1	1
	96-100016-223	. . ANGLE,LH.	1	1
	96-100016-224	. . ANGLE,RH.	1	1
- 4	96-100016-215	. . ZEE,LH.	1	1
	96-100016-216	. . ZEE,RH.	1	1
	96-100016-225	. . TUBE ASSY,DRAIN AND VENT/STA 122.096/	2	1
	96-100016-227	. . . PLATE	1	1
- 5	96-100016-229	. . . TUBE	1	1
	96-100016-321	. CLIP,STRINGER/UPPER AND LOWER/STA 122.096/	2	1
- 6	96-100016-381	. CLIP,UPPER ANGLE.	1	1
	96-100016-379	. CLIP,LOWER ANGLE.	1	1
- 7	96-100016-275	. STRINGER,LEADING EDGE UPPER LH.	1	1
	96-100016-276	. STRINGER,LEADING EDGE UPPER RH.	1	1
	96-100016-263	. STRINGER,LEADING EDGE LOWER LH.	1	1
	96-100016-264	. STRINGER,LEADING EDGE LOWER RH.	1	1
	35-115431-21	. ANGLE,RIB/STA 122.096/.	1	1
- 8	96-100016-383	. SPAR,INBD LEADING EDGE LH	1	1
	96-100016-384	. SPAR,INBD LEADING EDGE RH	1	1
- 9	35-115431-111	. HINGE HALF,LOWER INBD LEADING EDGE LH	1	1
	35-115431-112	. HINGE HALF,LOWER INBD LEADING EDGE RH	1	1
- 10	96-100016-377	. HINGE HALF,UPPER INBD LEADING EDGE LH	1	1
	96-100016-378	. HINGE HALF,UPPER INBD LEADING EDGE RH	1	1
- 11	35-115431-29	. ZEE,LOWER LH/STA 112.584/	1	1
	35-115431-30	. ZEE,LOWER RH/STA 112.584/	1	1
- 12	35-115431-33	. ZEE,UPPER LH/STA 112.584/	1	1
	35-115431-34	. ZEE,UPPER RH/STA 112.584/	1	1
- 13	95-110041-19	. ZEE,LOWER LH/STA 107.791/	1	1
	95-110041-20	. ZEE,LOWER RH/STA 107.791/	1	1
- 14	35-115431-27	. ZEE,UPPER LH/STA 103.037/	1	1
	35-115431-28	. ZEE,UPPER RH/STA 103.037/	1	1
- 15	35-115431-23	. ZEE,LOWER LH/STA 103.037/	1	1
	35-115431-24	. ZEE,LOWER RH/STA 103.037/	1	1
- 16	95-110041-17	. ZEE,UPPER LH/STA 98.744/	1	1
	95-110041-18	. ZEE,UPPER RH/STA 98.744/	1	1
- 17	95-110041-15	. ZEE,LOWER LH/STA 98.744/	1	1
	95-110041-16	. ZEE,LOWER RH/STA 98.744/	1	1
- 18	96-100016-403	. LINER,FUEL CELL LOWER LH.	1	1
	96-100016-404	. LINER,FUEL CELL LOWER RH.	1	1
	96-100016-415	. LINER ASSY,UPPER LH	1	1
	96-100016-416	. LINER ASSY,UPPER RH	1	1
- 19	96-100016-409	. . LINER,FUEL CELL UPPER LH.	1	1
	96-100016-410	. . LINER,FUEL CELL UPPER RH.	1	1
- 20	000-110172-1	. . RETAINER,FUEL CELL SUPPORT.	12	1

BEECHCRAFT
DUKE 860
ILLUSTRATED PARTS CATALOG

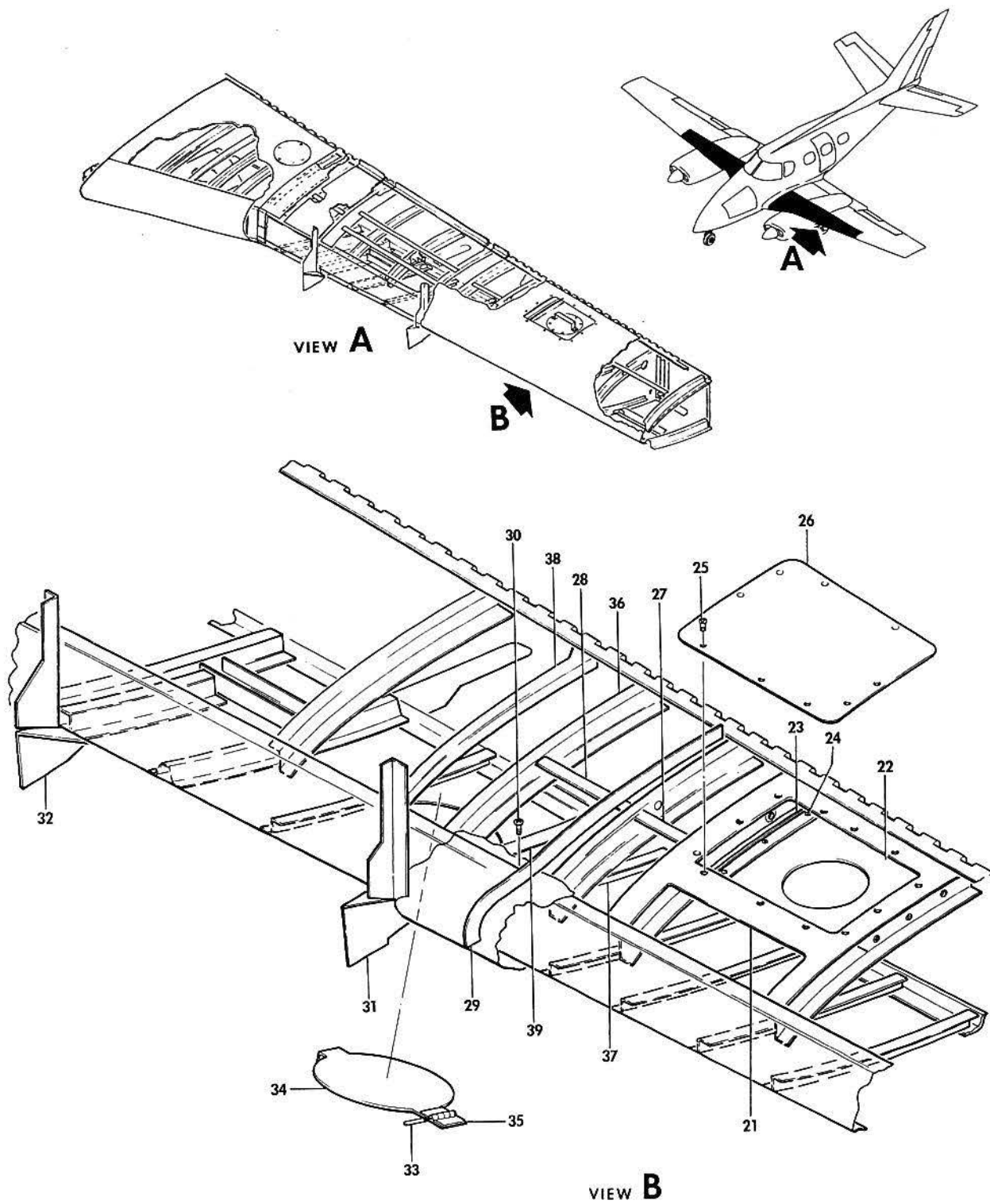

B60-339

B E E C H C R A F T
DUKE 860
I L L U S T R A T E D P A R T S C A T A L O G

GAMA/ATA CODE & INDEX NO.	PART NO.	DESCRIPTION	1 2 3 4 5 6 7							UNITS PER ASSY	USABLE ON CODE
			1	2	3	4	5	6	7		
20-01	96-100016-623	. DOUBLER ASSY,FUEL FILLER LH								1	1
	96-100016-624	. DOUBLER ASSY,FUEL FILLER RH								1	1
- 21	96-100016-125	. . DOUBLER LH.								1	1
	96-100016-126	. . DOUBLER RH.								1	1
- 22	96-100016-121	. PAN,LH FUEL CELL ACCESS								1	1
	96-100016-122	. PAN,RH FUEL CELL ACCESS								1	1
- 23	96-100016-119	. ANGLE,LH FUEL CELL ACCESS/STA 103.037/.								1	1
	96-100016-120	. ANGLE,RH FUEL CELL ACCESS/STA 103.037/.								1	1
		/ATTACHING PARTS/									
- 24	MS27039-0806	. SCREW								3	
	MK1000-08	. NUT PLATE								3	
		-----*									
	96-100016-113	. DOOR ASSY,LH FUEL CELL ACCESS								1	1
	96-100016-114	. DOOR ASSY,RH FUEL CELL ACCESS								1	1
		/ATTACHING PARTS/									
- 25	AN509-8R8	. SCREW								12	
	MS21047-08K	. NUTPLATE.								12	
		-----*									
	96-100016-115	. . DOUBLER,LH.								1	1
	96-100016-116	. . DOUBLER,RH.								1	1
- 26	96-100016-117	. . DOOR,LH FUEL CELL ACCESS.								1	1
	96-100016-118	. . DOOR,RH FUEL CELL ACCESS.								1	1
	MS35489-6	. GROMMET,WING/STA 103.037/								1	1
- 27	95-110041-11	. STRINGER,UPPER LEADING EDGE LH.								1	1
	95-110041-12	. STRINGER,UPPER LEADING EDGE RH.								1	1
- 28	95-110041-5	. STRINGER,UPPER LEADING EDGE LH.								1	1
	95-110041-6	. STRINGER,UPPER LEADING EDGE RH.								1	1
- 29	60-110012-71	. ANGLE,LH/STA 98.74/								1	1
	60-110012-72	. ANGLE,RH/STA 98.74.								1	1
		/ATTACHING PARTS/									
- 30	MS27039-1-08	. SCREW								7	
	NAS680A3	. NUTPLATE/SUPERSEDES AN366F1032/								7	
		-----*									
- 31	60-980026-1	. TEE,LH NACELLE ATTACH/STA 89.189/								1	1
	60-980026-2	. TEE,RH NACELLE ATTACH/STA 89.189/								1	1
- 32	60-980026-3	. TEE,LH NACELLE ATTACH/STA 69.33/.								1	1
	60-980026-4	. TEE,RH NACELLE ATTACH/STA 69.33/.								1	1
	NAS1024A3	. NUTPLATE.								9	1
	MS35489-11	. GROMMET/STA 91.30/								1	1
	60-110014-601	. DOOR ASSY,FUEL CELL INTERCONNECT ACCESS								1	1
		/ATTACHING PARTS/									
- 33	102361-00200	. PIN,HINGE								1	
		-----*									
- 34	60-110014-1	. . DOOR,FUEL CELL INTERCONNECT ACCESS.								1	1
	60-110014-5	. . STIFFENER,ACCESS DOOR								1	1
- 35	60-110014-3	. . HINGE,ACCESS DOOR HALF.								2	1
	22NA17A02	. NUTPLATE.								4	1
	AN366F1032	. NUTPLATE.								8	1
- 36	35-115431-39	. ZEE,LEADING EDGE UPPER LH/STA 92.721/								1	1
	35-115431-40	. ZEE,LEADING EDGE UPPER RH/STA 92.721/								1	1
- 37	35-115431-117	. ZEE,LEADING EDGE LOWER LH/STA 92.721/								1	1
	35-115431-118	. ZEE,LEADING EDGE LOWER RH/STA 92.721/								1	1
- 38	96-100016-105	. ANGLE,UPPER LH/STA 89.264/.								1	1
	96-100016-106	. ANGLE,UPPER RH/STA 89.264/.								1	1
- 39	96-100016-385	. FORMER,LOWER LH/STA 89.264/								1	1
	96-100016-386	. FORMER,LOWER RH/STA 89.264/								1	1

BEECHCRAFT
DUKE 860
ILLUSTRATED PARTS CATALOG

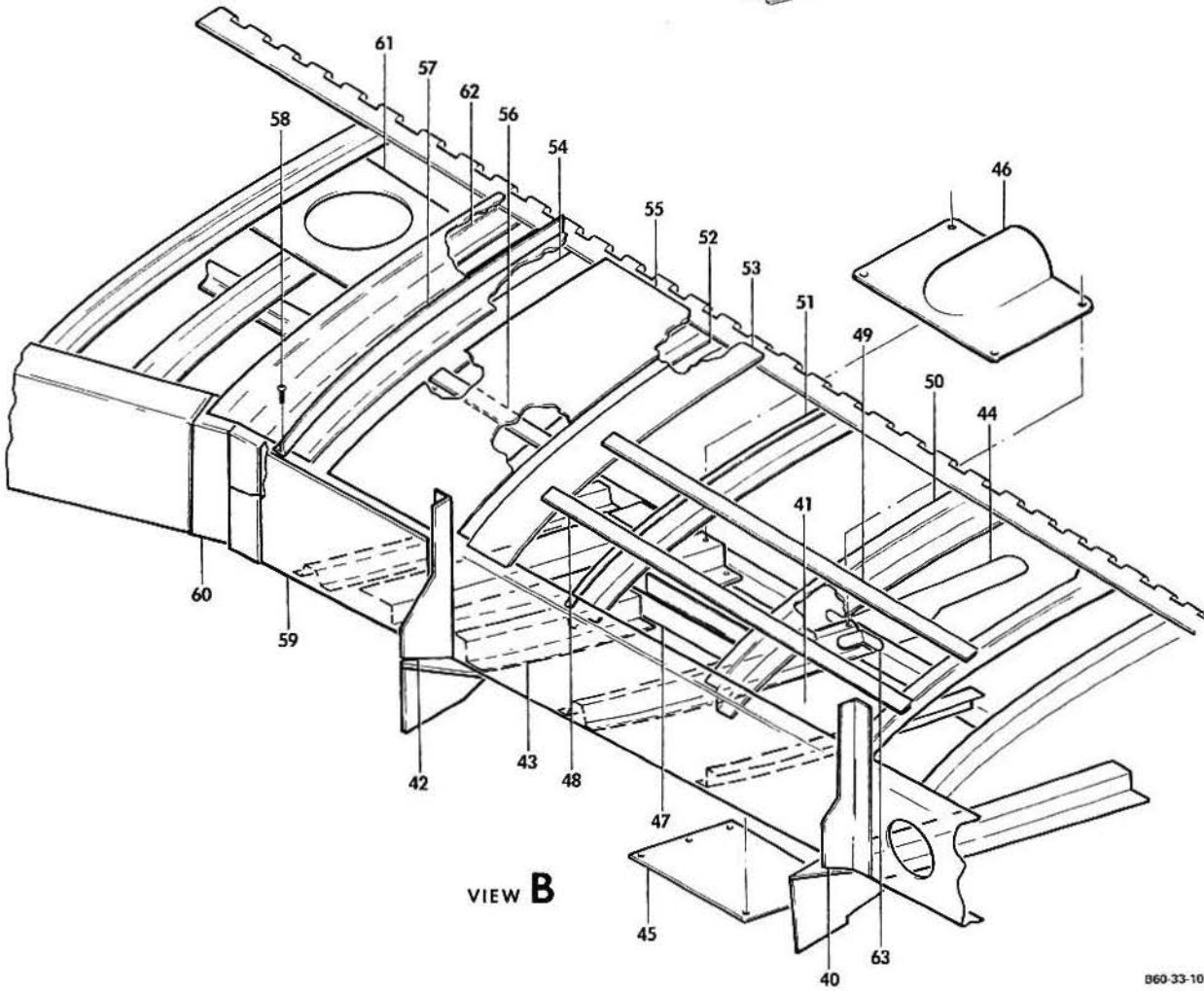
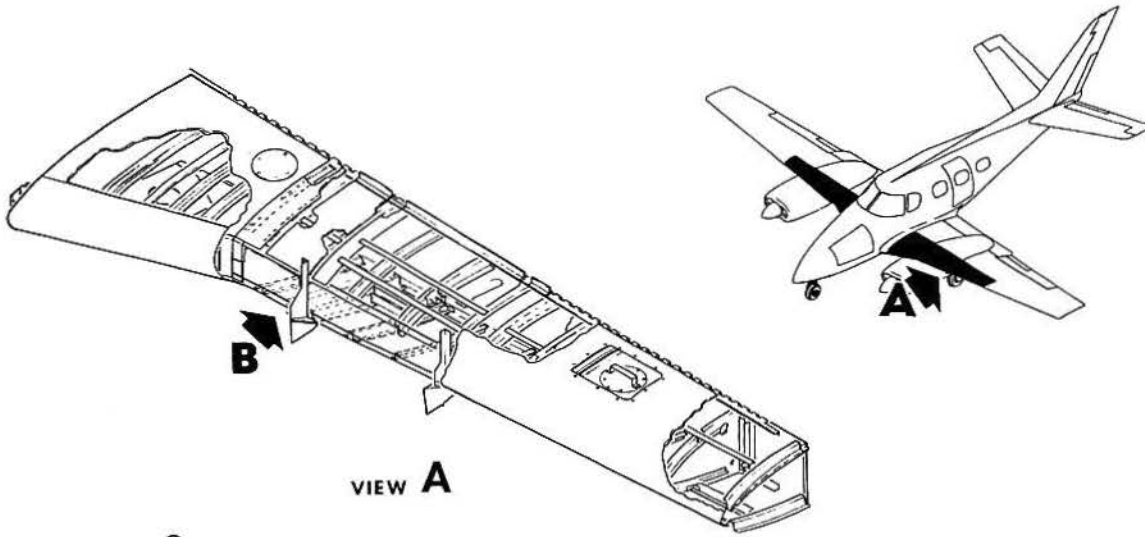

860-33-10

B E E C H C R A F T
DUKE B60
I L L U S T R A T E D P A R T S C A T A L O G

GAMA/ATA CODE & INDEX NO.	PART NO.	DESCRIPTION	1 2 3 4 5 6 7							UNITS PER ASSY	USABLE ON CODE
20-01 - 40	96-100016-135	• ANGLE,LH LEADING EDGE/STA 89.35/								1	1
	96-100016-136	• ANGLE,RH LEADING EDGE/STA 89.35/								1	1
- 41	96-100016-11	• DOUBLER,LEADING EDGE LH								1	1
	96-100016-12	• DOUBLER,LEADING EDGE RH								1	1
- 42	96-100016-393	• ANGLE,LOWER LH/STA 69.17/								1	1
	96-100016-394	• ANGLE,LOWER RH/STA 69.17/								1	1
- 43	96-100016-389	• FORMER,LOWER LH LEADING EDGE/STA 69.33/								1	1
	96-100016-390	• FORMER,LOWER RH LEADING EDGE/STA 69.33/								1	1
- 44	96-100016-27	• STRAP,LH/STA 74.924/								1	1
	96-100016-28	• STRAP,RH/STA 74.924/								1	1
	96-100016-341	• SPACER								1	1
	MS21047-08	• NUTPLATE								2	1
	22NA17A82	• NUTPLATE								2	1
	MS21047L08	• NUTPLATE								1	1
- 45	35-115431-173	• DOOR,LANDING GEAR ACCESS								1	1
		/ATTACHING PARTS/									
	MS24694S5	• SCREW								8	
- 46	000-110179-1	• COVER,ACCESS DOOR								1	1
- 47	96-100016-109	• CHANNEL,LANDING GEAR ACCESS DOOR LH								1	1
	96-100016-110	• CHANNEL,LANDING GEAR ACCESS DOOR RH								1	1
- 48	96-100016-167	• STRINGER,UPPER LEADING EDGE LH								1	1
	96-100016-168	• STRINGER,UPPER LEADING EDGE RH								1	1
- 49	96-100016-169	• STRINGER,UPPER LEADING EDGE LH								1	1
	96-100016-170	• STRINGER,UPPER LEADING EDGE RH								1	1
- 50	35-115431-45	• ZEE,UPPER LEADING EDGE LH/STA 81.943/								1	1
	35-115431-46	• ZEE,UPPER LEADING EDGE RH/STA 81.943/								1	1
- 51	95-110015-29	• FORMER,UPPER LH/STA 74.924/								1	1
	95-110015-30	• FORMER,UPPER RH/STA 74.924/								1	1
- 52	95-110015-25	• FORMER,UPPER LH/STA 67.924/								1	1
	95-110015-26	• FORMER,UPPER RH/STA 67.924/								1	1
- 53	96-100016-23	• DOUBLER,UPPER LH/STA 67.924/								1	1
	96-100016-24	• DOUBLER,UPPER RH/STA 67.924/								1	1
- 54	96-100016-201	• FORMER,UPPER LH/STA 61.924/								1	1
	96-100016-202	• FORMER,UPPER RH/STA 61.924/								1	1
- 55	96-100016-155	• DOUBLER,UPPER LH/STA 62 TO 68/								1	1
	96-100016-156	• DOUBLER,UPPER RH/STA 62 TO 68/								1	1
- 56	50-110010-52	• STRINGER,LH								1	1
	50-110010-53	• STRINGER,RH								1	1
- 57	96-100016-39	• ANGLE,LH/STA 60.42/								1	1
	96-100016-40	• ANGLE,RH/STA 60.42/								1	1
		/ATTACHING PARTS/									
- 58	MS27039-1-08	• SCREW								6	
	NAS680A3	• NUTPLATE								6	
- 59	96-100016-177	• DOUBLER,LEADING EDGE								1	1
- 60	96-100016-205	• SPLICE,LH/STA 55.92/								1	1
	96-100016-206	• SPLICE,RH/STA 55.92/								1	1
- 61	96-100016-203	• DOUBLER,FORMER UPPER LH/STA 49 TO 62/								1	1
	96-100016-204	• DOUBLER,FORMER UPPER RH/STA 49 TO 62/								1	1
- 62	96-100016-189	• FORMER,UPPER LH/STA 55.924/								1	1
	96-100016-190	• FORMER,UPPER RH/STA 55.924/								1	1
	MS35489-4	• GROMMET								5	1
	22NA1K82	• NUTPLATE								6	1
	MS21047L08	• NUTPLATE								6	1
	MK4000-08	• NUTPLATE								2	1
- 63	35-115212	• CLIP,FUEL CELL LINER TO STRINGER LH								11	1
	35-115212-1	• CLIP,FUEL CELL LINER TO STRINGER RH								11	1

BEECHCRAFT
DUKE B60
ILLUSTRATED PARTS CATALOG

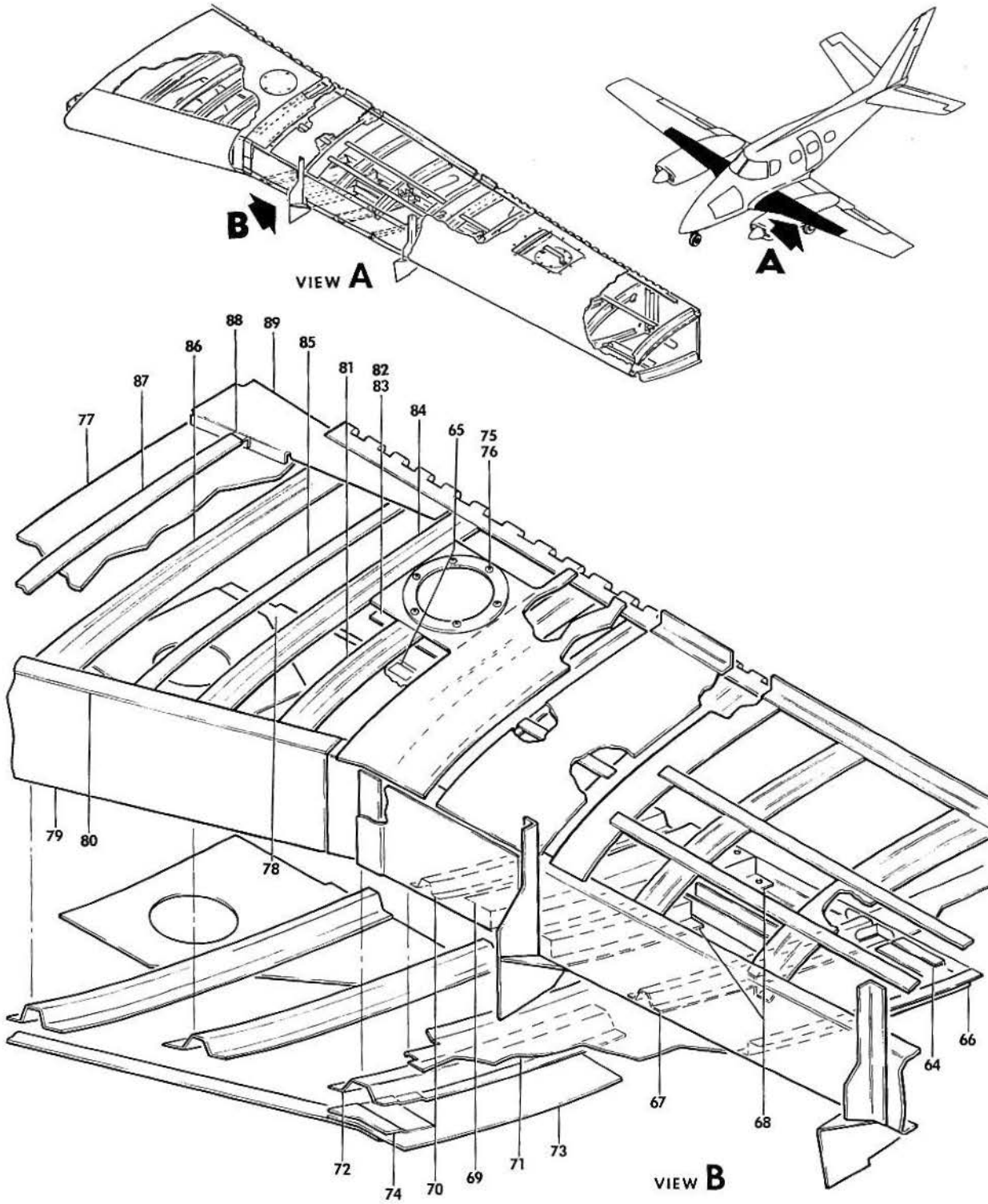

B60-33-11

B E E C H C R A F T
DUKE 860
I L L U S T R A T E D P A R T S C A T A L O G

GAMA/ATA CODE & INDEX NO.	PART NO.	DESCRIPTION	UNITS PER ASSY	USABLE ON CODE
		1 2 3 4 5 6 7		
20-01 - 64	50-110010-34	. SUPPORT, LOWER LEADING EDGE LH & RH.	4	1
- 65	50-110010-36	. SUPPORT, LOWER LEADING EDGE LH & RH.	2	1
	AN520-10	. SCREW, ACCESS DOOR/STA 81.024/	1	1
	NAS680A3	. NUTPLATE.	1	1
- 66	96-100016-67	. ZEE, LEADING EDGE LOWER LH/STA 81.024/	1	1
	96-100016-68	. ZEE, LEADING EDGE LOWER RH/STA 81.024/	1	1
- 67	95-110015-31	. FORMER, LOWER LH/STA 74.924/	1	1
	95-110015-32	. FORMER, LOWER RH/STA 74.924/	1	1
- 68	96-100016-391	. ZEE, LOWER LH/STA 67.924/	1	1
	96-100016-392	. ZEE, LOWER RH/STA 67.924/	1	1
	35-115214	. CLIP, LOWER LH	1	1
	35-115214-1	. CLIP, LOWER RH	1	1
- 69	96-100016-359	. ZEE, LOWER LH/STA 65.674/	1	1
	96-100016-360	. ZEE, LOWER RH/STA 65.674/	1	1
- 70	96-100016-339	. FORMER, LOWER LH/STA 61.924/	1	1
	96-100016-340	. FORMER, LOWER RH/STA 61.924/	1	1
- 71	96-100016-387	. DOUBLER, LOWER LH/STA 56 TO 68/	1	1
	96-100016-388	. DOUBLER, LOWER RH/STA 56 TO 68/	1	1
- 72	96-100016-347	. FORMER, LOWER LH/STA 55.924/	1	1
	96-100016-348	. FORMER, LOWER RH/STA 55.924/	1	1
- 73	96-100016-345	. DOUBLER, LOWER LH/STA 55.924/	1	1
	96-100016-346	. DOUBLER, LOWER RH/STA 55.924/	1	1
- 74	96-100016-175	. DOUBLER, LOWER LH/STA 55.924/	1	1
	96-100016-176	. DOUBLER, LOWER RH/STA 55.924/	1	1
- 75	60-110032	. COVER, FUEL TRANSMITTER ACCESS/STA 51.95/ /ATTACHING PARTS/	1	1
- 76	AN507-632-8	. SCREW	6	
	MS21047-06K	. NUTPLATE.	6	
		*		
	96-100016-405	. LINER ASSY, FUEL CELL UPPER LH	1	1
	96-100016-406	. LINER ASSY, FUEL CELL UPPER RH	1	1
- 77	96-100016-417	. . LINER, LH.	1	1
	96-100016-418	. . LINER, RH.	1	1
	000-110172-1	. . RETAINER, FUEL CELL SUPPORT.	6	1
- 78	96-100016-407	. LINER, FUEL CELL LOWER LH.	1	1
	96-100016-408	. LINER, FUEL CELL LOWER RH.	1	1
- 79	60-110012-61	. SPAR, INBOARD LEADING EDGE LH.	1	1
	60-110012-62	. SPAR, INBOARD LEADING EDGE RH.	1	1
- 80	96-100016-191	. SPACER, LEADING EDGE SPAR UPPER.	1	1
	96-100016-193	. SPACER, LEADING EDGE SPAR LOWER.	1	1
- 81	96-100016-141	. FORMER, UPPER LH/STA 51.95/	1	1
	96-100016-142	. FORMER, UPPER RH/STA 51.95/	1	1
- 82	96-100016-143	. ANGLE	1	1
- 83	96-100016-145	. CLIP, OUTBOARD	1	1
	96-100016-146	. CLIP, INBOARD.	1	1
- 84	96-100016-185	. FORMER, UPPER LH/STA 48.299/	1	1
	96-100016-186	. FORMER, UPPER RH/STA 48.299/	1	1
- 85	96-100016-147	. ZEE, UPPER LH/STA 44.48/	1	1
	96-100016-148	. ZEE, UPPER RH/STA 44.48/	1	1
- 86	96-100016-181	. FORMER, UPPER LH/STA 40.674/	1	1
	60-110012-59	. FORMER, UPPER RH/STA 40.674/	1	1
- 87	96-100016-151	. ZEE, UPPER LH.	1	1
	96-100016-152	. ZEE, UPPER RH.	1	1
- 88	96-100016-149	. CLIP.	1	1
- 89	50-110056-2	. GUSSET, LEADING EDGE UPPER LH.	1	1
	50-110056-3	. GUSSET, LEADING EDGE UPPER RH.	1	1

BEECHCRAFT
DUKE B60
ILLUSTRATED PARTS CATALOG

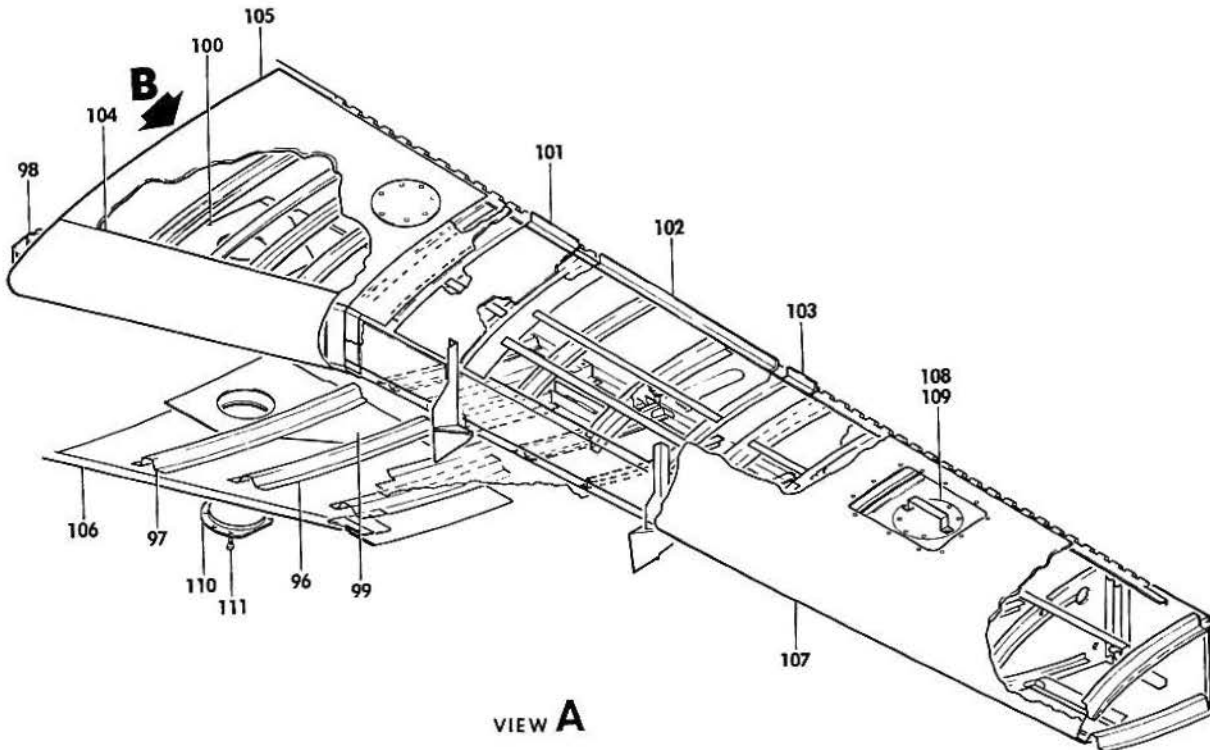
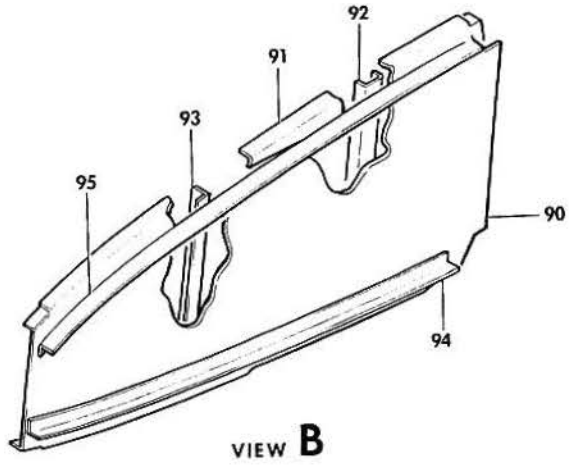
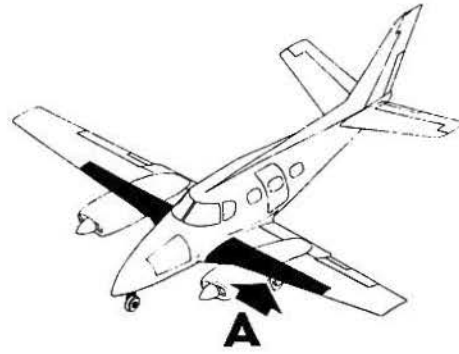

B60-33-12

B E E C H C R A F T
DUKE 860
I L L U S T R A T E D P A R T S C A T A L O G

GAMA/ATA CODE & INDEX NO.	PART NO.	DESCRIPTION	1 2 3 4 5 6 7							UNITS PER ASSY	USABLE ON CODE
			1	2	3	4	5	6	7		
20-01	60-110018-603	. RIB ASSY, LEADING EDGE LH/STA 32.805/	1	1
	60-110018-604	. RIB ASSY, LEADING EDGE RH/STA 32.805/	1	1
- 90	60-110018-16	. . RIB, ROOT LH	1	1
	60-110018-6	. . RIB, ROOT RH	1	1
	60-110019-5	. . REINFORCEMENT, ROOT RIB LH	1	1
	60-110019-6	. . REINFORCEMENT, ROOT RIB RH	1	1
- 91	50-110046-8	. . ANGLE, ROOT RIB LH	1	1
	50-110046-9	. . ANGLE, ROOT RIB RH	1	1
- 92	50-110010-165	. . STIFFENER, ROOT RIB	1	1
- 93	60-110018-7	. . STIFFENER, ROOT RIB	1	1
- 94	60-110018-11	. ANGLE, ROOT RIB LOWER LH	1	1
	60-110018-12	. ANGLE, ROOT RIB LOWER RH	1	1
- 95	60-110018-13	. ANGLE, ROOT RIB UPPER LH	1	1
	60-110018-14	. ANGLE, ROOT RIB UPPER RH	1	1
- 96	96-100016-183	. FORMER, LOWER LH/STA 48.299/	1	1
	96-100016-184	. FORMER, LOWER RH/STA 48.299/	1	1
- 97	96-100016-3	. FORMER, LOWER LH/STA 40.674/	1	1
	96-100016-4	. FORMER, LOWER RH/STA 40.674/	1	1
- 98	60-110021-1	. SUPPORT, WING LEADING EDGE SHEAR TIE LH	1	1
	60-110021-2	. SUPPORT, WING LEADING EDGE SHEAR TIE RH	1	1
- 99	60-110013-3	. GUSSET, LEADING EDGE LOWER LH	1	1
	60-110013-4	. GUSSET, LEADING EDGE LOWER RH	1	1
-100	60-921011-1	. BRACKET, LH FUEL BOOST PUMP MOUNTING	1	1
	60-921011-2	. BRACKET, RH FUEL BOOST PUMP MOUNTING	1	1
-101	60-980000-21	. ANGLE, LH NACELLE/STA 69.26/	1	1
	60-980000-22	. ANGLE, RH NACELLE/STA 69.26/	1	1
-102	60-980000-67	. ANGLE, LH NACELLE/STA 79.26/	1	1
	60-980000-68	. ANGLE, RH NACELLE/STA 79.26/	1	1
-103	60-980000-139	. ANGLE, LH NACELLE/STA 89.26/	1	1
	60-980000-140	. ANGLE, RH NACELLE/STA 89.26/	1	1
	60-540018	. SUPPORT, PRESSURIZATION DUCT	3	1
		/ATTACHING PARTS/									
	AN515-8R14	. SCREW	1	
	AN515-8R26	. SCREW	1	
-104	60-110016-53	. SKIN, INBD LEADING EDGE LH/STA 32.8 TO 55.9/	1	1
	60-110012-54	. SKIN, INBD LEADING EDGE RH/STA 32.8 TO 55.9/	1	1
		/ATTACHING PARTS/									
	AN509-832-8	. SCREW	29	
	NAS697A08	. NUTPLATE	29	
-105	60-110012-55	. SKIN, INBD LEADING EDGE UPPER LH	1	1
	60-110012-56	. SKIN, INBD LEADING EDGE UPPER RH	1	1
-106	60-110012-57	. SKIN, INBD LEADING EDGE LOWER LH	1	1
	60-110012-58	. SKIN, INBD LEADING EDGE LOWER RH	1	1
-107	96-100016-367	. SKIN, LEADING EDGE LH/STA 55.9 TO 131.67/	1	1
	96-100016-368	. SKIN, LEADING EDGE RH/STA 55.9 TO 131.67/	1	1
-108	60-921025	PLATE ASSY, FUEL CELL ACCESS CLOSURE	1	1
		/ATTACHING PARTS/									
	MS20073-04-07	BOLT	12	
	AN960-416L	WASHER	12	
-109	35-921502-1	GASKET, FUEL CELL ACCESS PLATE	1	1
	60-921027-1	BRACKET ASSY, FUEL CELL ACCESS COVER MOUNTING	1	1
-110	R 000-110240-1	DOOR ASSY, FUEL BOOST PUMP ACCESS LH	1	1
	R 000-110240-2	DOOR ASSY, FUEL BOOST PUMP ACCESS RH	1	1
		/ATTACHING PARTS/									
-111	AN509-10R7	SCREW	8	
	MS35489-2S	GROMMET, BOOST PUMP ACCESS DOOR	1	1

CODES OF EFFECTIVITY

1 P-247 THRU P-266

B E E C H C R A F T
DUKE 860
I L L U S T R A T E D P A R T S C A T A L O G

57-20-02
WING INBOARD LEADING EDGE
P-267 AND AFTER

BEECHCRAFT
DUKE B60
ILLUSTRATED PARTS CATALOG

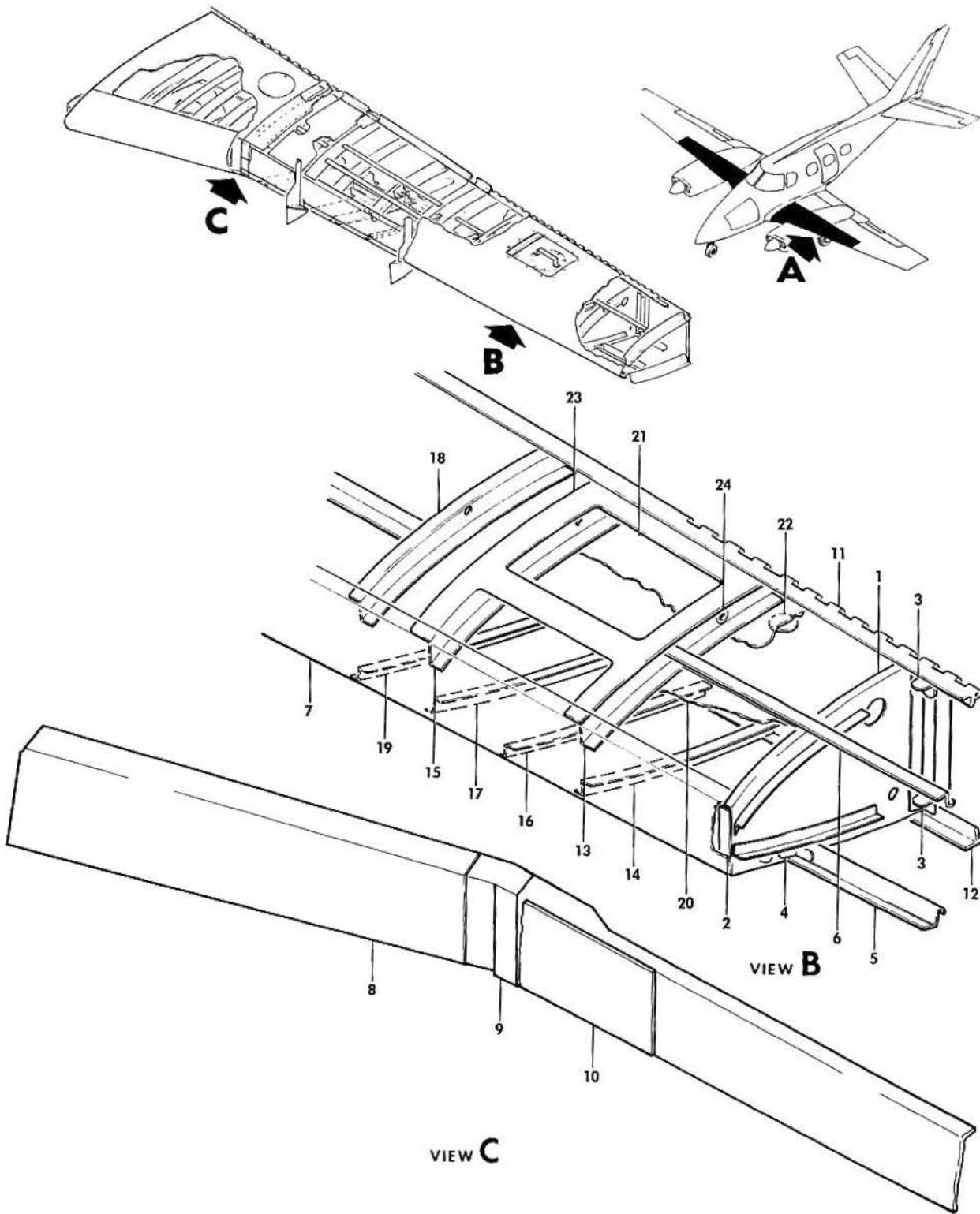

B60-33-3

B E E C H C R A F T
DUKE B60
I L L U S T R A T E D P A R T S C A T A L O G

GAMA/ATA CODE & INDEX NO.	PART NO.	DESCRIPTION	UNITS PER ASSY	USABLE ON CODE		
					1	2
20-02	60-110012-611	LEADING EDGE ASSY,LH INBD WING.	1	1		
	60-110012-612	LEADING EDGE ASSY,RH INBD WING.	1	1		
	000-110107-13	. RIB ASSY,LH LEADING EDGE/STA 122.096/	1	1		
	000-110107-14	. RIB ASSY,RH LEADING EDGE/STA 122.096/	1	1		
- 1	000-110107-1	. . RIB,LH.	1	1		
	000-110107-2	. . RIB,RH.	1	1		
	000-110107-11	. . DOUBLER,RIB/STA 122.096/.	1	1		
- 2	000-110107-5	. ANGLE,RIB/STA 122.096/.	1	1		
- 3	000-110117-7	. CLIP,RIB/STA 122.096/	2	1		
- 4	000-110117-3	. CLIP,STRINGER TIE	3	1		
- 5	96-100016-263	. STRINGER,LEADING EDGE LOWER LH.	1	1		
	96-100016-264	. STRINGER,LEADING EDGE LOWER RH.	1	1		
- 6	96-100016-275	. STRINGER,LEADING EDGE UPPER LH.	1	1		
	96-100016-276	. STRINGER,LEADING EDGE UPPER RH.	1	1		
	60-110012-625	. SPAR ASSY,INBOARD LEADING EDGE LH	1	1		
	60-110012-626	. SPAR ASSY,INBOARD LEADING EDGE RH	1	1		
- 7	96-100016-383	. . SPAR,INBOARD LEADING EDGE LH.	1	1		
	96-100016-384	. . SPAR,INBOARD LEADING EDGE RH.	1	1		
- 8	96-100016-61	. . SPAR,INBOARD LEADING EDGE LH.	1	1		
	96-100016-62	. . SPAR,INBOARD LEADING EDGE RH.	1	1		
- 9	96-100016-205	. . SPLICE,SPAR LH/STA 55.924/.	1	1		
	96-100016-206	. . SPLICE,SPAR RH/STA 55.924/.	1	1		
- 10	96-100016-177	. . DOUBLER,OUTBD SPAR/STA 55.92 TO 67.92/.	1	1		
	MS21047L08	. . NUTPLATE.	6	1		
	22NA1K82	. . NUTPLATE.	3	1		
- 11	000-110083-5	. HINGE,UPPER INBOARD LH & RH	1	1		
- 12	000-110083-7	. HINGE,LOWER INBOARD LH & RH	1	1		
- 13	000-110151-1	. REINFORCEMENT,UPPER LH/STA 112.584/	1	1		
	000-110151-2	. REINFORCEMENT,UPPER RH/STA 112.584/	1	1		
- 14	000-110149-1	. REINFORCEMENT,LOWER LH/STA 112.584/	1	1		
	000-110149-2	. REINFORCEMENT,LOWER RH/STA 112.584/	1	1		
- 15	000-110148-1	. REINFORCEMENT,UPPER LH/STA 103.037/	1	1		
	000-110148-2	. REINFORCEMENT,UPPER RH/STA 103.037/	1	1		
- 16	000-110136-9	. STIFFENER,LOWER LH/STA 107.791/	1	1		
	000-110136-10	. STIFFENER,LOWER RH/STA 107.791/	1	1		
- 17	000-110147-1	. REINFORCEMENT,LOWER LH/STA 103.037/	1	1		
	000-110147-2	. REINFORCEMENT,LOWER RH/STA 103.037/	1	1		
- 18	000-110136-5	. STIFFENER,UPPER LH/STA 98.744/.	1	1		
	000-110136-6	. STIFFENER,UPPER RH/STA 98.744/.	1	1		
- 19	000-110136-7	. STIFFENER,LOWER LH/STA 98.744/.	1	1		
	000-110136-8	. STIFFENER,LOWER RH/STA 98.744/.	1	1		
- 20	96-100016-403	. LINER,FUEL CELL LOWER LH.	1	1		
	96-100016-404	. LINER,FUEL CELL LOWER RH.	1	1		
	96-100016-415	. LINER ASSY,LEADING EDGE UPPER LH.	1	1		
	96-100016-416	. LINER ASSY,LEADING EDGE UPPER RH.	1	1		
- 21	96-100016-409	. . LINER,FUEL CELL UPPER LH.	1	1		
	96-100016-410	. . LINER,FUEL CELL UPPER RH.	1	1		
- 22	000-110172-1	. . RETAINER,FUEL CELL SUPPORT.	12	1		
	96-100016-623	. DOUBLER ASSY,FUEL FILLER LH	1	1		
	96-100016-624	. DOUBLER ASSY,FUEL FILLER RH	1	1		
- 23	96-100016-125	. . DOUBLER,LH.	1	1		
	96-100016-126	. . DOUBLER,RH.	1	1		
	22NA38-83BC	. . NUTPLATE.	3	1		
- 24	MS35489-6	. GROMMET	1	1		

BEECHCRAFT
DUKE B60
ILLUSTRATED PARTS CATALOG

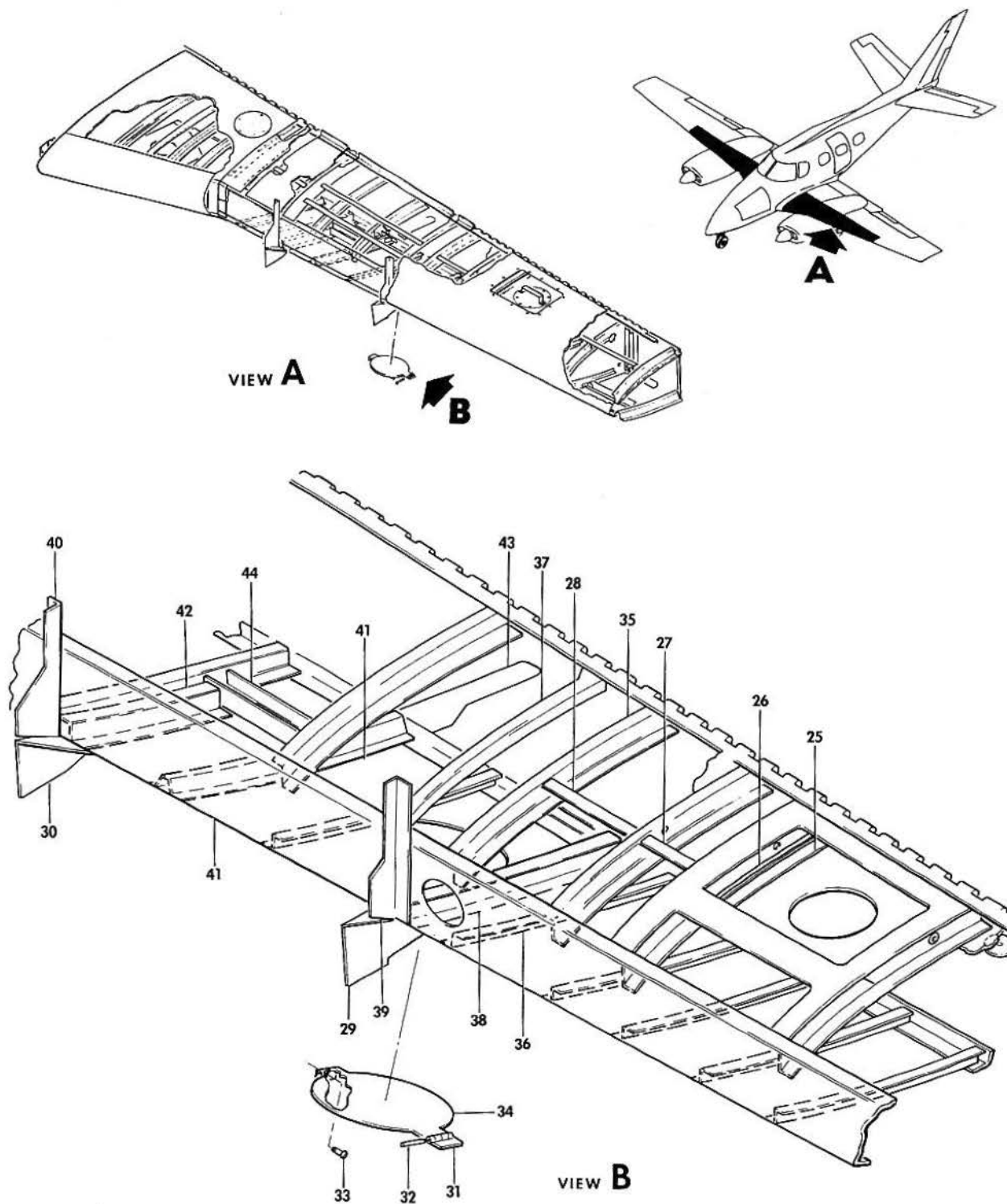

B60-33-4

B E E C H C R A F T
DUKE 860
I L L U S T R A T E D P A R T S C A T A L O G

GAMA/ATA CODE & INDEX NO.	PART NO.	DESCRIPTION							UNITS PER ASSY	USABLE ON CODE
		1	2	3	4	5	6	7		
20-02 - 25	96-100016-121	1	1
	96-100016-122	1	1
		/ATTACHING PARTS/								
	MS27039-0806	6	
	MK1000-08	6	
		*								
- 26	96-100016-119	1	1
	96-100016-120	1	1
- 27	95-110041-11	1	1
	95-110041-12	1	1
- 28	95-110041-5	1	1
	95-110041-6	1	1
- 29	60-980026-1	1	1
	60-980026-2	1	1
- 30	60-980026-3	1	1
	60-980026-4	1	1
	NAS1024A3	9	1
- 31	000-110157-5	1	1
	000-110157-1	1	1
		/ATTACHING PARTS/								
- 32	102361-00200	1	
- 33	AN520-10-6	1	
	R 130909N33	1	
		*								
	000-110157-5	1	1
	000-110157-7	1	1
- 34	000-110157-3	1	1
	22NA17A02	4	1
	AN366F1032	8	1
- 35	000-110152-1	1	1
	000-110152-2	1	1
- 36	000-110136-3	1	1
	000-110136-4	1	1
- 37	96-100016-105	1	1
	96-100016-106	1	1
- 38	000-110135-27	1	1
	000-110135-28	1	1
- 39	96-100016-135	1	1
	96-100016-136	1	1
- 40	96-100016-393	1	1
	96-100016-394	1	1
- 41	000-110160-1	1	1
- 42	96-100016-389	1	1
	96-100016-390	1	1
- 43	96-100016-27	1	1
	96-100016-28	1	1
	96-100016-341	1	1
	96-100016-109	1	1
	96-100016-110	1	1
- 44	96-100016-357	1	1
	96-100016-358	1	1
	NAS1024A3	1	1
	22A17-82	2	1
	MS21047L08	1	1

BEECHCRAFT
DUKE 860
ILLUSTRATED PARTS CATALOG

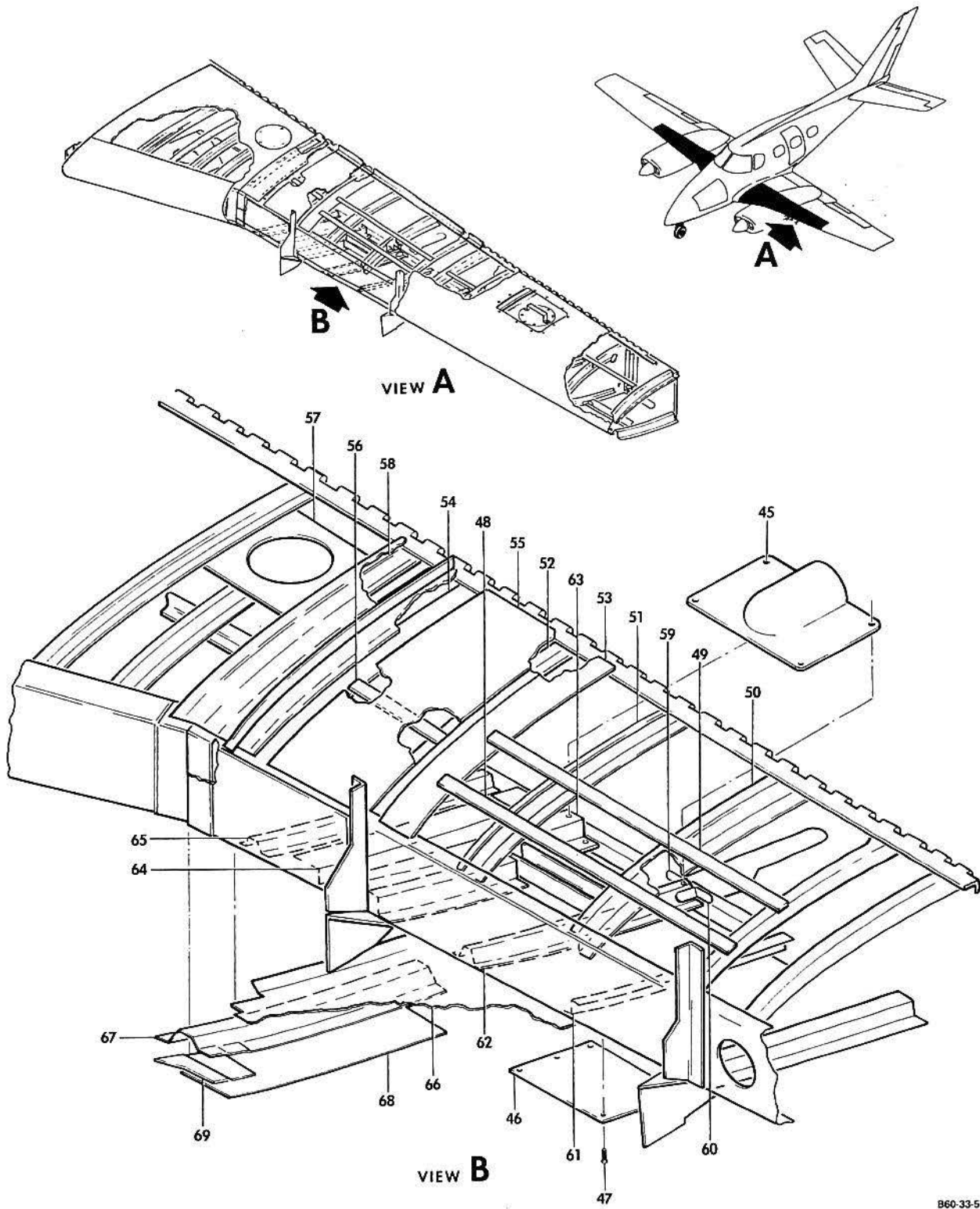

B60-33-5

B E E C H C R A F T
DUKE B60
I L L U S T R A T E D P A R T S C A T A L O G

GAMA/ATA CODE & INDEX NO.	PART NO.	DESCRIPTION	1 2 3 4 5 6 7							UNITS PER ASSY	USABLE ON CODE
			1	2	3	4	5	6	7		
20-02	MS21047-08	. NUTPLATE.								2	1
	22NA17A82	. NUTPLATE.								2	1
- 45	000-110179-1	. COVER,ACCESS DOOR								1	1
- 46	35-115431-173	. DOOR,LANDING GEAR ACCESS. /ATTACHING PARTS/								1	1
- 47	MS24694S5	. SCREW								8	1
- 48	96-100016-167	. STRINGER,LEADING EDGE UPPER LH.								1	1
	96-100016-168	. STRINGER,LEADING EDGE UPPER RH.								1	1
- 49	96-100016-169	. STRINGER,LEADING EDGE UPPER LH.								1	1
	96-100016-170	. STRINGER,LEADING EDGE UPPER RH.								1	1
- 50	000-110154-1	. ZEE,LEADING EDGE UPPER LH/STA 81.943/								1	1
	000-110154-2	. ZEE,LEADING EDGE UPPER RH/STA 81.943/								1	1
- 51	000-110135-23	. FORMER,LEADING EDGE UPPER LH/STA 74.924/								1	1
	000-110135-24	. FORMER,LEADING EDGE UPPER RH/STA 74.924/								1	1
- 52	95-110015-25	. FORMER,LEADING EDGE UPPER LH/STA 67.924/								1	1
	95-110015-26	. FORMER,LEADING EDGE UPPER RH/STA 67.924/								1	1
- 53	96-100016-23	. DOUBLER,UPPER LH.								1	1
	96-100016-24	. DOUBLER,UPPER RH.								1	1
- 54	96-100016-201	. FORMER,LEADING EDGE UPPER LH/STA 61.924/								1	1
	96-100016-202	. FORMER,LEADING EDGE UPPER RH/STA 61.924/								1	1
- 55	96-100016-155	. DOUBLER,UPPER LH/STA 62 TO 68/								1	1
	96-100016-156	. DOUBLER,UPPER RH/STA 62 TO 68/								1	1
- 56	50-110010-52	. STRINGER,UPPER LH								1	1
	50-110010-53	. STRINGER,UPPER RH								1	1
	NAS680A3	. NUTPLATE.								13	1
- 57	96-100016-203	. DOUBLER,UPPER LH/STA 49 TO 62/								1	1
	96-100016-204	. DOUBLER,UPPER RH/STA 49 TO 62/								1	1
- 58	96-100016-189	. FORMER,UPPER LH/STA 55.924/								1	1
	96-100016-190	. FORMER,UPPER RH/STA 55.924/								1	1
	22NA1K82	. NUTPLATE.								9	1
	MS21047L08	. NUTPLATE.								4	1
- 59	000-110117-1	. CLIP,FORMER UPPER AND LOWER								12	1
- 60	000-110117-2	. CLIP,FORMER UPPER AND LOWER								12	1
- 61	000-110136-1	. STIFFENER,LEADING EDGE LOWER LH/STA 81.024/								1	1
	000-110136-2	. STIFFENER,LEADING EDGE LOWER RH/STA 81.024/								1	1
- 62	000-110135-25	. FORMER,LEADING EDGE LOWER LH/STA 74.924/								1	1
	000-110135-26	. FORMER,LEADING EDGE LOWER RH/STA 74.924/								1	1
- 63	96-100016-391	. ZEE,LEADING EDGE LOWER LH/STA 67.924/								1	1
	96-100016-392	. ZEE,LEADING EDGE LOWER RH/STA 67.924/								1	1
- 64	96-100016-359	. ZEE,LEADING EDGE LOWER LH/STA 65.674/								1	1
	96-100016-360	. ZEE,LEADING EDGE LOWER RH/STA 65.674/								1	1
- 65	96-100016-339	. FORMER,LEADING EDGE LOWER/STA 61.924/								1	1
	96-100016-340	. FORMER,LEADING EDGE LOWER/STA 61.924/								1	1
- 66	96-100016-387	. DOUBLER,LOWER LH/STA 56 TO 68/								1	1
	96-100016-388	. DOUBLER,LOWER RH/STA 56 TO 68/								1	1
- 67	96-100016-347	. FORMER,LEADING EDGE LOWER LH/STA 55.924/								1	1
	96-100016-348	. FORMER,LEADING EDGE LOWER RH/STA 55.924/								1	1
- 68	96-100016-345	. DOUBLER,LOWER LH/STA 55.924/								1	1
	96-100016-346	. DOUBLER,LOWER RH/STA 55.924/								1	1
- 69	96-100016-175	. DOUBLER,LEADING EDGE LOWER LH/STA 55.924/								1	1
	96-100016-176	. DOUBLER,LEADING EDGE LOWER RH/STA 55.924/								1	1
	MK4000-08	. NUTPLATE.								4	1

BEECHCRAFT
DUKE B60
ILLUSTRATED PARTS CATALOG

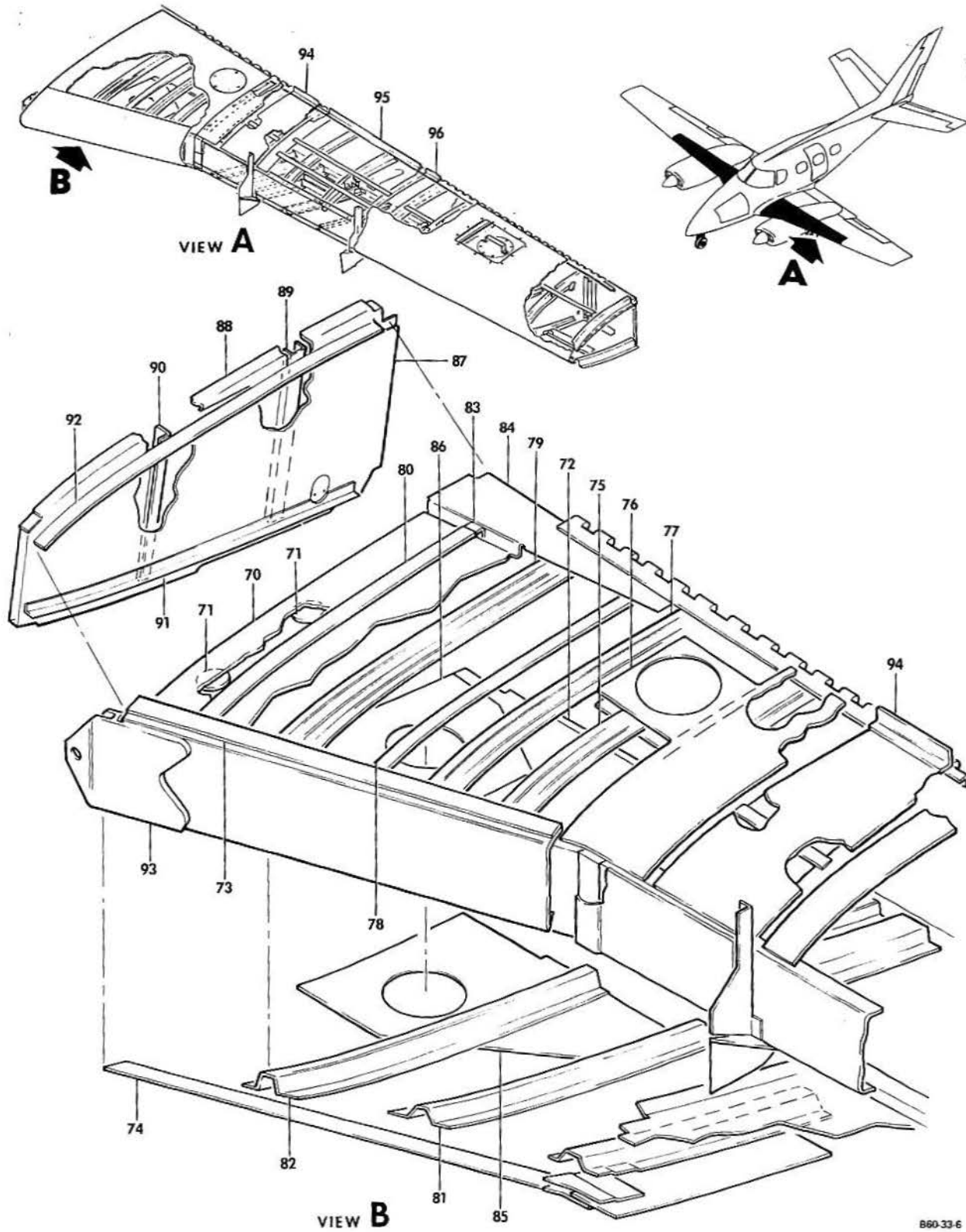

880-33-6

B E E C H C R A F T
DUKE B60
I L L U S T R A T E D P A R T S C A T A L O G

GAMA/ATA CODE & INDEX NO.	PART NO.	DESCRIPTION	UNITS PER ASSY	USABLE ON CODE		
					1	2
20-02	96-100016-405	. LINER ASSY,FUEL CELL UPPER LH	1	1		
	96-100016-406	. LINER ASSY,FUEL CELL UPPER RH	1	1		
- 70	96-100016-417	. . LINER,UPPER LH/STA 32.805 TO STA 55.924/. . .	1	1		
	96-100016-418	. . LINER,UPPER RH/STA 32.805 TO STA 55.924/. . .	1	1		
- 71	000-110172-1	. . RETAINER,FUEL CELL SUPPORT.	6	1		
- 72	96-100016-407	. LINER,FUEL CELL LOWER LH/STA 32.8 TO 55.9/. . .	1	1		
	96-100016-408	. LINER,FUEL CELL LOWER RH/STA 32.8 TO 55.9/. . .	1	1		
- 73	96-100016-191	. SHIM,SKIN LEADING EDGE UPPER LH & RH.	1	1		
- 74	96-100016-193	. SHIM,SKIN LEADING EDGE LOWER LH & RH.	1	1		
- 75	96-100016-141	. FORMER,LEADING EDGE UPPER LH/STA 51.954/. . .	1	1		
	96-100016-142	. FORMER,LEADING EDGE UPPER RH/STA 51.954/. . .	1	1		
- 76	96-100016-143	. ANGLE,LEADING EDGE UPPER LH & RH.	1	1		
	96-100016-145	. CLIP,ANGLE OUTBOARD	1	1		
	96-100016-146	. CLIP,ANGLE INBOARD.	1	1		
- 77	96-100016-185	. FORMER,LEADING EDGE UPPER LH/STA 48.299/. . .	1	1		
	96-100016-186	. FORMER,LEADING EDGE UPPER RH/STA 48.299/. . .	1	1		
- 78	96-100016-147	. ZEE,LEADING EDGE UPPER LH/STA 44.484/.	1	1		
	96-100016-148	. ZEE,LEADING EDGE UPPER RH/STA 44.484/.	1	1		
- 79	96-100016-181	. FORMER,LEADING EDGE UPPER LH/STA 40.674/. . .	1	1		
	60-110012-59	. FORMER,LEADING EDGE UPPER RH/STA 40.674/. . .	1	1		
- 80	96-100016-151	. ZEE,LEADING EDGE UPPER LH	1	1		
	96-100016-152	. ZEE,LEADING EDGE UPPER RH	1	1		
- 81	96-100016-183	. FORMER,LEADING EDGE LOWER LH/STA 48.299/. . .	1	1		
	96-100016-184	. FORMER,LEADING EDGE LOWER RH/STA 48.299/. . .	1	1		
- 82	96-100016-3	. FORMER,LEADING EDGE LOWER LH/STA 40.674/. . .	1	1		
	96-100016-4	. FORMER,LEADING EDGE LOWER RH/STA 40.674/. . .	1	1		
- 83	96-100016-149	. CLIP,UPPER GUSSET	1	1		
- 84	50-110056-2	. GUSSET,LEADING EDGE UPPER LH.	1	1		
	50-110056-3	. GUSSET,LEADING EDGE UPPER RH.	1	1		
- 85	60-110013-3	. GUSSET,LEADING EDGE LOWER LH.	1	1		
	60-110013-4	. GUSSET,LEADING EDGE LOWER RH.	1	1		
- 86	60-921011-1	. BRACKET,LEADING EDGE BOOST PUMP MOUNTING LH .	1	1		
	60-921011-2	. BRACKET,LEADING EDGE BOOST PUMP MOUNTING RH .	1	1		
	R 130909N33	. NUTPLATE.	8	1		
	60-110018-605	. RIB ASSY,LEADING EDGE LH INBD/STA 32.805/ . . .	1	1		
	60-110018-606	. RIB ASSY,LEADING EDGE RH INBD/STA 32.805/ . . .	1	1		
- 87	60-110018-19	. . RIB,ROOT LH	1	1		
	60-110018-20	. . RIB,ROOT RH	1	1		
	60-110018-21	. . REINFORCEMENT,ROOT RIB LH	1	1		
	60-110018-22	. . REINFORCEMENT,ROOT RIB RH	1	1		
- 88	50-110046-8	. . ANGLE,ROOT RIB LH	1	1		
	50-110046-9	. . ANGLE,ROOT RIB RH	1	1		
- 89	50-110010-165	. . STIFFENER,ROOT RIB AFT.	1	1		
- 90	60-110018-7	. . STIFFENER,ROOT RIB FWD.	1	1		
	AN931-3-5	. . GROMMET	1	1		
- 91	60-110018-11	. ANGLE,ROOT RIB LOWER LH	1	1		
	60-110018-12	. ANGLE,ROOT RIB LOWER RH	1	1		
- 92	60-110018-13	. ANGLE,ROOT RIB UPPER LH	1	1		
	60-110018-14	. ANGLE,ROOT RIB UPPER RH	1	1		
- 93	60-110021-1	. SUPPORT,LH LEADING EDGE SHEAR TIE	1	1		
	60-110021-2	. SUPPORT,RH LEADING EDGE SHEAR TIE	1	1		
- 94	60-980000-21	. ANGLE,LH NACELLE SUPPORT/STA 69.264/.	1	1		
	60-980000-22	. ANGLE,RH NACELLE SUPPORT/STA 69.264/.	1	1		
- 95	60-980000-67	. ANGLE,LH NACELLE SUPPORT/STA 79.264/.	1	1		
	60-980000-68	. ANGLE,RH NACELLE SUPPORT/STA 79.264/.	1	1		
- 96	60-980000-139	. ANGLE,LH NACELLE SUPPORT/STA 89.264/.	1	1		
	60-980000-140	. ANGLE,RH NACELLE SUPPORT/STA 89.264/.	1	1		

BEECHCRAFT
DUKE B60
ILLUSTRATED PARTS CATALOG

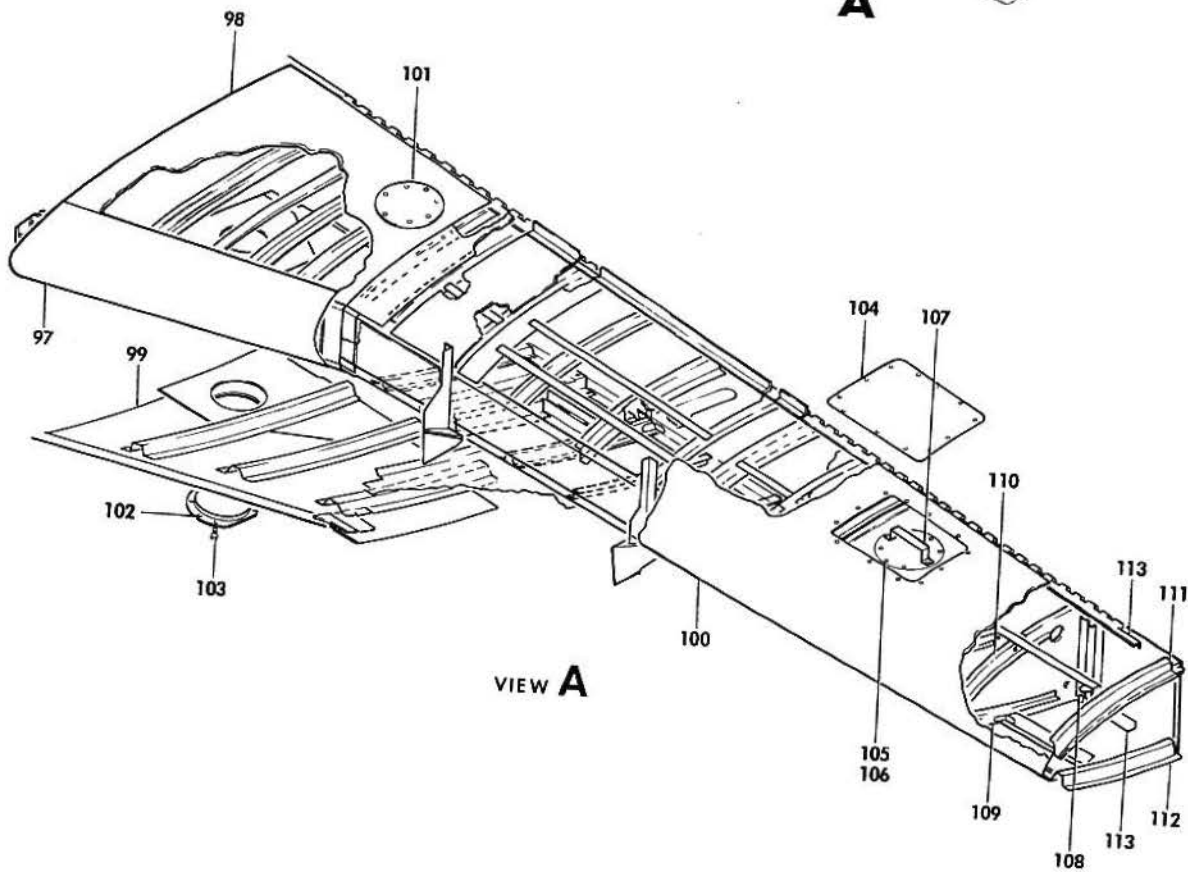
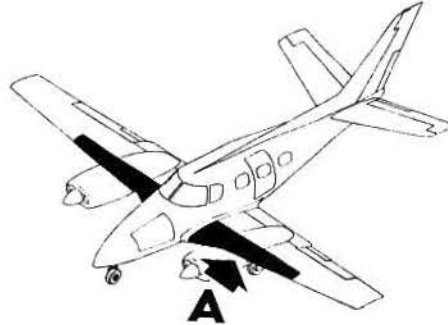

860-33-7

B E E C H C R A F T
DUKE B60
I L L U S T R A T E D P A R T S C A T A L O G

GAMA/ATA CODE & INDEX NO.	PART NO.	DESCRIPTION							UNITS PER ASSY	USABLE ON CODE
		1	2	3	4	5	6	7		
20-02	60-540018	• SUPPORT,PRESURIZATION DUCT.							3	1
		/ATTACHING PARTS/								
	AN515-8R14	• SCREW							1	
	AN515-8R26	• SCREW							1	
- 97	60-110012-53	• SKIN,INBD LEADING EDGE LH/STA 32.8 TO 55.9/ .							1	1
	60-110012-54	• SKIN,INBD LEADING EDGE RH/STA 32.8 TO 55.9/ .							1	1
		/ATTACHING PARTS/								
	AN509-832-8	• SCREW							29	
	NAS697A08	• NUTPLATE.							29	
- 98	60-110012-55	• SKIN,INBD LEADING EDGE UPPER LH							1	1
	60-110012-56	• SKIN,INBD LEADING EDGE UPPER RH							1	1
- 99	60-110012-57	• SKIN,INBD LEADING EDGE LOWER LH							1	1
	60-110012-58	• SKIN,INBD LEADING EDGE LOWER RH							1	1
-100	96-100016-367	• SKIN,LEADING EDGE LH/STA 55.9 TO 131.67/ .							1	1
	96-100016-368	• SKIN,LEADING EDGE RH/STA 55.9 TO 131.67/ .							1	1
-101	60-110032	COVER,FUEL TRANSMITTER ACCESS							1	1
		/ATTACHING PARTS/								
	AN507-632-8	SCREW							6	
	MS21047L08	NUTPLATE.							6	
-102	R 000-110240-1	DOOR,FUEL BOOST PUMP ACCESS/LH/							1	1
	R 000-110240-2	DOOR,FUEL BOOST PUMP ACCESS/RH/							1	1
		/ATTACHING PARTS/								
-103	AN509-10R7	SCREW							8	
-104	MS35489-2S	GROMMET,BOOST PUMP ACCESS DOOR.							1	1
	96-100016-113	DOOR ASSY,FUEL CELL ACCESS LH							1	1
	96-100016-114	DOOR ASSY,FUEL CELL ACCESS RH							1	1
		/ATTACHING PARTS/								
	AN509-8R8	SCREW							12	
	MS21047-08K	NUTPLATE.							12	
-105	60-921025	PLATE ASSY,FUEL CELL ACCESS CLOSURE							1	1
		/ATTACHING PARTS/								
	MS20073-04-07	BOLT.							12	
	AN960-416L	WASHER.							12	
-106	35-921502-1	GASKET,FUEL CELL ACCESS PLATE							1	1
-107	69-921027-1	BRACKET ASSY,FUEL CELL ACCESS COVER MOUNTING. .							1	1
-108	000-110107-3	ZEE,LH RIB/STA 122.096/							1	1
	000-110107-4	ZEE,RH RIB/STA 122.096/							1	1
-109	000-110107-7	ANGLE,LINER SUPPORT LOWER LH.							1	1
	000-110107-8	ANGLE,LINER SUPPORT LOWER RH.							1	1
-110	000-110107-9	ANGLE,LINER SUPPORT UPPER LH.							1	1
	000-110107-10	ANGLE,LINER SUPPORT UPPER RH.							1	1
-111	000-110135-29	FORMER,UPPER LH/STA 131.674/							1	1
	000-110135-30	FORMER,UPPER RH/STA 131.674/							1	1
-112	000-110135-31	FORMER,LOWER LH/STA 131.674/							1	1
	000-110135-32	FORMER,LOWER,RH/STA 131.674/							1	1
-113	000-110161-7	ANGLE,HINGE SPLICE UPPER & LOWER.							2	1

CODES OF EFFECTIVITY

1 P-267 AND AFTER

BEECHCRAFT
DUKE 860
ILLUSTRATED PARTS CATALOG

57-20-10
WING OUTBOARD LEADING EDGE
P-247 THRU P-266

BEECHCRAFT
DUKE B60
ILLUSTRATED PARTS CATALOG

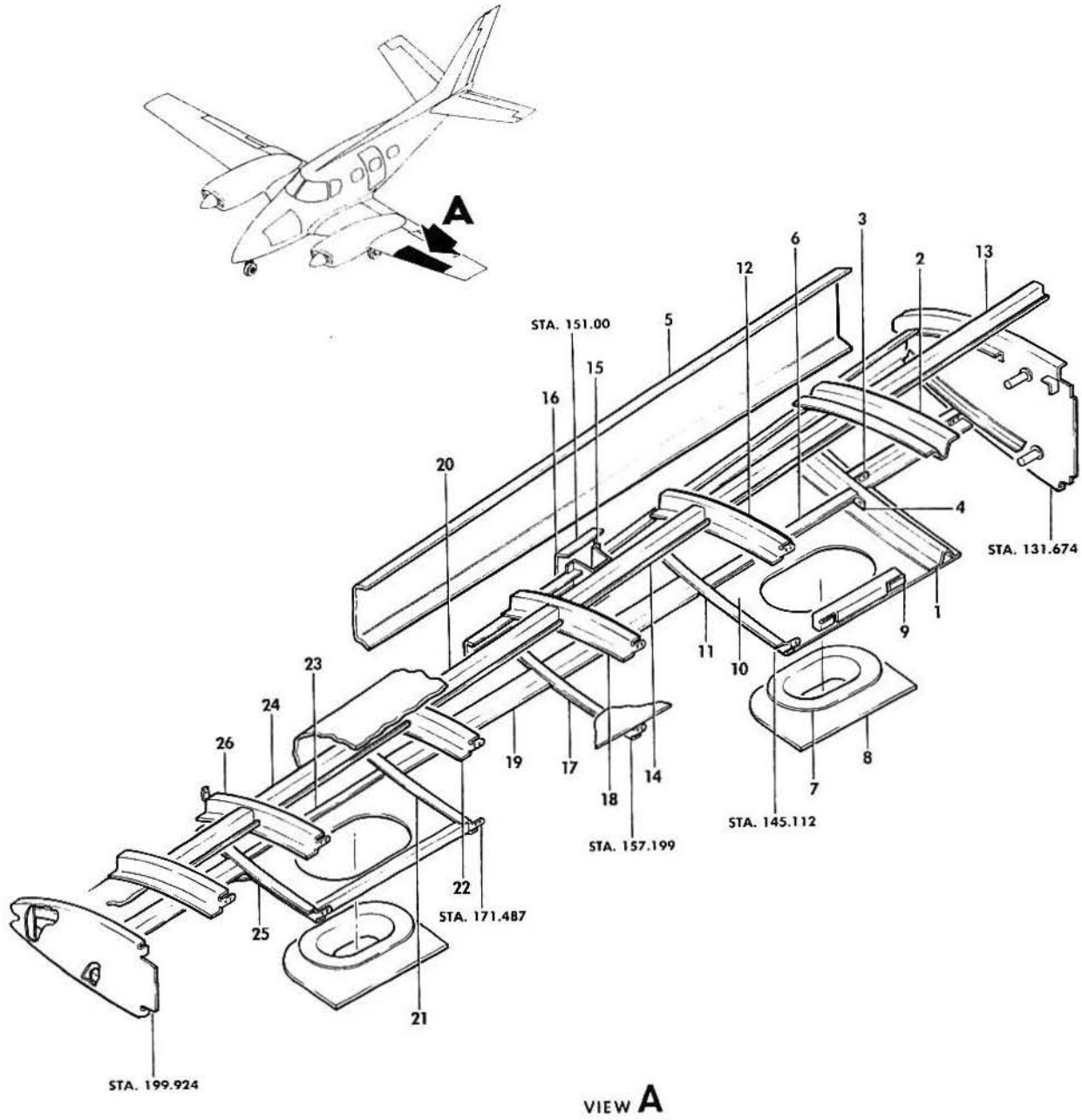

B60-34-5

B E E C H C R A F T
DUKE B60
I L L U S T R A T E D P A R T S C A T A L O G

GAMA/ATA CODE & INDEX NO.	PART NO.	DESCRIPTION	1 2 3 4 5 6 7							UNITS PER ASSY	USABLE ON CODE
			1	2	3	4	5	6	7		
20-10	96-100016-621	LEADING EDGE ASSY,OUTBOARD WING LH.	1	1
	96-100016-622	LEADING EDGE ASSY,OUTBOARD WING RH.	1	1
- 1	96-100016-231	. HAT SECTION,LH LOWER.	1	1
	96-100016-232	. HAT SECTION,RH LOWER.	1	1
- 2	96-100016-233	. HAT SECTION,LH UPPER.	1	1
	96-100016-234	. HAT SECTION,RH UPPER.	1	1
- 3	96-100016-317	. CLIP,LH	2	1
	96-100016-318	. CLIP,RH	2	1
- 4	96-100016-319	. CLIP,LH	2	1
	96-100016-320	. CLIP,RH	2	1
- 5	96-100016-289	. WEB,LH/STA 122 TO 199/.	1	1
	96-100016-290	. WEB,RH/STA 121 TO 199/.	1	1
- 6	96-100016-265	. ZEE,LH LOWER.	1	1
	96-100016-266	. ZEE,RH LOWER.	1	1
	96-100016-395	. DOOR ASSY,INBD LINER ACCESS	1	1
- 7	96-100016-307	. . PAN,DOOR.	1	1
- 8	96-100016-397	. . DOOR.	1	1
- 9	96-100016-327	. BRACKET,INBD LINER DOOR	1	1
	96-100016-637	. DOUBLER ASSY,LH INBD LINER DOOR	1	1
	96-100016-638	. DOUBLER ASSY,RH INBD LINER DOOR	1	1
- 10	96-100016-401	. . DOUBLER,LH.	1	1
	96-100016-402	. . DOUBLER,RH.	1	1
	MS21048-08K	. . NUTPLATE.	13	1
- 11	96-100016-235	. ZEE,LH LOWER/STA 145.112/	1	1
	96-100016-236	. ZEE,RH LOWER/STA 145.112/	1	1
- 12	96-100016-237	. ZEE,LH UPPER/STA 145.112/	1	1
	96-100016-238	. ZEE,RH UPPER/STA 145.112/	1	1
- 13	96-100016-277	. STRINGER,LH UPPER/STA 131 TO 145/	1	1
	96-100016-278	. STRINGER,RH UPPER/STA 131 TO 145/	1	1
- 14	96-100016-283	. STRINGER,LH UPPER & LOWER/STA 145 TO 157/	2	1
	96-100016-284	. STRINGER RH UPPER & LOWER/STA 145 TO 157/	2	1
	96-100016-321	. CLIP,STRINGER TO ZEE.	16	1
	96-100016-323	. CLIP,STRINGER TO ZEE.	3	1
	96-100016-325	. CLIP,STRINGER TO ZEE.	3	1
- 15	96-100016-351	. HAT SECTION,LH/STA 151.830/	1	1
- 16	96-100016-313	. DOUBLER,BRACKET	1	1
	151-101-3	. DOUBLER,STALL WARNING DETECTOR.	1	1
- 17	96-100016-239	. ZEE,LH LOWER/STA 157.799/	1	1
	96-100016-240	. ZEE,RH LOWER/STA 157.799/	1	1
- 18	96-100016-241	. ZEE,LH UPPER/STA 157.799/	1	1
	96-100016-242	. ZEE,RH UPPER/STA 157.799/	1	1
- 19	96-100016-269	. STRINGER,LH LOWER/STA 157 TO 171/	1	1
	96-100016-270	. STRINGER,RH LOWER/STA 157 TO 171/	1	1
- 20	96-100016-281	. STRINGER,LH UPPER/STA 157 TO 171/	1	1
	96-100016-282	. STRINGER,RH UPPER/STA 157 TO 171/	1	1
- 21	96-100016-243	. ZEE,LH LOWER/STA 171.487/	1	1
	96-100016-244	. ZEE,RH LOWER/STA 171.487/	1	1
- 22	96-100016-245	. ZEE,LH UPPER/STA 171.487/	1	1
	96-100016-246	. ZEE,RH UPPER/STA 171.487/	1	1
- 23	96-100016-271	. ZEE,LH LOWER/STA 171 TO 184/.	1	1
	96-100016-272	. ZEE,RH LOWER/STA 171 TO 184/.	1	1
- 24	96-100016-283	. STRINGER,LH UPPER/STA 171 TO 184/	1	1
	96-100016-284	. STRINGER,RH UPPER/STA 171 TO 184/	1	1
- 25	96-100016-247	. ZEE,LH LOWER/STA 184.205/	1	1
	96-100016-248	. ZEE,RH LOWER/STA 184.205/	1	1
- 26	96-100016-249	. ZEE,LH UPPER/STA 184.205/	1	1
	96-100016-250	. ZEE,RH UPPER/STA 184.205/	1	1

BEECHCRAFT
DUKE B60
ILLUSTRATED PARTS CATALOG

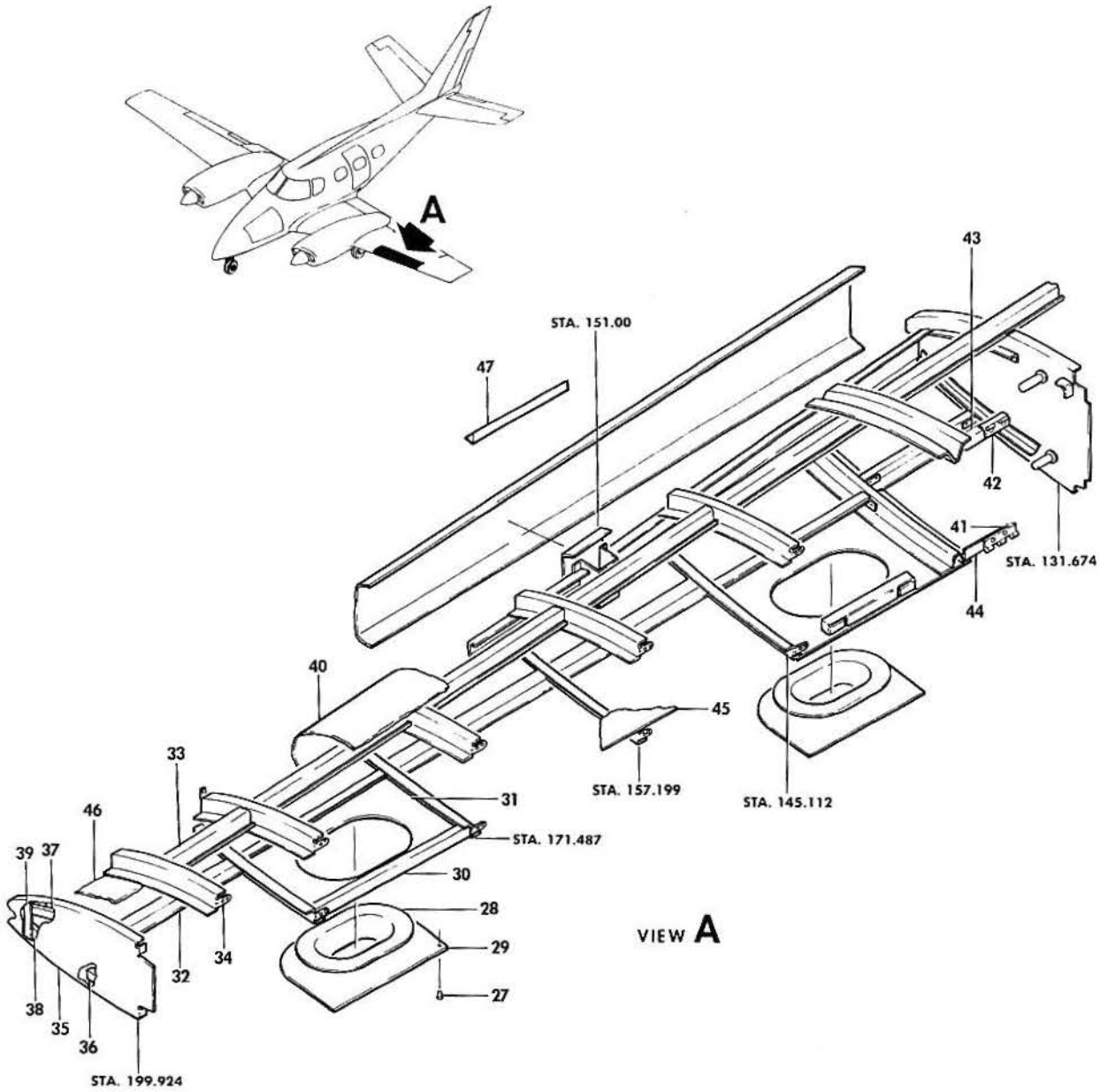

B60-34-6

B E E C H C R A F T
DUKE B60
I L L U S T R A T E D P A R T S C A T A L O G

GAMA/ATA CODE & INDEX NO.	PART NO.	DESCRIPTION	UNITS PER ASSY	USABLE ON CODE
		1 2 3 4 5 6 7		
20-10	96-100016-305	• DOOR ASSY,OUTBOARD LINER ACCESS	1	1
		/ATTACHING PARTS/		
- 27	MS24693S50	• SCREW	20	
		-----*		
- 28	96-100016-307	• PAN,DOOR.	1	1
- 29	96-100016-311	• DOOR.	1	1
- 30	96-100016-329	• ANGLE,OUTBOARD LINER DOOR	1	1
	96-100016-635	• DOUBLER ASSY,LH OUTBOARD LINER DOOR	1	1
	96-100016-636	• DOUBLER ASSY,RH OUTBOARD LINER DOOR	1	1
- 31	96-100016-301	• DOUBLER,LH.	1	1
	96-100016-302	• DOUBLER,RH.	1	1
	NAS697C08M	• NUTPLATE.	13	1
	NAS681C08M	• NUTPLATE.	17	1
	MS35489-4	• GROMMET	6	1
- 32	96-100016-273	• STRINGER,LH LOWER/STA 184 TO 199/	1	1
	96-100016-274	• STRINGER,RH LOWER/STA 184 TO 199/	1	1
- 33	96-100016-285	• STRINGER,LH UPPER/STA 184 TO 192.05/	1	1
	96-100016-286	• STRINGER,RH UPPER/STA 184 TO 192.05/	1	1
- 34	96-100016-251	• ZEE,LH UPPER/STA 192.054/	1	1
	96-100016-252	• ZEE,RH UPPER/STA 192.054/	1	1
	96-100016-633	• RIB ASSY,LH OUTBOARD/STA 199/	1	1
	96-100016-634	• RIB ASSY,RH OUTBOARD/STA 199/	1	1
- 35	96-100016-255	• RIB,LH.	1	1
	96-100016-256	• RIB,RH.	1	1
- 36	96-100016-257	• ANGLE,LH LOWER.	1	1
	96-100016-258	• ANGLE,RH LOWER.	1	1
- 37	96-100016-259	• ANGLE,LH UPPER.	1	1
	96-100016-260	• ANGLE,RH UPPER.	1	1
- 38	96-100016-349	• ANGLE,LH LOWER.	1	1
	96-100016-350	• ANGLE,RH LOWER.	1	1
- 39	96-100016-261	• BRACKET,FWD	1	1
	MK2000-06	• NUTPLATE.	6	1
	NAS682A08	• NUTPLATE.	1	1
	MS21059L08K	• NUTPLATE.	7	1
- 40	96-100016-399	• SKIN,LH OUTBOARD.	1	1
	96-100016-400	• SKIN,RH OUTBOARD.	1	1
- 41	96-100016-361	• HINGE,LH LEADING EDGE OUTBD LOWER HALF.	1	1
	96-100016-362	• HINGE,RH LEADING EDGE OUTBD LOWER HALF.	1	1
- 42	96-100016-375	• HINGE,LH LEADING EDGE OUTBD UPPER HALF.	1	1
	96-100016-376	• HINGE,RH LEADING EDGE OUTBD UPPER HALF.	1	1
	105774CZG18700	PIN,HINGE UPPER & LOWER	2	2
	105774CZG17004	PIN,HINGE UPPER & LOWER	2	3
- 43	96-100016-363	SPLICE,UPPER LH HINGE	1	1
	96-100016-364	SPLICE,UPPER RH HINGE	1	1
- 44	96-100016-365	SPLICE,LOWER LH HINGE	1	1
	96-100016-366	SPLICE,LOWER RH HINGE	1	1
	96-100016-369	CLIP,LH	2	1
	96-100016-370	CLIP,RH	2	1
	96-100016-371	CLIP,LH	1	1
	96-100016-370	CLIP,RH	1	1
- 45	96-100016-411	LINER,LH LOWER FUEL CELL.	1	1
	96-100016-412	LINER,RH LOWER FUEL CELL.	1	1
- 46	96-100016-419	LINER ASSY,LH UPPER FUEL CELL	1	1
	96-100016-420	LINER ASSY,RH UPPER FUEL CELL	1	1
- 47	60-110012-65	STALL STRIP,LH/WITHOUT DEICE/	1	1
	60-110012-67	STALL STRIP,RH/WITHOUT DEICE/	1	1
	130421-01050	STALL STRIP,LH/WITH DEICE BOOT ONLY/.	1	1
	130421-00762	STALL STRIP,RH/WITH DEICE BOOT ONLY/.	1	1

CODES OF EFFECTIVITY

1 P-247 THRU P-266 2 P-247 THRU P-249
3 P-250 THRU P-266

BEECHCRAFT
DUKE B60
ILLUSTRATED PARTS CATALOG

57-20-11
WING OUTBOARD LEADING EDGE
P-267 AND AFTER

BEECHCRAFT
DUKE B60
ILLUSTRATED PARTS CATALOG

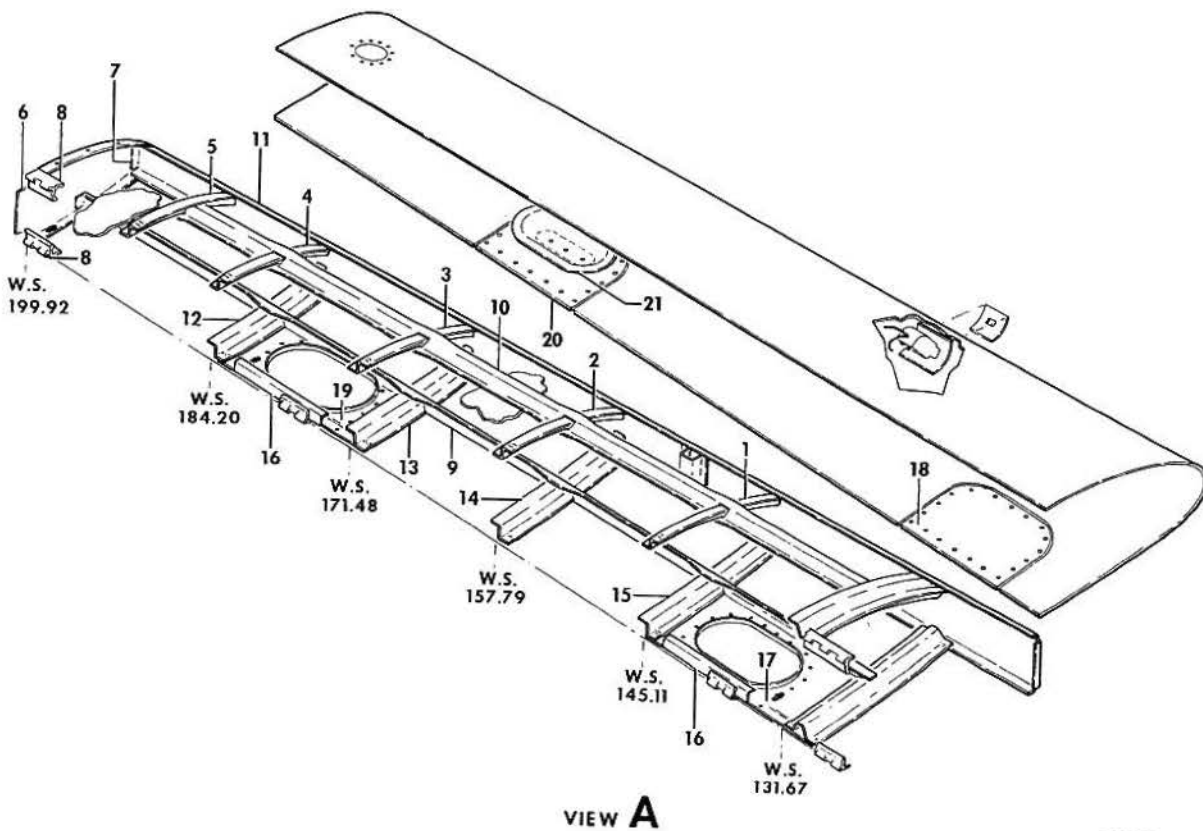
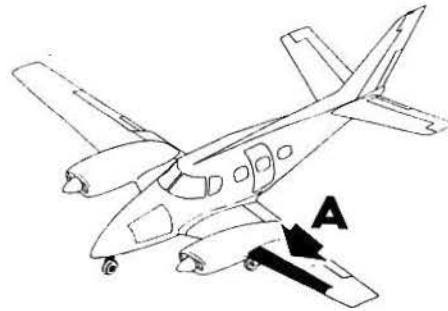

B60-34-3

B E E C H C R A F T
DUKE B60
I L L U S T R A T E D P A R T S C A T A L O G

GAMA/ATA CODE & INDEX NO.	PART NO.	DESCRIPTION	1 2 3 4 5 6 7							UNITS PER ASSY	USABLE ON CODE
			1	2	3	4	5	6	7		
20-11	000-110029-609	LEADING EDGE ASSY,OUTBOARD WING LH.	1	2
	000-110029-59	LEADING EDGE ASSY,LH WING/OUTBD/	1	3
	000-110029-610	LEADING EDGE ASSY,OUTBOARD WING RH.	1	2
	000-110029-60	LEADING EDGE ASSY,RH WING/OUTBD/	1	3
- 1	000-110029-5	. FORMER,UPPER LH/STA 145.112/.	1	1
	000-110029-6	. FORMER,UPPER RH/STA 145.112/.	1	1
- 2	000-110029-7	. FORMER,UPPER LH/STA 157.799/.	1	1
	000-110029-8	. FORMER,UPPER RH/STA 157.799/.	1	1
- 3	000-110029-9	. FORMER,UPPER LH/STA 171.487/.	1	1
	000-110029-10	. FORMER,UPPER RH/STA 171.487/.	1	1
- 4	000-110029-11	. FORMER,UPPER LH/STA 184.205/.	1	1
	000-110029-12	. FORMER,UPPER RH/STA 184.205/.	1	1
- 5	000-110029-13	. FORMER,UPPER LH/STA 192.054/.	1	1
	000-110029-14	. FORMER,UPPER RH/STA 192.054/.	1	1
- 6	000-110096-3	. RIB ASSY,LH/STA 199.924/.	1	1
	000-110096-4	. RIB ASSY,RH/STA 199.924/.	1	1
	000-110096-1	. . RIB,LH.	1	1
	000-110096-2	. . RIB,RH.	1	1
- 7	000-110029-47	. ANGLE,RIB	1	1
- 8	000-110083-3	. HINGE,HALF OUTBOARD UPPER & LOWER	2	1
- 9	000-110029-17	. STRINGER,LOWER LH	1	1
	000-110029-18	. STRINGER,LOWER RH	1	1
- 10	000-110029-19	. STRINGER,UPPER LH	1	1
	000-110029-20	. STRINGER,UPPER RH	1	1
- 11	000-110029-15	. SPAR,OUTBOARD LEADING EDGE LH	1	1
	000-110029-55	. SPAR,OUTBOARD LEADING EDGE RH	1	1
- 12	000-110029-25	. FORMER,LOWER LH/STA 184.205/.	1	1
	000-110029-26	. FORMER,LOWER RH/STA 184.205/.	1	1
- 13	000-110029-27	. FORMER,LOWER LH/STA 171.487/.	1	1
	000-110029-28	. FORMER,LOWER RH/STA 171.487/.	1	1
- 14	000-110029-29	. FORMER,LOWER LH/STA 157.799/.	1	1
	000-110029-30	. FORMER,LOWER RH/STA 157.799/.	1	1
- 15	000-110029-31	. FORMER,LOWER LH/STA 145.112/.	1	1
	000-110029-32	. FORMER,LOWER RH/STA 145.112/.	1	1
- 16	000-110029-33	. ANGLE,LINER SUPPORT	2	1
	000-110029-21	. REINFORCEMENT ASSY,LH	1	1
	000-110029-22	. REINFORCEMENT ASSY,RH	1	1
- 17	000-110029-41	. . REINFORCEMENT,INBD LINER DOOR ACCESS LH	1	1
	000-110029-42	. . REINFORCEMENT,INBD LINER DOOR ACCESS RH	1	1
	MS21049L08	. . NUTPLATE	4	1
	MS21059L08K	. . NUTPLATE	9	1
- 18	000-110029-57	. DOOR,LINER ACCESS	1	1
		/ATTACHING PARTS/									
	AN507B832R8	. SCREW	20	

	000-110029-43	. REINFORCEMENT ASSY,LH	1	
	000-110029-44	. REINFORCEMENT ASSY,RH	1	1
- 19	000-110029-45	. . REINFORCEMENT,OUTBD LINER DOOR ACCESS LH.	1	1
	000-110029-46	. . REINFORCEMENT,OUTBD LINER DOOR ACCESS RH.	1	1
	MS21049L08	. . NUTPLATE	4	1
	MS21059L08K	. . NUTPLATE	9	1
	000-110029-49	. DOOR ASSY,LINER ACCESS.	1	1
		/ATTACHING PARTS/									
	AN507B832R8	. SCREW	20	

- 20	000-110029-35	. . DOOR,ACCESS	1	1
- 21	000-110029-23	. . PAN,DOOR SUPPORT	1	1

BEECHCRAFT
DUKE B60
ILLUSTRATED PARTS CATALOG

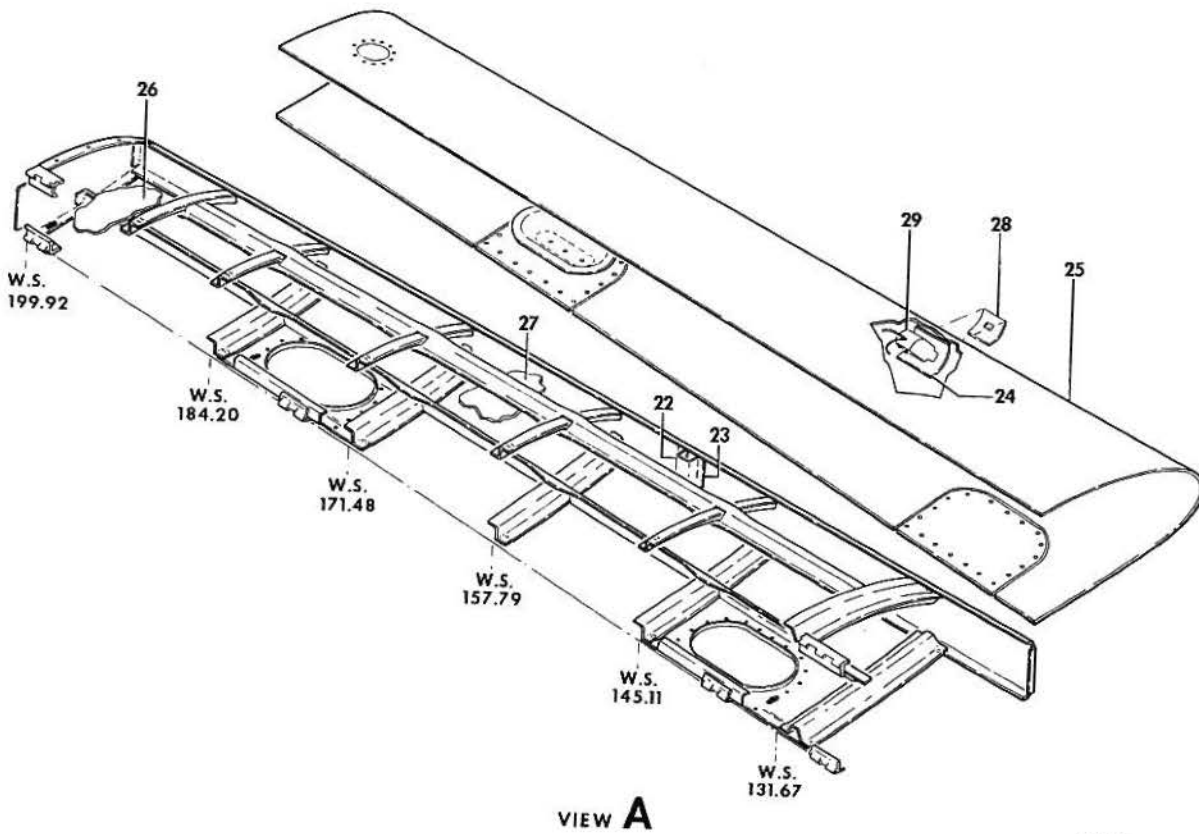
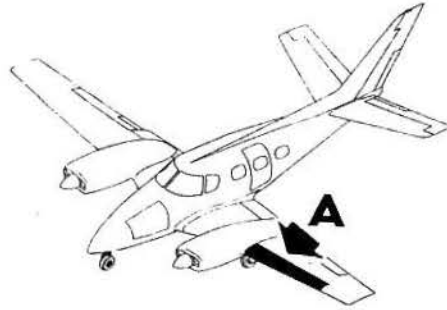

B60-344

BEECHCRAFT
DUKE B60
ILLUSTRATED PARTS CATALOG

GAMA/ATA CODE & INDEX NO.	PART NO.	DESCRIPTION							UNITS PER ASSY	USABLE ON CODE
		1	2	3	4	5	6	7		
20-11	MS21059L08	10	1
	MS21071L08	4	1
	MS35489-4	1	1
- 22	000-110029-51	1	1
- 23	000-110029-37	1	1
- 24	000-110029-39	1	1
- 25	000-110029-3	1	2
	000-110029-67	1	3
	000-110029-53	1	2
	000-110029-69	1	3
- 26	000-110166-1	1	1
	000-110166-3	1	1
- 27	000-110167-1	1	1
	000-110167-5	1	1
	105774CZG17004	2	1
- 28	151-202-1	1	1
- 29	190-3	1	1
	151-202-2	1	1

CODES OF EFFECTIVITY

1	P-267 AND AFTER	2	P-267 THRU P-347 P-349 THRU P-364
3	P-348, P-365 AND AFTER		

B E E C H C R A F T
DUKE B60
I L L U S T R A T E D P A R T S C A T A L O G

57-20-20
WING TRAILING EDGE

BEECHCRAFT
DUKE B60
ILLUSTRATED PARTS CATALOG

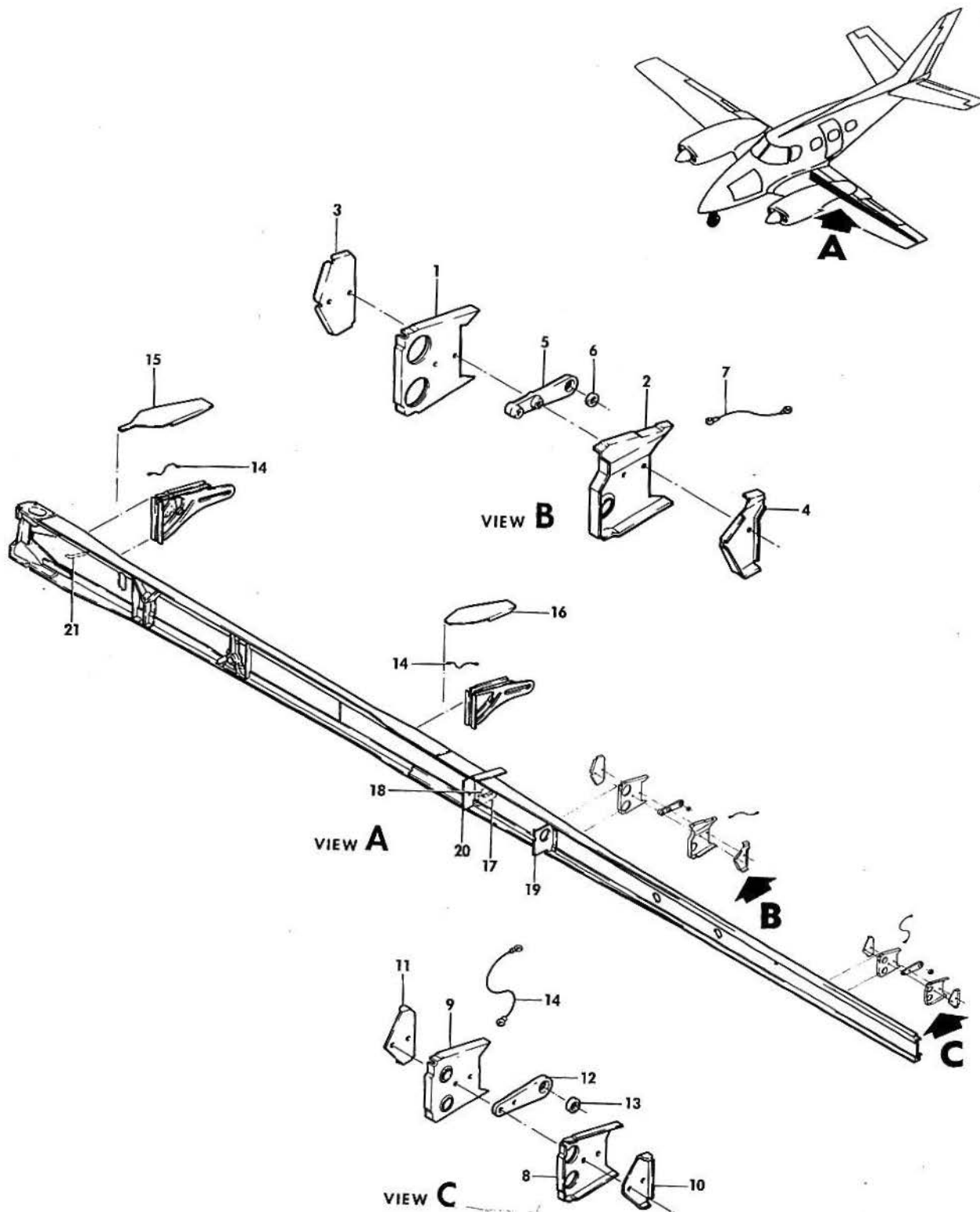

B60-37.4

B E E C H C R A F T
DUKE B60
I L L U S T R A T E D P A R T S C A T A L O G

GAMA/ATA CODE & INDEX NO.	PART NO.	DESCRIPTION	UNITS PER ASSY	USABLE ON CODE		
					1	2
20-20	95-110014-729	REAR SPAR & TRAILING EDGE ASSY,LH WING.	1			
	95-110014-730	REAR SPAR & TRAILING EDGE ASSY,RH WING.	1			
	95-110022-611	. SPAR ASSY,REAR LH/SEE CHAPTER 57-10-30/	1			
	95-110022-614	. SPAR ASSY,REAR RH/SEE CHAPTER 57-10-30/	1			
	95-110022-607	. TRACK ASSY,INBD FLAP LH/SEE CHAPTER 57-10-30/	1			
	95-110022-616	. TRACK ASSY,INBD FLAP RH/SEE CHAPTER 57-10-30/	1			
	95-110022-609	. TRACK ASSY,OUTBD FLAP/SEE CHAPTER 57-10-30/	1			
	95-110022-610	. TRACK ASSY,OUTBD FLAP/SEE CHAPTER 57-10-30/	1			
	95-110014-751	. BRACKET ASSY,INBD AILERON HINGE LH/STA 131.6/	1			
	95-110014-752	. BRACKET ASSY,INBD AILERON HINGE RH/STA 131.6/	1			
- 1	95-110014-111	. . RIB,LH.	1			
	95-110014-112	. . RIB,RH.	1			
- 2	60-130017-3	. . RIB,LH.	1			
	60-130017-4	. . RIB,RH.	1			
- 3	35-115160-16	. . REINFORCEMENT,LH RIB.	1			
	35-115160-17	. . REINFORCEMENT,RH RIB.	1			
- 4	60-130017-5	. . REINFORCEMENT,LH RIB.	1			
	60-130017-6	. . REINFORCEMENT,RH RIB.	1			
	35-115147	. . HINGE ASSY,AILERON INBD	1			
- 5	35-115147-2	. . FITTING,HINGE	1			
- 6	NAS505-3	. . BEARING,NEEDLE.	1			
- 7	MS25083-1AA8	. . JUMPER,BONDING.	1			
		/ATTACHING PARTS/				
	MS35206-230	. . SCREW	1			
	AN960-6L	. . WASHER.	2			
	MS21042L06	. . NUT	1			
		-----*				
	95-110014-637	. BRACKET ASSY,OUTBD AILERON HINGE LH/STA 184/.	1			
	95-110014-638	. BRACKET ASSY,OUTBD AILERON HINGE RH/STA 184/.	1			
- 8	95-110014-31	. . BRACKET,LH.	1			
	95-110014-32	. . BRACKET,RH.	1			
- 9	95-110014-29	. . BRACKET,LH.	1			
	95-110014-30	. . BRACKET,RH.	1			
- 10	35-115071-14	. . ANGLE,LH.	1			
	35-115071-15	. . ANGLE,RH.	1			
- 11	35-115071-16	. . ANGLE,LH.	1			
	35-115071-17	. . ANGLE,RH.	1			
	35-115071-12	. . HINGE ASSY,AILERON OUTBD.	1			
- 12	35-115071-10	. . FITTING,HINGE	1			
- 13	NAS505-3	. . BEARING,NEEDLE.	1			
- 14	MS25083-2AA6	. . JUMPER,BONDING.	1			
		/ATTACHING PARTS/				
	AN515-6R12	. . SCREW	1			
	AN960-62	. . WASHER.	2			
	MS21042L06	. . NUT	1			
		-----*				
	NAS680A06	. NUTPLATE.	2			
	130006A832	. NUTPLATE.	1			
- 15	95-110014-277	. GUSSET,UPPER LH/STA 43/	1			
	95-110014-505	. GUSSET,UPPER RH/STA 43/	1			
- 16	95-110014-279	. GUSSET,UPPER LH/STA 103/.	1			
	95-110014-280	. GUSSET,UPPER RH/STA 103/.	1			
- 17	95-110014-865	. BRACKET,LH/STA 117/	1			
	95-110014-866	. BRACKET,RH/STA 117/	1			
- 18	95-110014-587	. DOUBLER,LH/STA 117/	1			
	95-110014-588	. DOUBLER,RH/STA 117/	1			
- 19	95-110014-929	. DOUBLER,LH/STA 131-6/	1			
	95-110014-930	. DOUBLER,RH/STA 131.6/	1			
- 20	95-110014-857	. COVER,LH/STA 117/	1			
- 21	35-115236	. SUPPORT,LH.	1			
	35-115236	. SUPPORT,RH.	2			

BEECHCRAFT
DUKE B60
ILLUSTRATED PARTS CATALOG

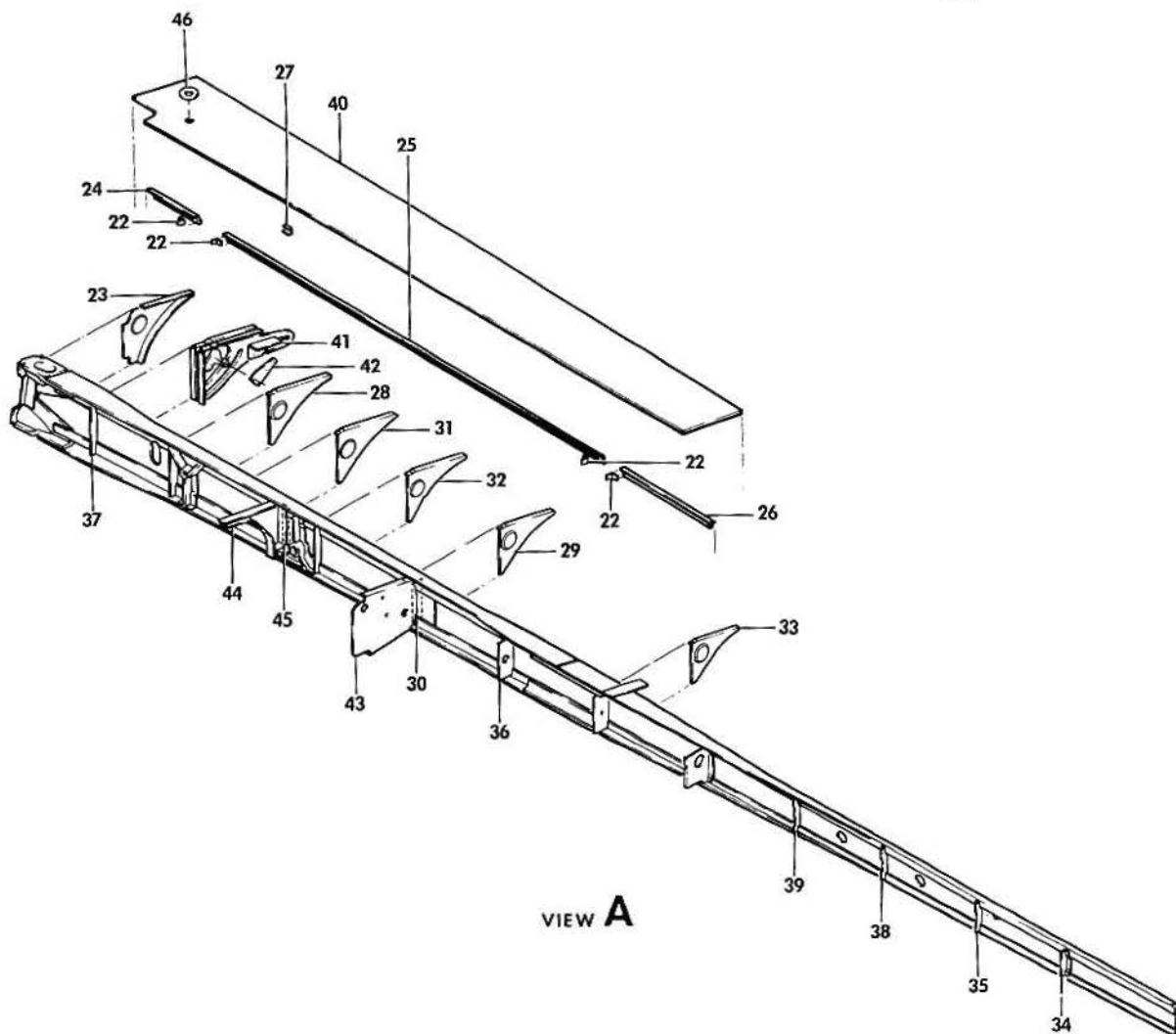
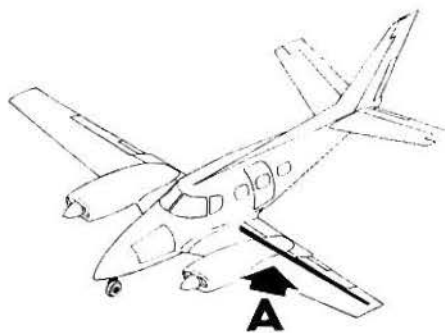

B60-37-5

B E E C H C R A F T
DUKE B60
I L L U S T R A T E D P A R T S C A T A L O G

GAMA/ATA CODE & INDEX NO.	PART NO.	DESCRIPTION	UNITS PER ASSY	USABLE ON CODE		
					1	2
20-20 - 22	95-110014-373	• CLIP	4			
- 23	95-110037	• RIB,LH/STA 32.8/	1			
	95-110037-1	• RIB,RH/STA 32.8/	1			
- 24	95-110014-945	• STRINGER,LH	1			
	95-110014-946	• STRINGER,RH	1			
- 25	95-110014-943	• STRINGER,LH	1			
	95-110014-944	• STRINGER,RH	1			
- 26	95-110014-941	• STRINGER,LH	1			
	95-110014-942	• STRINGER,RH	1			
- 27	35-115301-22	• CHANNEL,LH	1			
	35-115150-1	• SUPPORT,RH	1			
- 28	95-110014-135	• RIB,LH/STA 54/	1			
	95-110014-591	• RIB,RH/STA 54/	1			
- 29	95-110014-191	• RIB,LH/STA 89/	1			
	95-110014-192	• RIB,RH/STA 89/	1			
- 30	95-110014-193	• ANGLE,TRAILING EDGE LH/STA 89/	1			
	95-110014-194	• ANGLE,TRAILING EDGE RH/STA 89/	1			
- 31	95-110014-129	• RIB,LH/STA 64/	1			
	95-110014-130	• RIB,RH/STA 64/	1			
- 32	95-110014-153	• RIB,LH/STA 74.9/	1			
	95-110014-154	• RIB,RH/STA 74.9/	1			
- 33	95-110014-119	• RIB,LH/STA 117/	1			
	95-110014-120	• RIB,RH/STA 117/	1			
- 34	95-110014-37	• ANGLE,MAIN RIB LH/STA 184/	1			
	95-110014-38	• ANGLE,MAIN RIB RH/STA 184/	1			
- 35	95-110014-61	• ANGLE,MAIN RIB LH/STA 171/	1			
	95-110014-62	• ANGLE,MAIN RIB RH/STA 171/	1			
- 36	95-110014-183	• ANGLE,MAIN RIB LH/STA 103/	1			
	95-110014-184	• ANGLE,MAIN RIB RH/STA 103/	1			
- 37	95-110030-11	• ANGLE,MAIN RIB LH/STA 43/	1			
	95-110039-5	• ANGLE,MAIN RIB RH/STA 43/	1			
- 38	95-110014-73	• ANGLE,MAIN RIB LH/STA 157/	1			
	95-110014-74	• ANGLE,MAIN RIB RH/STA 157/	1			
- 39	95-110014-89	• ANGLE,MAIN RIB LH/STA 145/	1			
	95-110014-90	• ANGLE,MAIN RIB RH/STA 145/	1			
- 40	95-110014-761	• SKIN ASSY,TRAILING EDGE INBD LH	1			
	95-110014-768	• SKIN ASSY,TRAILING EDGE INBD RH	1			
- 41	60-369000-95	• BRACKET,FLAP LIMIT SWITCH/LH ONLY/	1			
	60-369000-97	• DOUBLER,FLAP LIMIT SWITCH BRACKET	1			
- 42	96-361011-13	• BRACKET,FLAP 15 DEGREE SWITCH/LH ONLY/	1			
		/ATTACHING PARTS/				
	MS35206-244	• SCREW	3			
	AN960-8	• WASHER	3			
- 43	60-980029-1	• TIE,SPAR OUTBOARD LH	1			
	60-980029-2	• TIE,SPAR OUTBOARD RH	1			
- 44	60-980047-3	• TIE,SPAR INBD LH	1			
	60-980047-4	• TIE,SPAR INBD RH	1			
	95-980001-113	• FILLER,INBD TIE	1			
- 45	60-980000-297	• PLATE,INBD TIE	1			
- 46	60-530222-1	RECEPTACLE,CABIN DOOR STAY/STA 39.73/	1			

BEECHCRAFT
DUKE 860
ILLUSTRATED PARTS CATALOG

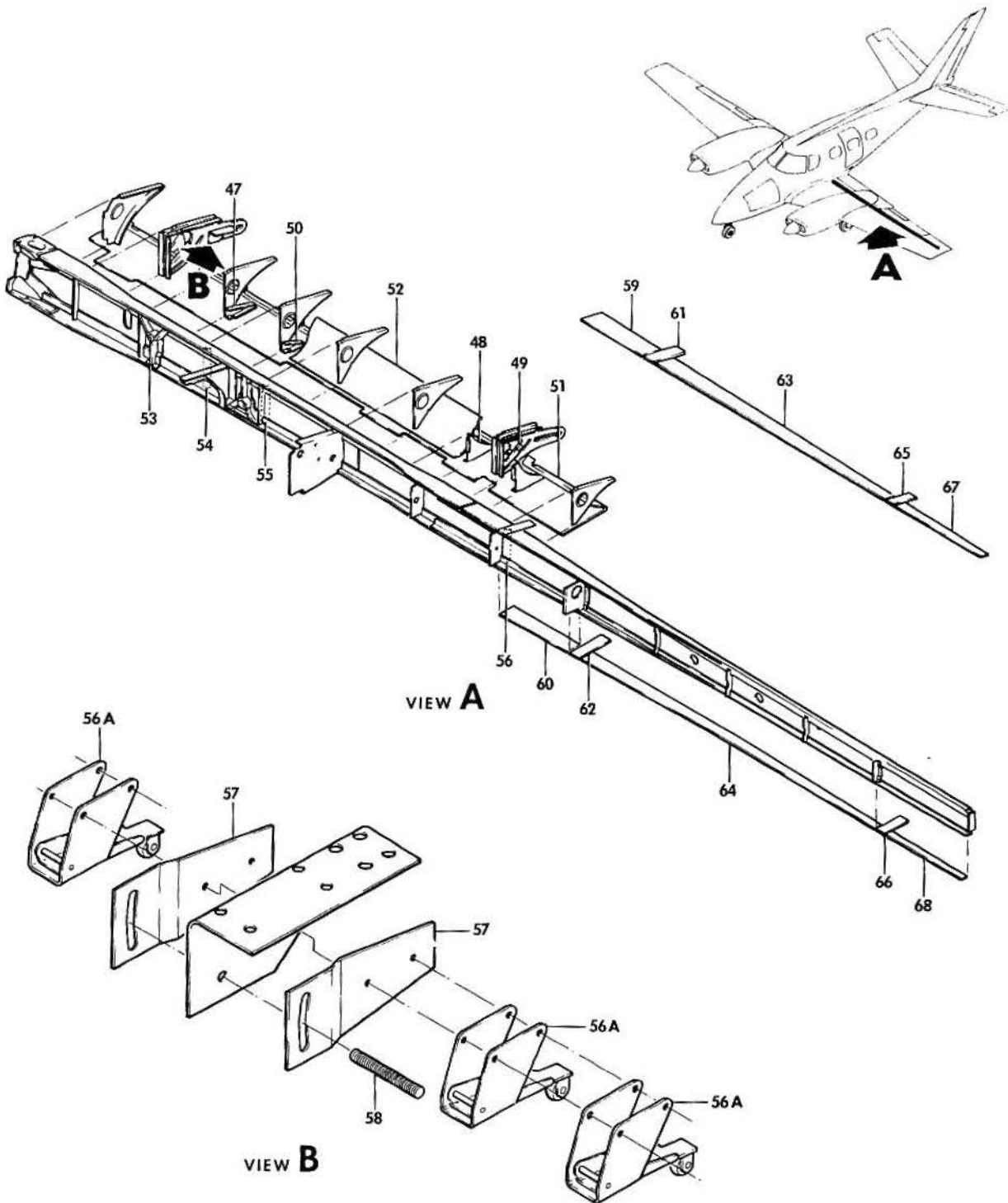

B60-37-6

B E E C H C R A F T
DUKE B60
I L L U S T R A T E D P A R T S C A T A L O G

GAMA/ATA CODE & INDEX NO.	PART NO.	DESCRIPTION	UNITS PER ASSY	USABLE ON CODE		
					1	2
20-20	95-110014-759	SKIN ASSY,LH TRAILING EDGE INBD	1			
	95-110014-760	SKIN ASSY,RH TRAILING EDGE INBD	1			
- 47	95-110014-301	. FORMER,TRAILING EDGE/STA 54/.	1			
- 48	95-110014-315	. RIB,LH TRAILING EDGE/STA 98/.	1			
	95-110014-316	. RIB,RH TRAILING EDGE/STA 98/.	1			
- 49	95-110014-317	. RIB,LH TRAILING EDGE/STA 109/.	1			
	95-110014-318	. RIB,RH TRAILING EDGE/STA 109/.	1			
- 50	95-110014-533	. FORMER,LH TRAILING/STA 59/.	1			
	95-110014-534	. FORMER,RH TRAILING EDGE/STA 59/.	1			
	35-115265-8	. CLIP,LH/STA 44/.	1			
- 51	95-110014-869	. SKIN,LH LOWER TRAILING EDGE	1			
	95-110014-870	. SKIN,RH LOWER TRAILING EDGE	1			
- 52	95-110014-535	. SKIN,LH TRAILING EDGE FAIRING	1			
	95-110014-536	. SKIN,RH TRAILING EDGE FAIRING	1			
	95-110014-589	. DOUBLER	3			
	HS51086	. BUTTON,LH PLUG.	1			
- 53	95-110014-131	ANGLE,LH TRAILING EDGE RIB/STA 54/.	1			
	95-110014-132	ANGLE,RH TRAILING EDGE RIB/STA 54/.	1			
- 54	95-110014-125	ANGLE,LH TRAILING EDGE RIB/STA 64/.	1			
	95-110014-126	ANGLE,RH TRAILING EDGE RIB/STA 64/.	1			
- 55	95-110014-155	ANGLE,LH TRAILING EDGE RIB/STA 74.9/.	1			
	95-110014-156	ANGLE,RH TRAILING EDGE RIB/STA 74.9/.	1			
- 56	95-110014-123	ANGLE,LH TRAILING EDGE RIB/STA 117/.	1			
	95-110014-124	ANGLE,RH TRAILING EDGE RIB/STA 117/.	1			
	60-369000-627	SWITCH ASSY,FLAP LIMIT.	1			
		/ATTACHING PARTS/				
	AN515-6-48	SCREW	1			
	AN507-632-28	SCREW	1			
	AN507-632-18	SCREW	1			
	AN936A6	WASHER.	3			
	MS35649-262	NUT	3			

- 56A	AN3169-1	ACTUATOR,FLAP LIMIT SWITCH.	3			
	IN5825	DIODE	1			
	AN742-4	CLAMP	1			
	35-364238	INSULATOR	1			
- 57	60-369000-105	PLATE,SUPPORT	2			
		/ATTACHING PARTS/				
- 58	60-369000-91	STUD.	1			
	AN340-10	NUT	2			
	AN960-10	WASHER.	2			
	AN936A10	WASHER,LOCK	1			
	130909N29	NUT	2			

- 59	95-110014-889	SKIN,LH UPPER/STA 117 TO 131/.	1			
	95-110014-890	SKIN,RH UPPER/STA 117 TO 131/.	1			
- 60	95-110014-895	SKIN,LH & RH LOWER/STA 117 TO 131/.	1			
- 61	95-110014-823	SKIN,LH UPPER/STA 131/.	1			
	95-110014-824	SKIN,RH UPPER/STA 131/.	1			
- 62	95-110014-825	SKIN,LH LOWER/STA 131/.	1			
	95-110014-826	SKIN,RH LOWER/STA 131/.	1			
- 63	95-110014-891	SKIN,LH & RH UPPER/STA 131 TO 184/.	1			
- 64	95-110014-897	SKIN,LH & RH LOWER/STA 131 TO 184/.	1			
- 65	95-110014-831	SKIN,LH UPPER/STA 184/.	1			
	95-110014-832	SKIN,RH UPPER/STA 184/.	1			
- 66	95-110014-833	SKIN,LH LOWER/STA 184/.	1			
	95-110014-834	SKIN,RH LOWER/STA 184/.	1			
- 67	95-110014-893	SKIN,LH & RH UPPER/STA 184 TO 199/.	1			
- 68	95-110014-899	SKIN,LH & RH LOWER/STA 184 TO 199/.	1			
	95-110014-425	SKIN,RH LOWER HALF.	1			
	95-110014-431	SKIN,RH LOWER HALF.	1			

END

BEECHCRAFT
DUKE B60
ILLUSTRATED PARTS CATALOG

57-20-30
WING TIP/EXTENDED/

BEECHCRAFT
DUKE B60
ILLUSTRATED PARTS CATALOG

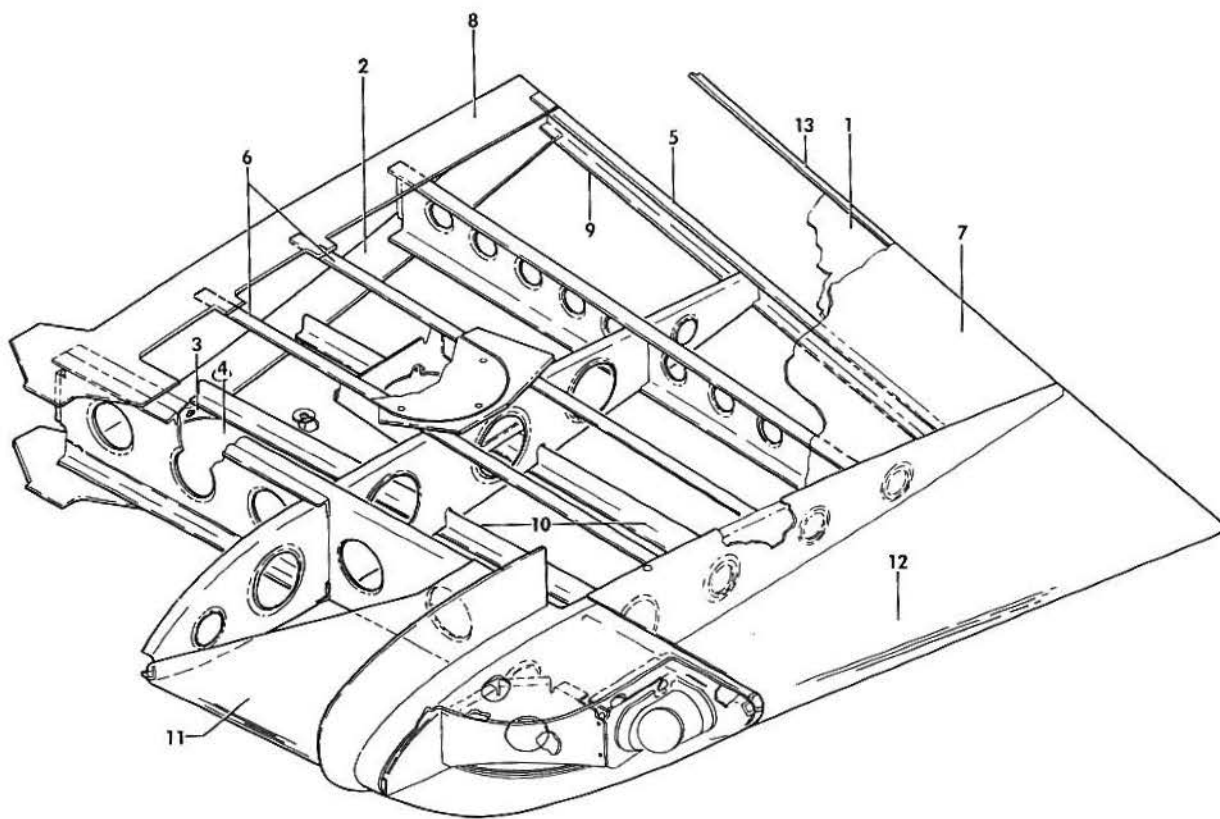
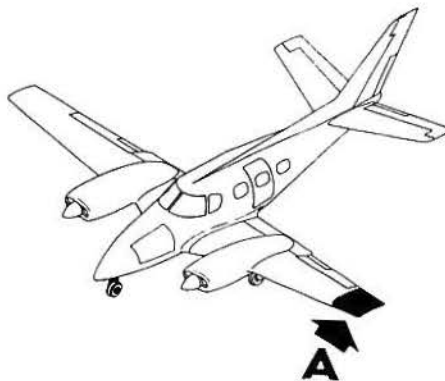

VIEW A

B60-39.2

B E E C H C R A F T
DUKE B60
I L L U S T R A T E D P A R T S C A T A L O G

GAMA/ATA CODE & INDEX NO.	PART NO.	DESCRIPTION	UNITS PER ASSY	USABLE ON CODE
		1 2 3 4 5 6 7		
20-30	R 000-017000-5	WING TIP ASSY,EXTENDED LH	1	3
	000-170000-7	WING TIP ASSY,EXTENDED LH	1	4
	000-170000-71	WING TIP ASSY,EXTENDED LH/STANDARD,FOR OPTIONAL WING TIP SEE CHAPTER 57-20-31/	1	5
	000-017000-6	WING TIP ASSY,EXTENDED RH	1	3
	000-170000-6	WING TIP ASSY,EXTENDED RH	1	4
	000-170000-72	WING TIP ASSY,EXTENDED RH/STANDARD,FOR OPTIONAL WING TIP SEE CHAPTER 57-20-31/	1	5
	000-017000-21	. . . STRUCTURE ASSY,LH	1	3
	R 000-170000-1	. . . STRUCTURE ASSY,LH	1	1
	R 000-170000-77	. . . STRUCTURE ASSY,LH	1	2
	000-017000-22	. . . STRUCTURE ASSY,RH	1	3
	R 000-170000-2	. . . STRUCTURE ASSY,RH	1	1
	R 000-170000-78	. . . STRUCTURE ASSY,RH	1	2
	000-017000-27	. . . SKIN ASSY,LOWER WING TIP LH	1	3
	000-170000-15	. . . SKIN ASSY,LOWER WING TIP LH	1	6
	000-017000-28	. . . SKIN ASSY,LOWER WING TIP RH	1	3
	000-170000-16	. . . SKIN ASSY,LOWER WING TIP RH	1	6
- 1	000-017000-29	. . . SKIN,LOWER LH	1	3
	000-170000-31	. . . SKIN,LOWER LH	1	6
	000-017000-30	. . . SKIN,LOWER RH	1	3
	000-170000-32	. . . SKIN,LOWER RH	1	6
- 2	000-170018-3	. . . REINFORCEMENT	1	
- 3	000-170015-3	. . . REINFORCEMENT	1	
- 4	000-170015-1	. . . COVER,LH ACCESS	1	
	000-170015-2	. . . COVER,RH ACCESS	1	
		/ATTACHING PARTS/		
	MS27039B0807	. . . SCREW	10	
	MS21070L08K	. . . NUTPLATE	10	3
	MS21070L08K	. . . NUTPLATE	9	6
	MS21071L08K	. . . NUTPLATE	1	6
- 5	000-170022-1	. . . STRINGER	1	
- 6	000-170023-1	. . . STRINGER	2	
	000-017000-23	. . . SKIN ASSY,UPPER LH	1	3
	000-170000-13	. . . SKIN ASSY,UPPER LH	1	6
	000-017000-24	. . . SKIN ASSY,UPPER RH	1	3
	000-170000-14	. . . SKIN ASSY,UPPER RH	1	6
- 7	000-017000-25	. . . SKIN,UPPER LH	1	3
	000-170000-29	. . . SKIN,UPPER LH	1	6
	000-017000-26	. . . SKIN,UPPER RH	1	3
	000-170000-30	. . . SKIN,UPPER RH	1	6
- 8	000-170018-3	. . . REINFORCEMENT	1	
- 9	000-170022-3	. . . STRINGER	1	
- 10	000-170023-1	. . . STRINGER	2	
- 11	000-017000-17	. . . SKIN,LEADING EDGE LH	1	3
	000-170000-21	. . . SKIN,LEADING EDGE LH	1	6
	000-017000-18	. . . SKIN,LEADING EDGE RH	1	3
	000-170000-22	. . . SKIN,LEADING EDGE RH	1	6
- 12	000-170000-55	. . . SKIN,TIP LH	1	
	000-170000-56	. . . SKIN,TIP RH	1	
- 13	000-170000-19	. . . WEDGE	1	

BEECHCRAFT
DUKE B60
ILLUSTRATED PARTS CATALOG

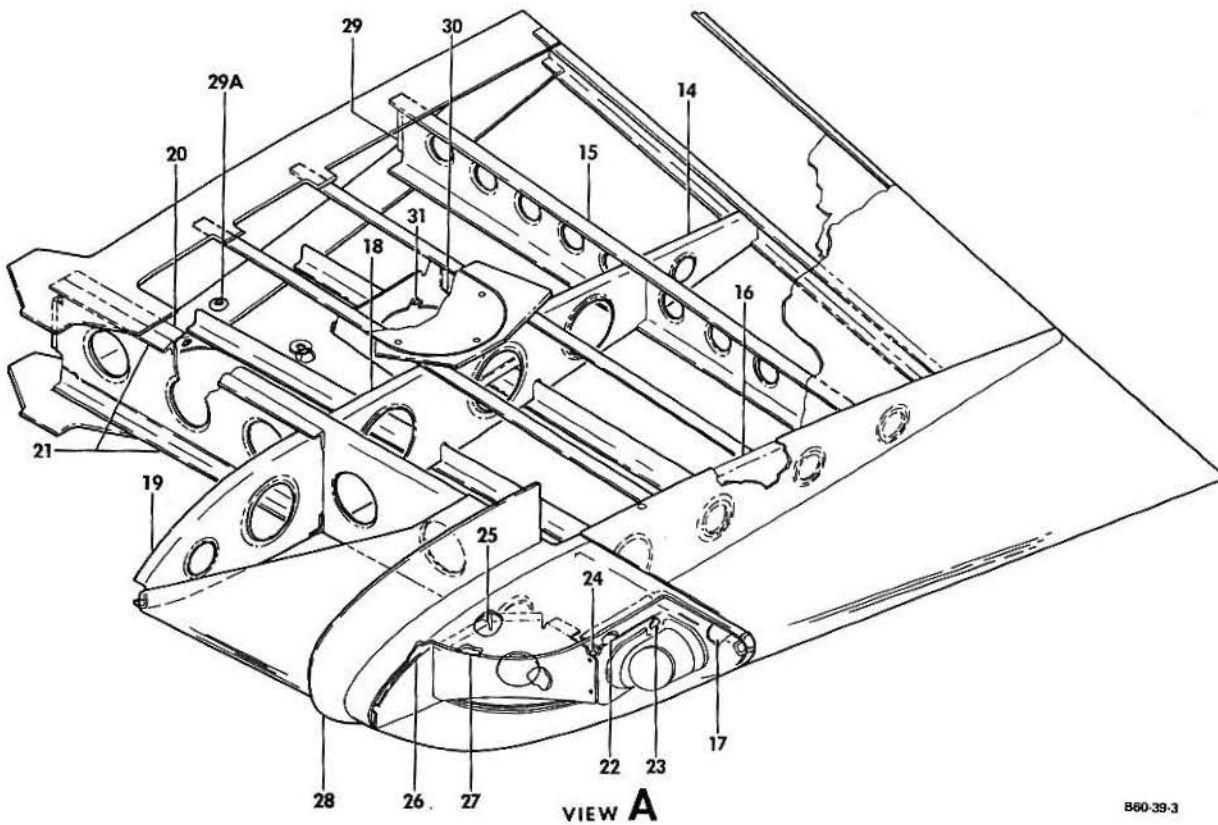
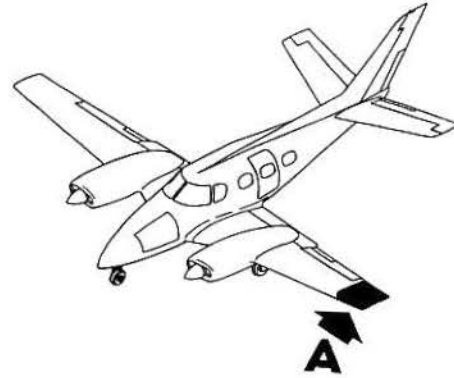

B60-39-3

B E E C H C R A F T
DUKE B60
I L L U S T R A T E D P A R T S C A T A L O G

GAMA/ATA CODE & INDEX NO.	PART NO.	DESCRIPTION							UNITS PER ASSY	USABLE ON CODE
		1	2	3	4	5	6	7		
20-30 - 14	000-170012-5	1	
	000-170012-6	1	
- 15	000-170011-3	1	
	000-170011-4	1	
- 16	000-170013-5	1	9
R	000-170013-13	1	10
	000-170013-6	1	9
R	000-170013-14	1	10
- 17	000-170014-1	1	
	000-170014-2	1	
	MS21069L08K	2	
- 18	000-170012-3	1	
	000-170012-4	1	
- 19	000-170012-1	1	
	000-170012-2	1	
	000-170010-7	1	
	000-170010-8	1	
- 20	000-170010-9	1	
	000-170010-10	1	
- 21	000-170010-5	2	
	000-170016-1	1	
	000-170016-2	1	
- 22	000-170016-3	1	
	000-170016-4	1	
- 23	MS21073L04K	3	
- 24	MS21073L08K	2	
- 25	000-170017-1	1	
	000-170017-2	1	
- 26	000-170020-1	2	
- 27	000-170021-1	2	
- 28	R 000-170000-23	1	13
R	000-170000-73	1	2
R	000-170000-24	1	13
R	000-170000-74	1	2
- 29	000-170000-33	1	
- 29A	S43	1	11
	000-170000-57	1	7
- 30	000-170000-59	1	7
- 31	MS21070L06K	5	
	000-170000-37	1	
	000-170000-38	1	
	MS35206-216	1	
	MS24693S5	2	
	MS21104D6	1	4
	MS35219-55	1	4
	AN960PD10L	1	4
	MS21083D3	1	4

BEECHCRAFT
DUKE B60
ILLUSTRATED PARTS CATALOG

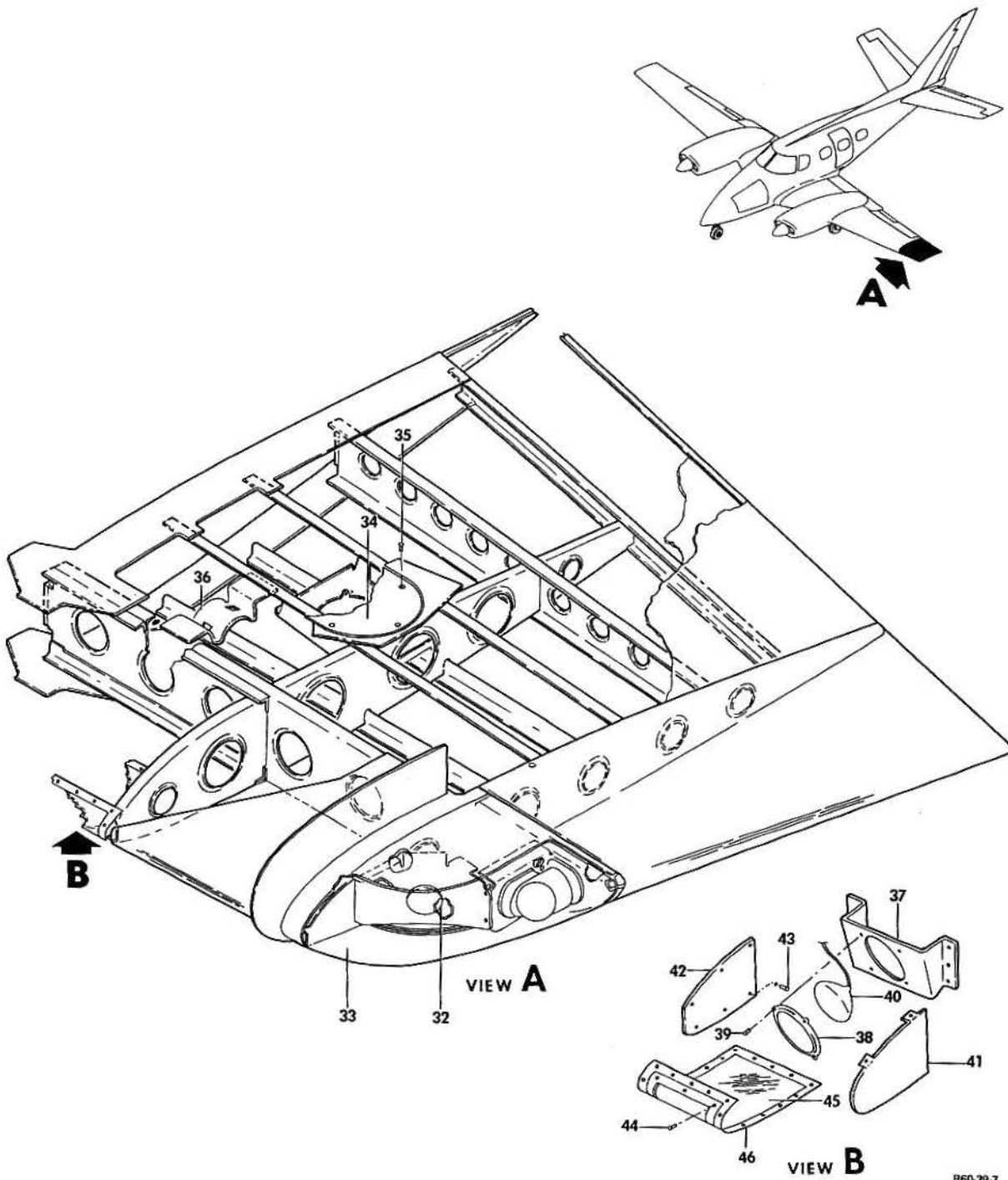

B60-39-7

B E E C H C R A F T
DUKE B60
I L L U S T R A T E D P A R T S C A T A L O G

GAMA/ATA CODE & INDEX NO.	PART NO.	DESCRIPTION							UNITS PER ASSY	USABLE ON CODE
		1	2	3	4	5	6	7		
20-30 - 32	XS48175	•	BUTTON,PLUG	1	
- 33	000-170000-53	•	COVER,NAVIGATION LIGHT LENS LH.	1	
	000-170000-54	•	COVER,NAVIGATION LIGHT LENS RH.	1	
	AN525-832R7	•	SCREW	2	
- 34	000-110085-3	•	COVER,REMOTE COMPASS/LH ONLY/ /ATTACHING PARTS/	1	7
- 35	MS24693BB50	•	SCREW	6	
	MS21050L08	•	NUTPLATE.	6	
- 36	000-170029-1	•	BRACKET,FUEL VENT	1	
	000-170000-35	•	HARNES,LANDING LIGHT	1	8
- 37	000-170025-1	•	BRACKET,LANDING LIGHT LH.	1	8
	000-170025-2	•	BRACKET,LANDING LIGHT RH.	1	8
- 38	000-170026-1	•	RING,LAMP RETAINER. /ATTACHING PARTS/	1	8
- 39	MS27039-0806	•	SCREW	4	
	AN960D8L	•	WASHER.	4	
	130290-3	•	NUT,CLIP.	4	
- 40	4596	•	LAMP,LANDING LIGHT.	1	
- 41	000-170027-1	•	RIB,CLOSURE	1	
	000-170027-2	•	RIB,CLOSURE	1	
- 42	96-170000-49	•	REFLECTOR,LANDING LIGHT /ATTACHING PARTS/	1	9
- 43	AN515C6R6	•	SCREW	6	
	AN960C6L	•	WASHER.	6	
	000-170000-39	•	REFLECTOR,LANDING LIGHT	1	10
	96-170000-65	•	PANE & RETAINER ASSY,LH/WITHOUT DEICER/	1	12
	95-970000-603	•	PANE & RETAINER ASSY,LH/WITH DEICER/.	1	12
	96-170000-66	•	PANE & RETAINER ASSY,RH/WITHOUT DEICER/	1	12
	95-970000-604	•	PANE & RETAINER ASSY,RH/WITH DEICER/.	1	12
- 44	MS24693S4	•	SCREW	10	
	AN960D4	•	WASHER.	10	
	MS21042L04	•	NUT	10	
- 45	96-170000-7	•	LENS,LH LANDING LIGHT	1	12
	96-170000-8	•	LENS,RH LANDING LIGHT	1	12
- 46	96-170000-9	•	RETAINER,LH LENS/WITHOUT DEICER/.	1	12
	95-970000-179	•	RETAINER,LH LENS/WITH DEICER/	1	12
	96-170000-10	•	RETAINER,RH LENS/WITHOUT DEICER/.	1	12
	95-970000-180	•	RETAINER,RH LENS/WITH DEICER/	1	12

CODES OF EFFECTIVITY

1	P-310 THRU P-445	2	P-446 AND AFTER
3	P-247 THRU P-309	4	P-310 THRU P-347, P-349 THRU P-364
5	P-348, P-365 AND AFTER	6	P-310 AND AFTER
7	P-247 THRU P-295, P-297 THRU P-347, P-349 THRU P-364	8	P-247 THRU P-347 P-349 THRU P-364
9	P-247 THRU P-384	10	P-385 AND AFTER
11	P-348, P-355 AND AFTER	12	P-247 THRU P-327
13	P-247 THRU P-445		

B E E C H C R A F T
DUKE B60
I L L U S T R A T E D P A R T S C A T A L O G

57-20-31
WET WING TIP/OPTIONAL/
P-348,P-365 AND AFTER

BEECHCRAFT
DUKE B60
ILLUSTRATED PARTS CATALOG

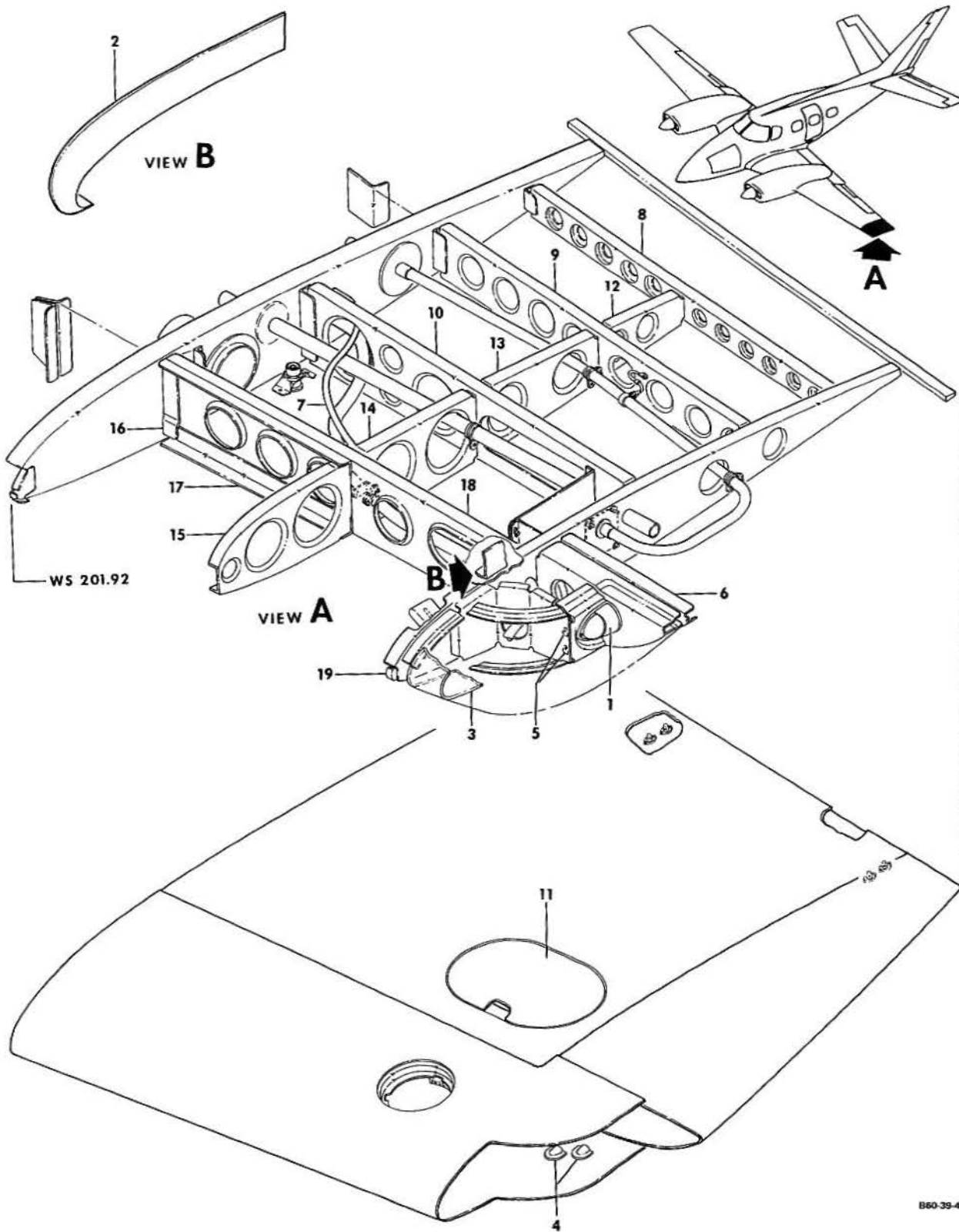

B E E C H C R A F T
DUKE B60
I L L U S T R A T E D P A R T S C A T A L O G

GAMA/ATA CODE & INDEX NO.	PART NO.	DESCRIPTION	1 2 3 4 5 6 7							UNITS PER ASSY	USABLE ON CODE
			1	2	3	4	5	6	7		
20-31	60-170010-603	WET WING TIP ASSY,LH/OPTIONAL/.	1	1
	60-170010-604	WET WING TIP ASSY,RH/OPTIONAL/.	1	1
NOTE SEE SERVICE INSTRUCTIONS NO.0913 FOR KIT TO.INSTALL WET WING TIP ON AIRPLANES NOT FACTORY EQUIPPED.											
- 1	000-170000-37	. HARNESS ASSEMBLY,LH	1	1
	000-170000-38	. HARNESS ASSEMBLY,RH	1	1
		/ATTACHING PARTS/									
	MS24693S5	. SCREW	2	
	MS35206-216	. SCREW	1	
- 2	000-170000-23	. GLARESHIELD,LH.	1	6
	000-170000-24	. GLARESHIELD,RH.	1	6
	000-170000-73	. GLARESHIELD,LH.	1	7
	000-170000-74	. GLARESHIELD,RH.	1	7
- 3	000-170000-53	. COVER,LENS LH	1	1
	000-170000-54	. COVER,LENS RH	1	1
		/ATTACHING PARTS/									
	MS15985-8R7	. SCREW	2	
	AN960PD8L	. WASHER.	2	
	MS21069L08K	. NUTPLATE.	2	
- 4	S43	. GROMMET, DRAIN HOLE.	2	1
- 5	MS21073L08K	. NUTPLATE.	2	1
	60-170010-605	. STRUCTURE ASSY,LH	1	1
	60-170010-606	. STRUCTURE ASSY,RH	1	1
- 6	60-170010-4	. RIB,LH.	1	1
	60-170010-3	. RIB,RH.	1	1
- 7	60-170010-5	. TUBE ASSY,LH.	1	1
	60-170010-6	. TUBE ASSY,RH.	1	1
- 8	60-170010-7	. SPAR,LH	1	1
	60-170010-8	. SPAR,RH	1	1
- 9	60-170010-9	. REAR SPAR,LH.	1	1
	60-170010-10	. REAR SPAR,RH.	1	1
- 10	60-170010-71	. SPAR ASSY,LH/47.5%/	1	1
	60-170010-72	. SPAR ASSY,RH/47.5%/	1	1
	60-170010-11	. SPAR,LH	1	1
	60-170010-12	. SPAR,RH	1	1
	MS21059L3	. NUTPLATE.	2	1
- 11	60-170010-15	. PANEL ASSY.	1	1
		/ATTACHING PARTS/									
	NAS1202-2	. BOLT.	16	
	60-170010-13	. PANEL,ACCESS.	1	1
	NAS1474A08	. NUTPLATE.	16	1
- 12	60-170010-17	. RIB,LH.	1	1
	60-170010-18	. RIB,RH.	1	1
- 13	60-170010-19	. RIB,LH.	1	1
	60-170010-20	. RIB,RH.	1	1
- 14	60-170010-21	. RIB,LH.	1	1
	60-170010-22	. RIB,RH.	1	1
- 15	60-170010-23	. RIB,LH.	1	1
	60-170010-24	. RIB,RH.	1	1
- 16	60-170010-25	. CLIP.	1	1
- 17	60-170010-27	. ANGLE,LH.	1	1
	60-170010-28	. ANGLE,RH.	1	1
- 18	60-170010-29	. MAIN SPAR,LH.	1	1
	60-170010-30	. MAIN SPAR,RH.	1	1
- 19	60-170010-33	. PLUG,LH	1	1
	60-170010-34	. PLUG,RH	1	1

BEECHCRAFT
DUKE B60
ILLUSTRATED PARTS CATALOG

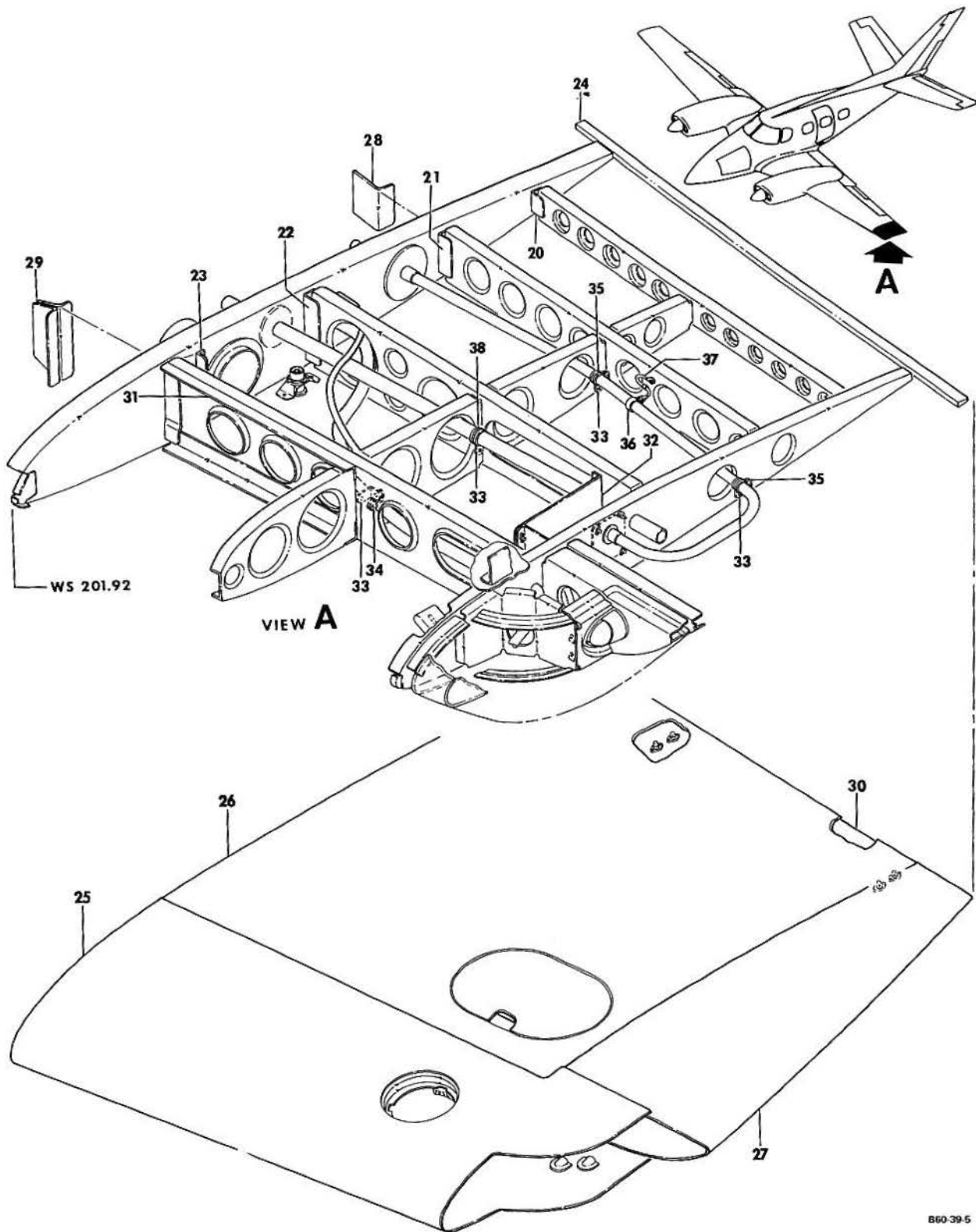

B E E C H C R A F T
DUKE B60
I L L U S T R A T E D P A R T S C A T A L O G

GAMA/ATA CODE & INDEX NO.	PART NO.	DESCRIPTION							UNITS PER ASSY	USABLE ON CODE
		1	2	3	4	5	6	7		
20-31 - 20	60-170010-35	1	1
- 21	60-170010-37	1	1
- 22	60-170010-39	1	1
- 23	60-170010-41	1	1
- 24	60-170010-51	1	1
- 25	60-170010-53	1	1
	60-170010-54	1	1
- 26	60-170010-55	1	1
	60-170010-56	1	1
- 27	60-170010-57	1	1
	60-170010-58	1	1
- 28	60-170010-95	1	1
- 29	60-170010-97	2	1
- 30	60-170010-63	1	1
	60-170010-64	1	1
- 31	60-170010-65	1	1
	60-170010-66	1	1
- 32	60-170010-67	1	1
	60-170010-68	1	1
		/ATTACHING PARTS/								
	130909B12	4	
	MS21059L3	2	
- 33	60-170010-87	4	1
- 34	MS21919F8	1	1
	MS21919F4	1	1
		/ATTACHING PARTS/								
	MS35206-262	1	
	AN960-10L	1	
	MS21042L3	1	
- 35	MS21919F8	2	1
		/ATTACHING PARTS/								
	MS35206-262	1	
	AN960-10L	1	
	MS21042L3	1	
- 36	AN735D8	1	1
		/ATTACHING PARTS/								
	MS35206-262	1	
	AN960-10L	2	
	MS21042L3	1	
- 37	MS25083-1B85	1	1
		/ATTACHING PARTS/								
	MS35206-262	1	
	AN960-10L	1	
	AN960PD10L	2	
	MS21042L3	1	
- 38	MS21919F12	1	1
		/ATTACHING PARTS/								
	MS35206-262	1	
	AN960-10L	1	
	MS21042L3	1	

BEECHCRAFT
DUKE B60
ILLUSTRATED PARTS CATALOG

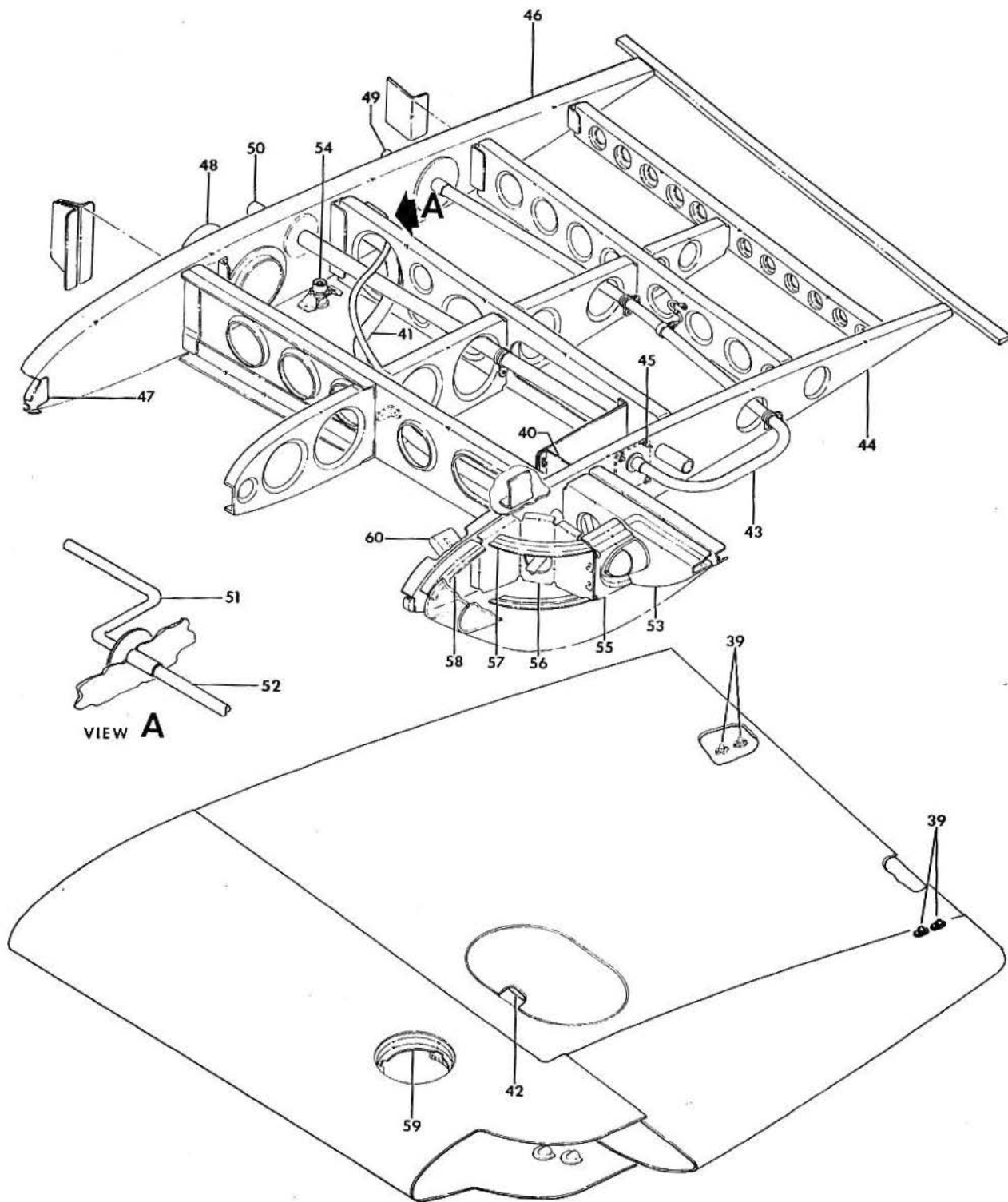

860-39-8

B E E C H C R A F T
DUKE B60
I L L U S T R A T E D P A R T S C A T A L O G

SUB-SECT UNIT & ITEM NO.	PART NO.	DESCRIPTION	UNITS PER ASSY	USABLE ON CODE
		1 2 3 4 5 6 7		
20-31 - 39	NAS1474A06	. . CAP NUT,STATIC WICK	4	1
- 40	60-170010-69	. . BAFFLE.	1	1
- 41	60-170010-73	. . TUBE ASSY,LH.	1	1
	60-170010-74	. . TUBE ASSY,RH.	1	1
- 42	60-170010-77	. . GASKET.	1	1
- 43	60-170010-79	. . TUBE,VENT	1	1
- 44	000-170013-9	. . RIB,LH.	1	1
	000-170013-10	. . RIB,RH.	1	1
- 45	60-910064-3	. . ADAPTER ASSY.	1	1
	NAS1068A3	. . NUTPLATE.	4	
- 46	60-170011-3	. . RIB,LH.	1	1
	60-170011-4	. . RIB,RH.	1	1
- 47	60-170011-5	. . END,LH.	1	1
	60-170011-6	. . END,RH.	1	1
- 48	60-170011-7	. . TUBE ASSY	1	1
- 49	60-170012-1	. . ADAPTER,VENT.	1	1
- 50	60-170012-13	. . ADAPTER ASSY.	1	1
- 51	60-921058-1	. . ADAPTER ASSY,WING TIP VENT.	1	4
	60-921060-1	. . ADAPTER ASSY,WING TIP VENT.	1	5
- 52	60-170010-99	. . TUBE ASSY,WING TIP VENT	1	8
	MS21919F4	. . CLAMP	2	
	MS35206-262	. . SCREW	2	
	AN960-10L	. . WASHER.	2	
	MS21042L3	. . NUT	2	
	106200H4-4	. . HOSE.	1	1
	60-170010-87	. . SUPPORT	1	1
- 53	60-170010-89	. . FORMER,LH	1	1
	60-170010-90	. . FORMER,RH	1	1
- 54 R	966B1	. . VALVE,DRAIN/ALTERNATE FOR 78-1021/.	1	1
R	78-1021	. . VALVE,DRAIN/ALTERNATE FOR 966B1/.	1	1
R	MS29513-20	. . O RING.	1	1
	1006C	. . RETAINER,DRAIN VALVE.	1	1
- 55	000-170016-1	. . BRACKET ASSY,LH	1	1
	000-170016-2	. . BRACKET ASSY,RH	1	1
- 56	000-170017-1	. . FORMER ASSY,LH.	1	1
	000-170017-2	. . FORMER ASSY,RH.	1	1
- 57	000-170021-1	. . RETAINER.	2	1
- 58	000-170020-1	. . RETAINER.	2	1
- 59	96-380036-15	. . ADAPTER ASSY.	1	2
	60-170010-607	. . ADAPTER ASSY.	1	3
- 60 R	60-920016-11	. . VALVE ASSY,FLOAT.	1	1
	100-920048-17	. . GASKET,FLOAT VALVE.	1	1
	130909B17	. . BOLT.	4	
	AN960PD10	. . WASHER.	4	
	60-170010-93	. . PAD,SCUFF	1	1
	AN3DD5A	. . BOLT.	3	1
	AN960D10L	. . WASHER.	3	1
	60-170010-113	. . CLAMP ASSY.	1	1
	60-170010-111	. . STRIP	1	1
	NAJ401-028C	. . NUTPLATE.	3	1

CODES OF EFFECTIVITY

1	P-348,	2	P-348
	P-365 AND AFTER		
3	P-365 AND AFTER	4	P-383 THRU P-432
5	P-433 AND AFTER	6	P-348,
			P-365 THRU P-445
7	P-446 AND AFTER	8	P-383 AND AFTER

B E E C H C R A F T
DUKE B60
I L L U S T R A T E D P A R T S C A T A L O G

57-30-01
WING SKINS

BEECHCRAFT
DUKE B60
ILLUSTRATED PARTS CATALOG

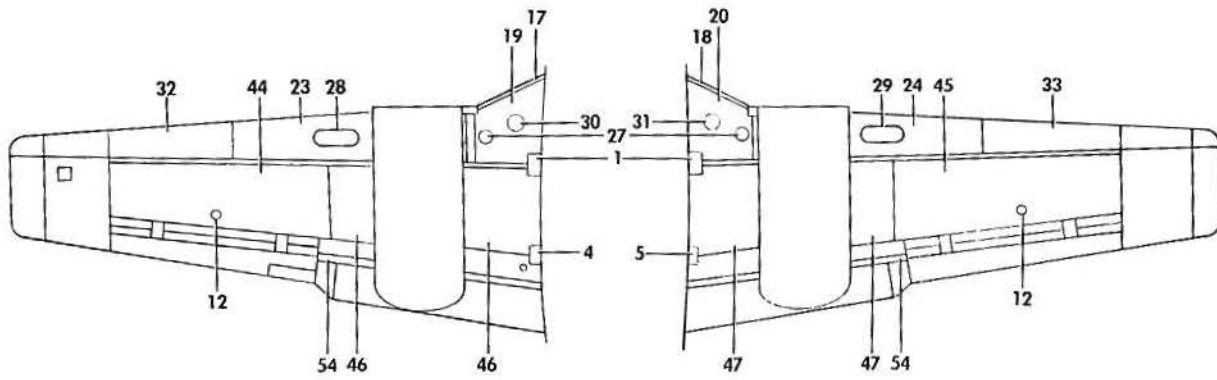

LEFT WING (UPPER)

RIGHT WING (UPPER)

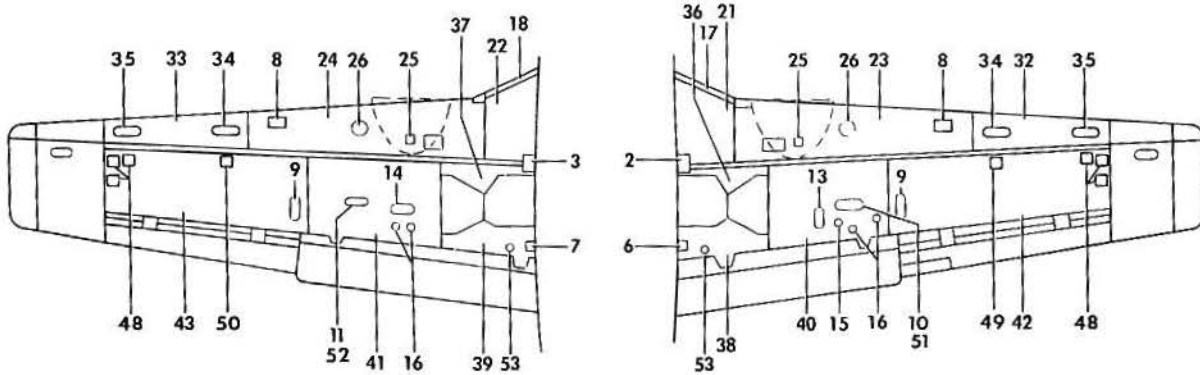

RIGHT WING (LOWER)

LEFT WING (LOWER)

B60-13-8

B E E C H C R A F T
DUKE B60
I L L U S T R A T E D P A R T S C A T A L O G

GAMA/ATA CODE & INDEX NO.	PART NO.	DESCRIPTION	UNITS PER ASSY	USABLE ON CODE
		1 2 3 4 5 6 7		
30-01 - 1	60-100018-13	DOOR ASSY,UPPER FWD LH & RH WING BOLT ACCESS.	1	
- 2	60-100018-17	DOOR ASSY,LOWER FWD LH WING BOLT ACCESS	1	
- 3	60-100018-18	DOOR ASSY,LOWER FWD RH WING BOLT ACCESS	1	
- 4	35-105005-12	DOOR ASSY,UPPER AFT LH WING BOLT ACCESS	1	
- 5	35-105005-13	DOOR ASSY,UPPER AFT RH WING BOLT ACCESS	1	
- 6	60-100018-7	DOOR ASSY,LOWER AFT LH WING BOLT ACCESS	1	
- 7	60-100018-8	DOOR ASSY,LOWER AFT RH WING BOLT ACCESS	1	
- 8	50-110010-163	DOOR,LEADING EDGE ACCESS LH & RH.	1	
- 9	95-110014-339	DOOR ASSY,AILERON TRIM TAB ACTUATOR AND	1	
		PULLEY ACCESS LH & RH		
- 10	R 50-110074-5	DOOR,LH AUXILIARY TANK ACCESS/OUTER/.	1	
- 11	R 50-110074-6	DOOR,RH AUXILIARY TANK ACCESS/OUTER/.	1	
- 12	50-110025-44	DOOR,AUXILIARY TANK TRANSMITTER LH & RH	1	
- 13	95-110014-1001	DOOR,AILERON CABLE INSPECTION LH.	1	
- 14	35-115199-12	DOOR,AILERON CABLE INSPECTION RH.	1	
- 15	95-110014-1007	DOOR,CABLE ACCESS LH.	1	
- 16	35-115200-42	DOOR,CABLE ACCESS LH & RH	2	
- 17	60-110012-53	SKIN,LEADING EDGE INBD LH/STA 32.8 TO 55.9/	1	
- 18	60-110012-54	SKIN,LEADING EDGE INBD RH/STA 32.8 TO 55.9/	1	
- 19	60-110012-55	SKIN,LEADING EDGE UPPER LH.	1	
- 20	60-110012-56	SKIN,LEADING EDGE UPPER RH.	1	
- 21	60-110012-57	SKIN,LEADING EDGE LOWER LH.	1	
- 22	60-110012-58	SKIN,LEADING EDGE LOWER RH.	1	
- 23	96-100016-367	SKIN,LEADING EDGE LH/STA 55.9 TO 131.67/.	1	
- 24	96-100016-368	SKIN,LEADING EDGE RH/STA 55.9 TO 131.67/.	1	
- 25	35-115431-173	DOOR ASSY,LANDING GEAR ACCESS LH & RH	1	
- 26	60-110014-601	DOOR ASSY,FUEL CELL INTERCONNECT ACCESS LH & RH	1	1
	000-110157-1	DOOR ASSY,FUEL CELL INTERCONNECT ACCESS LH & RH	1	2
- 27	60-110032	COVER,FUEL TRANSMITTER ACCESS LH & RH	1	
- 28	96-100016-113	DOOR ASSY,FUEL CELL ACCESS LH	1	
- 29	96-100016-114	DOOR ASSY,FUEL CELL ACCESS RH	1	
- 30	R 000-110240-1	DOOR ASSY,FUEL BOOST PUMP ACCESS LH	1	
- 31	K 000-110240-2	DOOR ASSY,FUEL BOOST PUMP ACCESS RH	1	
- 32	96-100016-399	SKIN,LEADING EDGE OUTBD LH.	1	1
	000-110029-3	SKIN,LEADING EDGE OUTBD LH.	1	2
- 33	96-100016-400	SKIN,LEADING EDGE OUTBD RH.	1	
	000-110029-53	SKIN,LEADING EDGE OUTBD RH.	1	2
- 34	96-100016-395	DOOR ASSY,INBD LINER ACCESS LH & RH	1	1
	000-110029-57	DOOR ASSY,INBD LINER ACCESS LH & RH	1	2
- 35	96-100016-305	DOOR ASSY,OUTBD LINER ACCESS LH & RH.	1	1
	000-110029-49	DOOR ASSY,OUTBD LINER ACCESS LH & RH.	1	2
- 36	95-110014-537	SKIN,LOWER LH INBD FWD.	1	
- 37	95-110014-538	SKIN,LOWER RH INBD FWD.	1	
- 38	95-110014-539	SKIN,LOWER LH INBD AFT.	1	3
- 39	95-110014-599	SKIN,LOWER RH INBD AFT.	1	3
	102-100014-41	SKIN,LOWER LH INBD AFT.	1	4
	95-110014-1077	SKIN,LOWER RH INBD AFT.	1	4
- 40	95-110014-205	SKIN,LOWER LH CENTER.	1	
- 41	95-110014-206	SKIN,LOWER RH CENTER.	1	
- 42	95-110014-519	SKIN,LOWER LH OUTBD	1	
- 43	95-110014-520	SKIN,LOWER RH OUTBD	1	
- 44	95-110014-817	SKIN,UPPER LH OUTBD	1	
- 45	95-110014-818	SKIN,UPPER RH OUTBD	1	
- 46	95-110014-921	SKIN,UPPER LH INBD.	1	
- 47	95-110014-480	SKIN,UPPER RH INBD.	1	
- 48	95-110014-253	DOOR,ACCESS LH & RH	3	
- 49	58-110011-1	DOOR ASSY,LH.	1	
- 50	58-110011-2	DOOR ASSY,RH.	1	
	95-110014-653	DOOR ASSY,LH INNER LINER ACCESS	1	
	95-110014-654	DOOR ASSY,LH INNER LINER ACCESS	1	
- 51	50-110002-134	. DOOR,LOWER LH LINER ACCESS.	1	
- 52	50-110002-135	. DOOR,LOWER RH LINER ACCESS.	1	
- 53	95-110014-353	COVER,INSPECTION LH & RH.	1	
- 54	95-110014-857	COVER,SPLICE.	1	

BEECHCRAFT
DUKE B60
ILLUSTRATED PARTS CATALOG

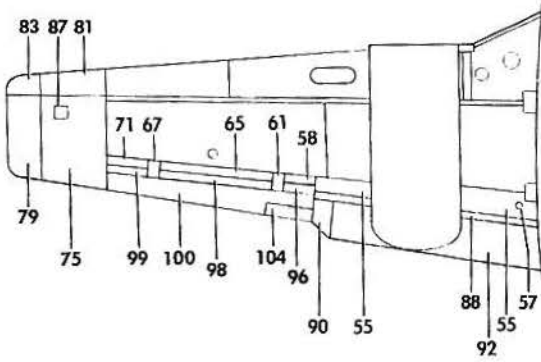

LEFT WING (UPPER)

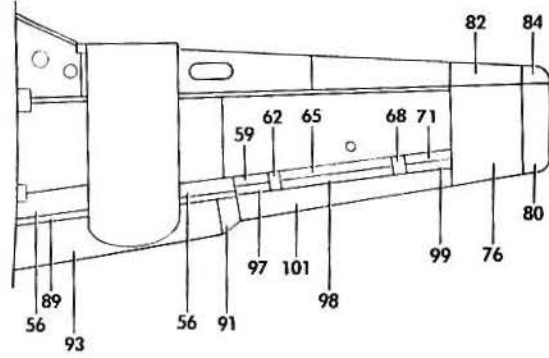

RIGHT WING (UPPER)

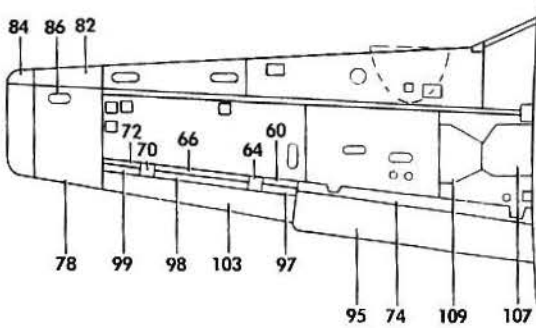

RIGHT WING (LOWER)

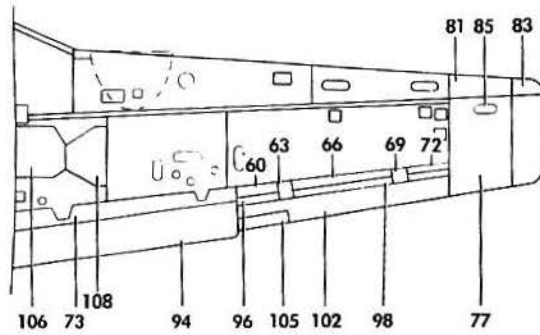

LEFT WING (LOWER)

B60-13-9

B E E C H C R A F T
DUKE B60
I L L U S T R A T E D P A R T S C A T A L O G

GAMA/ATA CODE & INDEX NO.	PART NO.	DESCRIPTION	UNITS PER ASSY	USABLE ON CODE
		1 2 3 4 5 6 7		
30-01 - 55	95-110014-959	SKIN,LH TRAILING EDGE UPPER INBD.	1	
- 56	95-110014-951	SKIN,RH TRAILING EDGE UPPER INBD.	1	
- 57	60-530222-1	RECEPTACLE,DOOR STAY/LH ONLY/	1	
	95-110014-423	SKIN,LH TRAILING EDGE LOWER HALF CONCAVE.	1	
	95-110014-424	SKIN,RH TRAILING EDGE LOWER HALF CONCAVE.	1	
	95-110014-425	SKIN,RH TRAILING EDGE LOWER HALF CONCAVE.	1	
	95-110014-431	SKIN,RH TRAILING EDGE LOWER HALF CONCAVE.	1	
- 58	95-110014-889	SKIN,TRAILING EDGE UPPER LH	1	
- 59	95-110014-890	SKIN,TRAILING EDGE UPPER RH	1	
- 60	95-110014-895	SKIN,TRAILING EDGE LOWER LH & RH.	1	
- 61	95-110014-823	SKIN,TRAILING EDGE UPPER LH	1	
- 62	95-110014-824	SKIN,TRAILING EDGE UPPER RH	1	
- 63	95-110014-825	SKIN,TRAILING EDGE LOWER LH	1	
- 64	95-110014-826	SKIN,TRAILING EDGE LOWER RH	1	
- 65	95-110014-891	SKIN,TRAILING EDGE UPPER LH & RH.	1	
- 66	95-110014-897	SKIN,TRAILING EDGE LOWER LH & RH.	1	
- 67	95-110014-831	SKIN,TRAILING EDGE UPPER LH	1	
- 68	95-110014-832	SKIN,TRAILING EDGE UPPER RH	1	
- 69	95-110014-833	SKIN,TRAILING EDGE LOWER LH	1	
- 70	95-110014-834	SKIN,TRAILING EDGE LOWER RH	1	
- 71	95-110014-893	SKIN,TRAILING EDGE UPPER LH & RH.	1	
- 72	95-110014-899	SKIN,TRAILING EDGE LOWER LH & RH.	1	
- 73	95-110014-869	SKIN,TRAILING EDGE LH LOWER INBD.	1	
- 74	95-110014-870	SKIN,TRAILING EDGE RH LOWER INBD.	1	
- 75	000-017000-25	SKIN,WING TIP UPPER LH.	1	
- 76	000-017000-26	SKIN,WING TIP UPPER RH.	1	
- 77	000-017000-29	SKIN,WING TIP LOWER LH.	1	
- 78	000-017000-30	SKIN,WING TIP LOWER RH.	1	
- 79	000-170000-55	SKIN,WING TIP OUTBD LH.	1	
- 80	000-170000-56	SKIN,WING TIP OUTBD RH.	1	
- 81	000-017000-17	SKIN,WING TIP LEADING EDGE LH	1	
- 82	000-017000-18	SKIN,WING TIP LEADING EDGE RH	1	
- 83	000-170000-53	COVER,NAVIGATION LIGHT LENS LH.	1	
- 84	000-170000-54	COVER,NAVIGATION LIGHT LENS RH.	1	
- 85	000-170015-1	COVER,WING TIP ACCESS LH.	1	
- 86	000-170015-2	COVER,WING TIP ACCESS RH.	1	
- 87	000-110085-3	COVER,REMOTE COMPASS /LH ONLY/.	1	
- 88	95-160000-79	SKIN,LH FLAP LEADING EDGE	1	
- 89	95-160000-80	SKIN,RH FLAP LEADING EDGE	1	
- 90	95-160000-33	SKIN,LH FLAP TIP.	1	
- 91	95-160000-34	SKIN,RH FLAP TIP.	1	
- 92	95-160000-57	SKIN,LH FLAP UPPER.	1	
- 93	95-160000-76	SKIN,RH FLAP UPPER.	1	
- 94	95-160000-59	SKIN,LH FLAP LOWER.	1	
- 95	95-160000-60	SKIN,RH FLAP LOWER.	1	
- 96	60-130001-95	SKIN,LH AILERON FWD INBD.	1	
- 97	60-130001-99	SKIN,RH AILERON FWD INBD.	1	
- 98	60-130001-93	SKIN,LH & RH AILERON FWD CENTER	1	
- 99	60-130001-97	SKIN,LH & RH AILERON FWD OUTBD.	1	
-100	60-130001-21	SKIN,LH AILERON AFT UPPER	1	
-101	60-130001-25	SKIN,RH AILERON AFT UPPER	1	
-102	60-130001-23	SKIN,LH AILERON AFT LOWER	1	
-103	60-130001-27	SKIN,RH AILERON AFT LOWER	1	
-104	60-130011-1	SKIN,LH AILERON TRIM TAB UPPER.	1	
-105	60-130011-3	SKIN,LH AILERON TRIM TAB LOWER.	1	
-106	35-815055-72	DOOR ASSY,MAIN LANDING GEAR INBD LH	1	
-107	35-815055-73	DOOR ASSY,MAIN LANDING GEAR INBD RH	1	
-108	35-815055-84	DOOR ASSY,MAIN LANDING GEAR OUTBD LH.	1	
-109	35-815055-85	DOOR ASSY,MAIN LANDING GEAR OUTBD RH.	1	

CODES OF EFFECTIVITY

1 P-247 THRU P-266 2 P-267 AND AFTER
3 P-247-THRU P-434 4 P-435 AND AFTER

END

BEECHCRAFT
DUKE B60
ILLUSTRATED PARTS CATALOG

57-30-10
WING FAIRINGS

BEECHCRAFT
DUKE B60
ILLUSTRATED PARTS CATALOG

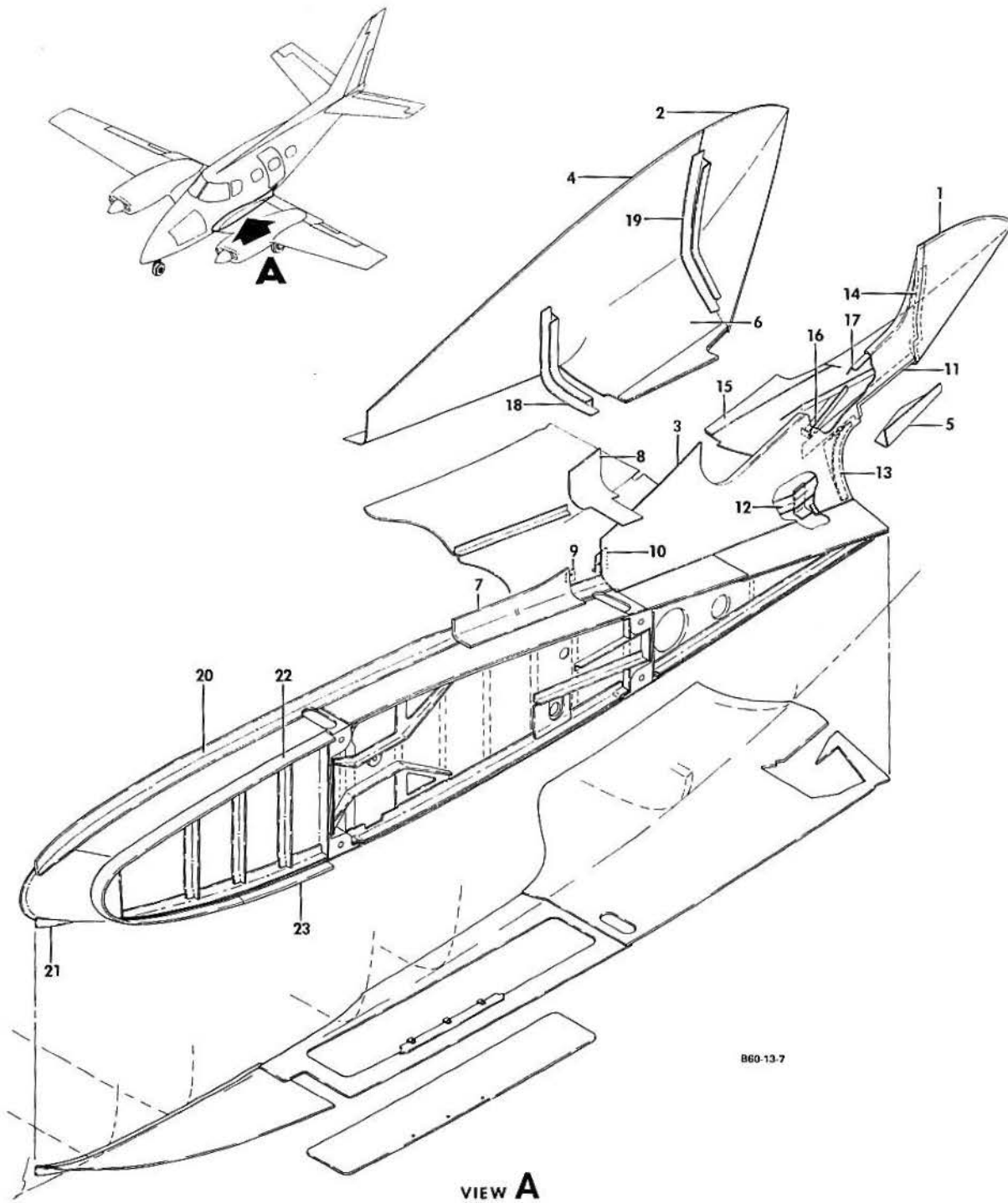

B60-13.7

B E E C H C R A F T
DUKE B60
I L L U S T R A T E D P A R T S C A T A L O G

GAMA/ATA CODE & INDEX NO.	PART NO.	DESCRIPTION							UNITS PER ASSY	USABLE ON CODE
		1	2	3	4	5	6	7		
30-10	60-430134-1	FILLET	INSTL,	WING	TO	FUSELAGE	LH.	NP	
	60-430134-2	FILLET	INSTL,	WING	TO	FUSELAGE	RH.	NP	
- 1	60-430134-3	. SKIN,	LH	WING	TO	FUSELAGE	AFT	FILLET	1	
- 2	60-430134-39	. SKIN,	RH	WING	TO	FUSELAGE	AFT	FILLET	1	
- 3	60-430134-5	. SKIN,	LH	WING	TO	FUSELAGE	CENTER	FILLET.	1	
- 4	60-430134-35	. SKIN,	RH	WING	TO	FUSELAGE	UPPER	CENTER	FILLET.	1
- 5	60-430134-7	. SKIN,	LH	WING	TO	FUSELAGE	LWR	CENTER	FILLET.	1
- 6	60-430134-37	. SKIN,	RH	WING	TO	FUSELAGE	LWR	CENTER	FILLET.	1
- 7	60-430134-9	. SKIN,	LH	WING	TO	FUSELAGE	LWR	FWD	FILLET	1
	60-430134-10	. SKIN,	RH	WING	TO	FUSELAGE	LWR	FWD	FILLET	1
- 8	60-430134-45	. COVER,	LH	WING	STUB	ACCESS/FUS	STA	173.50/	1	
	60-430134-46	. COVER,	RH	WING	STUB	ACCESS/FUS	STA	173.50/	1	
- 9	60-430134-13	. SPLICE,	LH	WING	STUB	ACCESS	COVER	TO	SKIN.	1
	60-430134-14	. SPLICE,	RH	WING	STUB	ACCESS	COVER	TO	SKIN.	1
- 10	60-430134-15	. SPLICE,	LH	WING	STUB	ACCESS	COVER	TO	SKIN	AFT.
	60-430134-16	. SPLICE,	RH	WING	STUB	ACCESS	COVER	TO	SKIN	AFT.
- 11	60-430134-17	. SPLICE,	LH	AFT	FILLET	LWR.				1
- 12	60-430134-19	. SUPPORT,	LH	FILLET					1
- 13	60-430134-21	. SPLICE,	LH	FILLET	LOWER.					1
- 14	60-430134-23	. SPLICE,	LH	AFT					1
- 15	60-430134-25	. COVER,	LH	WING	STUB	ACCESS	LWR			1
- 16	60-430134-27	. ANGLE,	LH	FILLET					1
- 17	60-430134-43	. RETAINER,	LWR	DOOR	FRAME	LH.				1
- 18	60-430135	. SUPPORT,	RH	FILLET/FUS	STA	201/.				1
- 19	60-430136	. SUPPORT,	RH	FILLET/FUS	STA	214/.				1
- 20	60-430022-11	ANGLE,	LH	WING	TO	FUSELAGE	UPPER	FWD		1
	60-430022-12	ANGLE,	RH	WING	TO	FUSELAGE	UPPER	FWD		1
- 21	60-430022-135	ANGLE,	LH	WING	TO	FUSELAGE	LOWER	FWD		1
	60-430022-136	ANGLE,	RH	WING	TO	FUSELAGE	LOWER	FWD		1
- 22	60-100023-1	STRIP,	LH	UPPER	CLOSURE.					1
	60-100023-2	STRIP,	RH	UPPER	CLOSURE.					1
- 23	60-100023-7	STRIP,	LH	LOWER	CLOSURE.					1
	60-100023-8	STRIP,	RH	LOWER	CLOSURE.					1

"END"

B E E C H C R A F T
DUKE 860
I L L U S T R A T E D P A R T S C A T A L O G

57-40-01
WING INSTALLATION

BEECHCRAFT
DUKE B60
ILLUSTRATED PARTS CATALOG

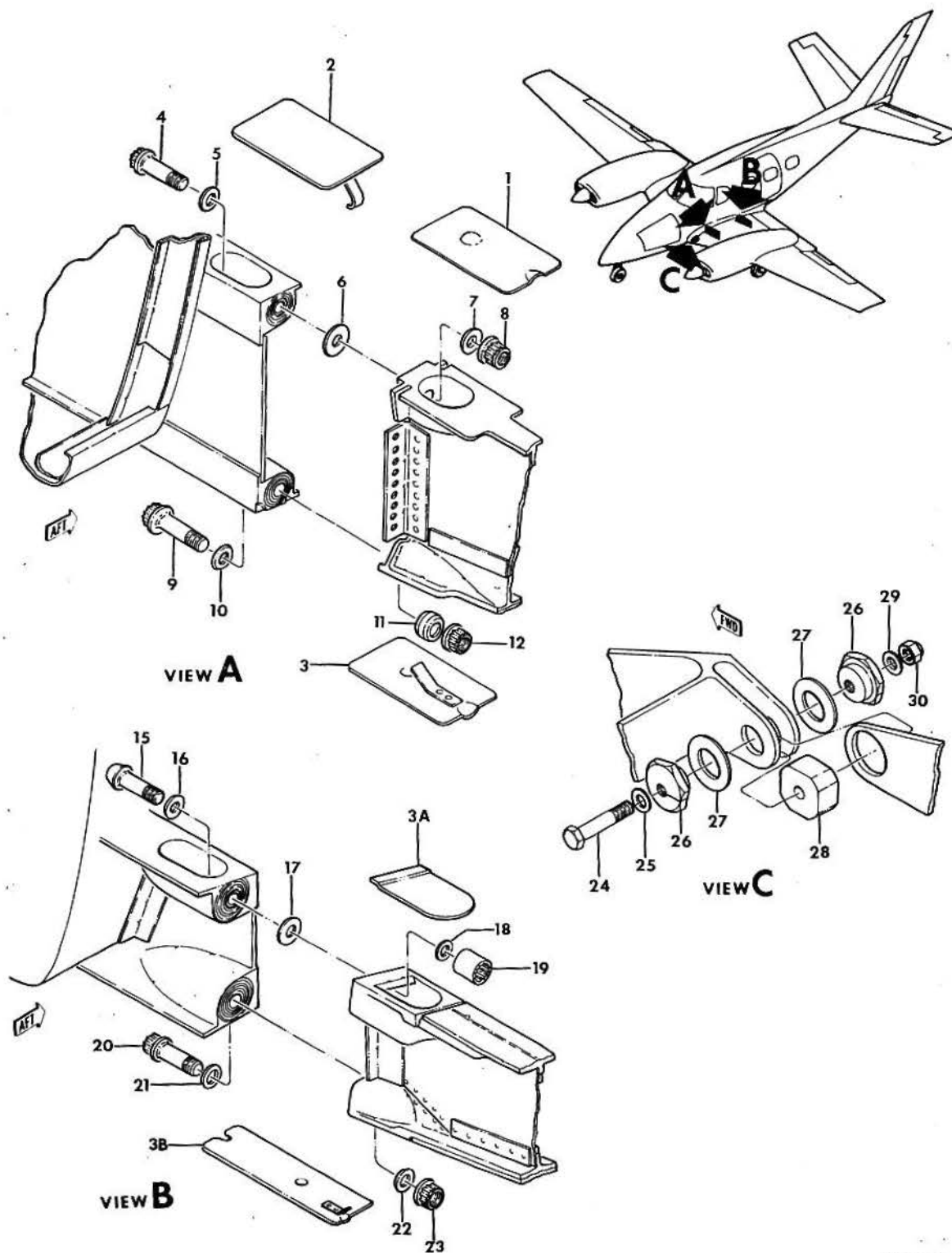

B60-31-5

B E E C H C R A F T
DUKE B60
I L L U S T R A T E D P A R T S C A T A L O G

SUB-SECT UNIT & ITEM NO.	PART NO.	DESCRIPTION	UNITS PER ASSY	USABLE ON CODE
		1 2 3 4 5 6 7		
40-01	60-100000-1	WING INSTL,LH	NP	
	60-100000-2	WING INSTL,RH	NP	
- 1	R 60-100018-13	. DOOR,UPPER FWD LH&RH WING BOLT ACCESS/OUTBD/.	1	
- 2	R 60-100018-1	. DOOR,UPPER FWD LH&RH WING BOLT ACCESS/INBD/.	1	
- 3	R 60-100018-17	. DOOR ASSY,LWR FWD LH WING BOLT ACCESS	1	
	R 60-100018-18	. DOOR ASSY,LWR FWD RH WING BOLT ACCESS	1	
- 3A	R 35-105005-12	. DOOR ASSY,UPPER AFT LH WING BOLT ACCESS	1	
	R 35-105005-13	. DOOR ASSY,UPPER AFT RH WING BOLT ACCESS	1	
- 3B	R 60-100018-7	. DOOR ASSY,LWR AFT LH WING BOLT ACCESS	1	
	R 60-100018-8	. DOOR ASSY,LWR AFT RH WING BOLT ACCESS	1	
	R NAS1189-5P7N	. SCREW,DOOR HOLD DOWN.	1	
	R MS21208F5-20	. INSERT.	1	
	R 60-110000-605	. WING ASSY,LH/LESS FLAP,AILERON/SEE 57-10-01/.	1	1
	R 60-110000-606	. WING ASSY,RH/LESS FLAP,AILERON/SEE 57-10-01/.	1	1
	R 60-110000-607	. WING ASSY,LH/LESS FLAP,AILERON/SEE 57-10-02/.	1	2
	R 60-110000-608	. WING ASSY,RH/LESS FLAP,AILERON/SEE 57-10-02/.	1	2
		/ATTACHING PARTS/		
- 4	R MS21250-12022/M/ MS21250H12022/M/	. BOLT,WING ATTACH/UPPER FWD/	1	
		. BOLT,WING ATTACH/UPPER FWD/ALTERNATE/	1	
- 5	R 95-110021	. WASHER,UPPER FWD/UNDER BOLT HEAD/	1	
- 6	R 105090A032-12K	. WASHER,UPPER FWD/BETWEEN FITTINGS/.	1	
- 7	R 95-110025-1	. WASHER,UPPER FWD/UNDER NUT/	1	
- 8	R EB-126 ZEB1845-126	. NUT,UPPER FWD/ALTERNATE FOR ZEB1845-126/.	1	
		. NUT,UPPER FWD/ALTERNATE FOR EB-126/	1	
- 9	R MS21250-14034/M/ MS21250H14034/M/	. BOLT,WING ATTACH/LOWER FWD/	1	
		. BOLT,WING ATTACH/LOWER FWD/ALTERNATE/	1	
- 10	60-100020	. WASHER,LOWER FWD/UNDER BOLT HEAD/	1	
- 11	R 61475-14-43.5	. WASHER ASSY/SUPERSEDES BOTH 60-100019 WASHER. AND 60-100024 SPACER/	1	
- 12	R 72789-1414/M/	. NUT,LOWER FWD/SUPERSEDES 42FLW1414/	1	
- 13	R	. DELETED		
- 14	R	. DELETED		
- 15	R NAS150-38/M/ NAS150DH38/M/	. BOLT,WING ATTACH/UPPER AFT/	1	
		. BOLT,WING ATTACH/UPPER AFT/ALTERNATE/	1	
- 16	R 35-105111-3	. WASHER,UPPER AFT/UNDER BOLT HEAD/	1	
- 17	R 105090A032-10J	. WASHER,UPPER AFT/BETWEEN FITTINGS/.	1	
- 18	R 95-110025-3	. WASHER,UPPER AFT/UNDER NUT/	1	
- 19	R 12B108	. NUT,UPPER AFT	1	
- 20	R MS21250-12022/M/ MS21250H12022/M/	. BOLT,WING ATTACH/LOWER AFT/	1	
		. BOLT,WING ATTACH/LOWER AFT/ALTERNATE/	1	
- 21	R 95-110021	. WASHER,LOWER AFT/UNDER BOLT HEAD/	1	
- 22	R 60-100021	. WASHER,LOWER AFT/UNDER NUT/	1	
- 23	R EB-126 ZEB1845-126	. NUT,LOWER AFT/ALTERNATE FOR ZEB1845-126/.	1	
		. NUT,LOWER AFT/ALTERNATE FOR EB-126/	1	
- 24	R NAS1305-21	. BOLT,FWD/5TH ATTACH POINT/.	1	
- 25	R MS20002C5	. WASHER,FWD/5TH ATTACH POINT/.	1	
- 26	R 60-100011	. BUSHING,WING SHEAR TIE.	2	
- 27	R AN960D916L	. WASHER,FWD/5TH ATTACH POINT/.	AR	
- 28	R 60-100012	. SLIDE,WING SHEAR TIE.	1	
- 29	R AN960C516	. WASHER,FWD/5TH ATTACH POINT/.	1	
- 30	R MS20365-524C	. NUT,FWD/5TH ATTACH POINT/	1	

NOTE SEE BEECHCRAFT 60 MAINTENANCE MANUAL
AND BEECHCRAFT SERVICE INSTRUCTION NO.
1100 FOR INSTALLATION INSTRUCTIONS OF
61475-14-43 5 WASHER ASSY AND
72789-1414 NUT.

BEECHCRAFT
DUKE B60
ILLUSTRATED PARTS CATALOG

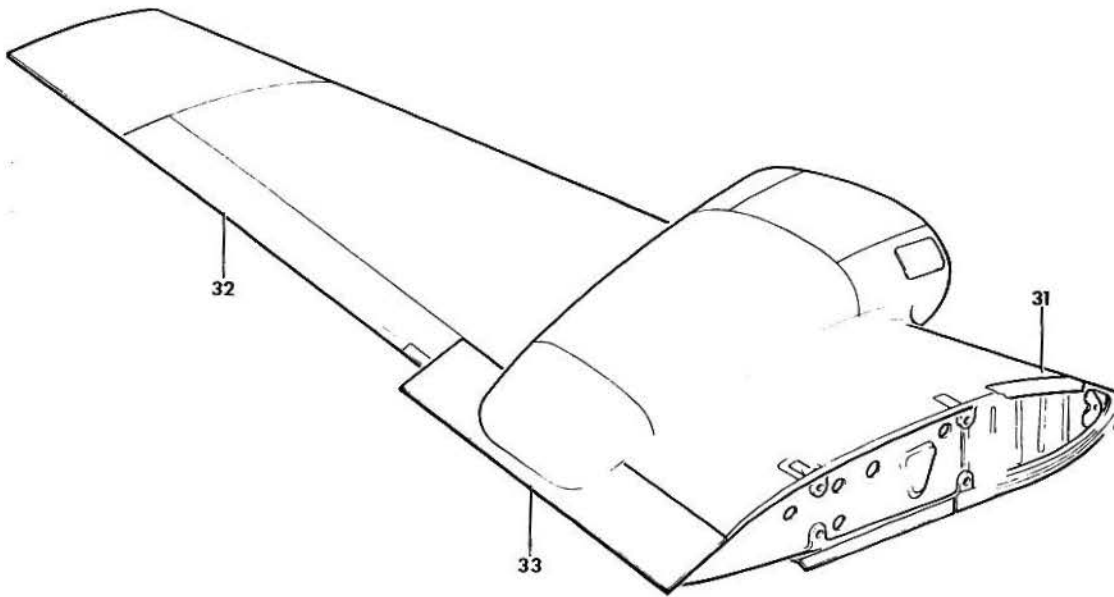
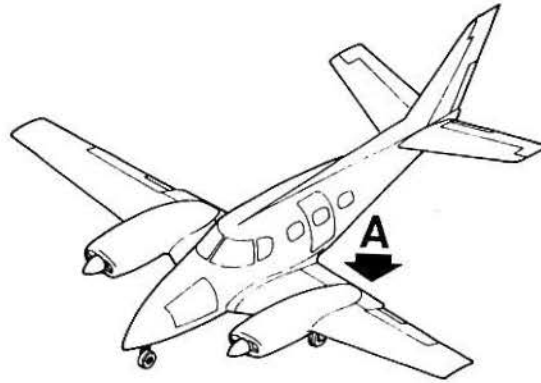

VIEW A

B60-31-6

B E E C H C R A F T
DUKE B60
I L L U S T R A T E D P A R T S C A T A L O G

SUB-SECT UNIT & ITEM NO.	PART NO.	DESCRIPTION							UNITS PER ASSY	USABLE ON CODE
		1	2	3	4	5	6	7		
40-01 - 31	R 60-100023-1	1	
	60-100023-2	1	
		/ATTACHING PARTS/								
	MS24693-48	10	
	NAS1329A08-160	10	
		*								
	60-100023-7	1	
	60-100023-8	1	
		/ATTACHING PARTS/								
	MS24693-48	10	
NAS1329A08-160	10		
	*									
- 32	R 60-130001-605	A	I	L	E	R	O	N	1	
	60-130001-163	A	I	L	E	R	O	N	1	
- 33	R 95-160000-609	F	L	A	P	A	S	S	1	
	95-160000-610	F	L	A	P	A	S	S	1	

C O D E S O F E F F E C T I V I T Y

1 P-247 THRU P-347, 2 P-348,
P-349 THRU P-364 P-365 AND AFTER

BEECHCRAFT
DUKE B60
ILLUSTRATED PARTS CATALOG

57-50-01
FLAPS

BEECHCRAFT
DUKE B60
ILLUSTRATED PARTS CATALOG

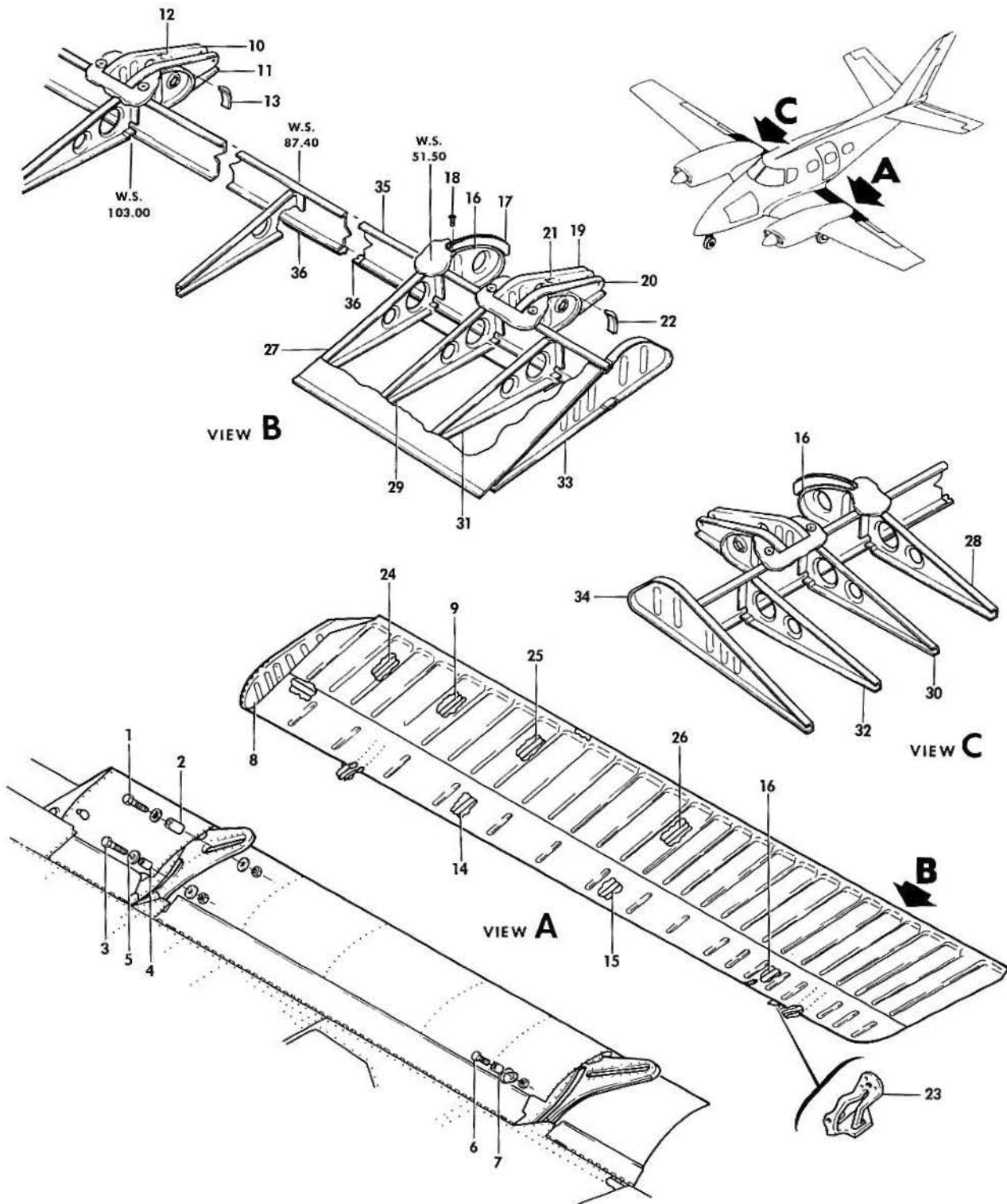

B60-40-2

B E E C H C R A F T
DUKE B60
I L L U S T R A T E D P A R T S C A T A L O G

GAMA/ATA CODE & INDEX NO.	PART NO.	DESCRIPTION	UNITS PER ASSY	USABLE ON CODE
		1 2 3 4 5 6 7		
50-01	95-160000-609	FLAP ASSEMBLY,LH.	1	
	95-160000-610	FLAP ASSEMBLY,RH.	1	
		/ATTACHING PARTS/		
- 1	130909823	BOLT,FLAP HINGE AFT	2	
- 2	BC22062	ROLLER,FLAP HINGE AFT	2	
- 3	130909821	BOLT,FLAP HINGE FWD	2	
- 4	35-165004	ROLLER,FLAP HINGE FWD	2	
- 5	50-105000-3	WASHER,TEFLON	2	
	AN960-10	WASHER.	4	
	130909N29	NUT	4	
- 6	130909838	BOLT,FLAP ACTUATOR.	1	
- 7	100801S5-0500	BUSHING,FLAP ACTUATOR	1	
	AN960-416	WASHER.	1	
	130909N32	NUT	1	

- 8	35-165050-76	. RIB,LH FLAP	1	
	35-165050-77	. RIB,RH FLAP	1	
- 9	95-160000-71	. RIB,LH FLAP	1	
	95-160000-72	. RIB,RH FLAP	1	
- 10	35-165050-34	. BRACKET,LEFT HALF OUTBD FLAP TRACK.	1	
- 11	35-160000-35	. BRACKET,RIGHT HALF OUTBD FLAP TRACK	1	
- 12	35-165050-65	. ANGLE,LEFT HALF OUTBD BRACKET	1	
- 13	35-165050-64	. ANGLE,RIGHT HALF OUTBD BRACKET.	1	
- 14	50-160012-3	. RIB,LH FLAP	1	
	50-160012-4	. RIB,RH FLAP	1	
- 15	50-160013-3	. RIB,LH FLAP	1	
	50-160013-4	. RIB,RH FLAP	1	
- 16	35-165050-84	. RIB,LH & RH	1	
- 17	35-165050-40	. BRACKET,FLAP ACTUATOR	1	
		/ATTACHING PARTS/		
- 18	AN520-10-8	. SCREW	3	
	100951S063ZT	. WASHER.	3	

- 19	35-165050-30	. BRACKET,LEFT HALF INBD FLAP TRACK	1	
- 20	35-165050-31	. BRACKET,RIGHT HALF INBD FLAP TRACK.	1	
- 21	35-165050-62	. ANGLE,LEFT HALF INBD BRACKET.	1	
- 22	35-165050-63	. ANGLE,RIGHT HALF INBD BRACKET	1	
- 23	95-160000-49	. CAM,FLAP LIMIT SWITCH 15 DEGREE/LH ONLY/.	1	
- 24	95-160000-25	. RIB,LH FLAP	1	
	95-160000-26	. RIB,RH FLAP	1	
- 25	95-160000-5	. RIB,LH FLAP	1	
	95-160000-6	. RIB,RH FLAP	1	
- 26	95-160000-9	. RIB,LH FLAP	1	
	95-160000-10	. RIB,RH FLAP	1	
- 27	95-160000-61	. RIB,LH FLAP	1	
- 28	95-160000-14	. RIB RH FLAP	1	
- 29	95-160000-22	. RIB,LH FLAP	1	
- 30	95-160000-64	. RIB,RH FLAP	1	
- 31	95-160000-32	. RIB,LH FLAP	1	
- 32	95-160000-66	. RIB,RH FLAP	1	
- 33	95-160000-67	. RIB,LH FLAP	1	
- 34	95-160000-68	. RIB,RH FLAP	1	
- 35	95-160000-73	. SPAR,LH FLAP.	1	
	95-160000-74	. SPAR,RH FLAP.	1	
- 36	95-160000-69	. STIFFENER,LH & RH	1	

BEECHCRAFT
DUKE B60
ILLUSTRATED PARTS CATALOG

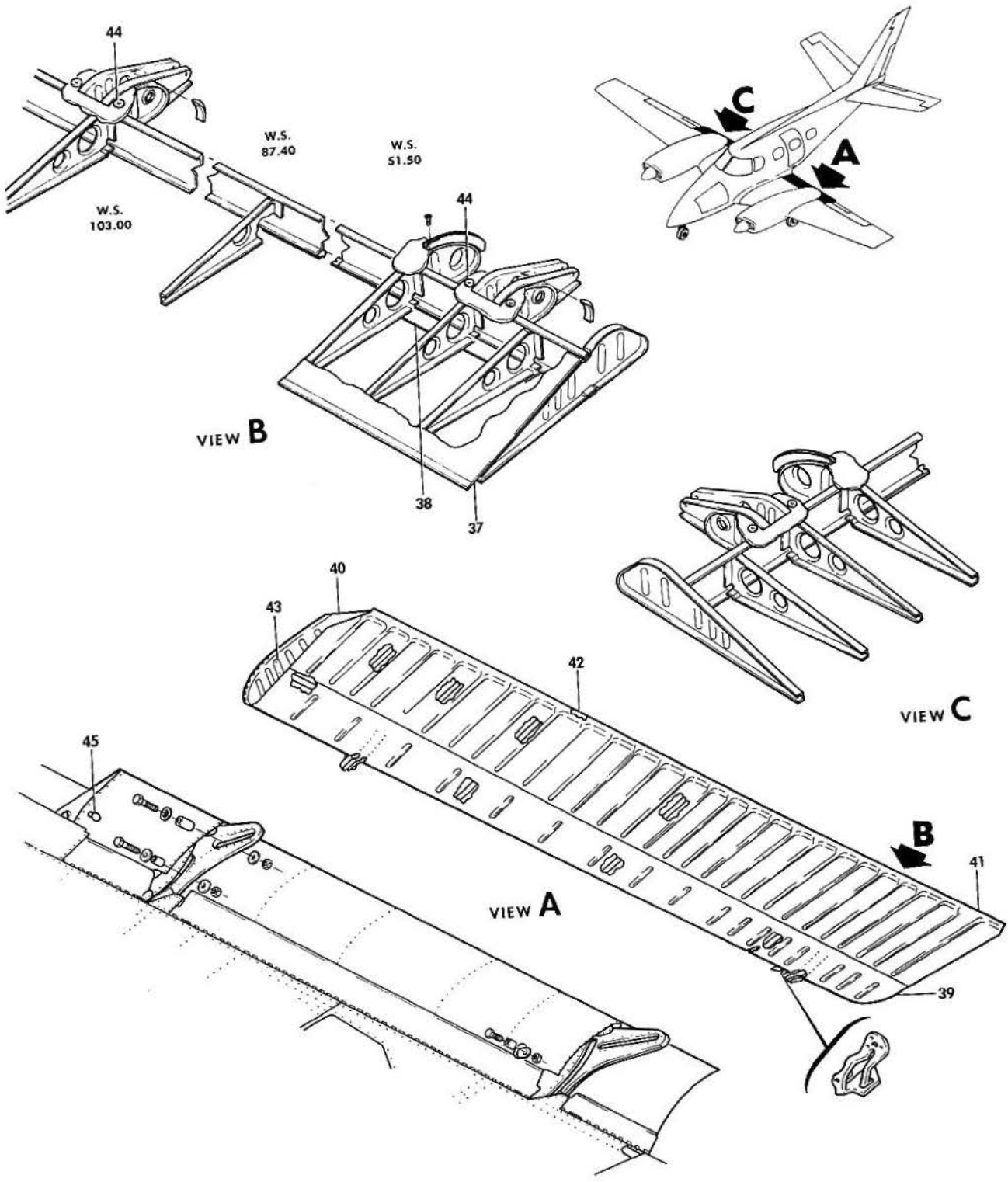

B60-40-3

B E E C H C R A F T
DUKE 860
I L L U S T R A T E D P A R T S C A T A L O G

GAMA/ATA CODE & INDEX NO.	PART NO.	DESCRIPTION							UNITS PER ASSY	USABLE ON CODE
		1	2	3	4	5	6	7		
50-01 - 37	95-160000-46	1	
- 38	95-160000-47	1	
- 39	95-160000-79	1	
	95-160000-80	1	
- 40	95-160000-33	1	
	95-160000-34	1	
- 41	95-160000-59	1	
	95-160000-78	1	
- 42	95-160000-57	1	
	95-160000-76	1	
- 43	103637	1	
		/ATTACHING PARTS/								
	49384	2	

- 44	A6914-1024-1	4	
- 45	2194	1	
		/ATTACHING PARTS/								
	AN515-8R18	1	
	105090CR32-3E	1	
	MS35649-282	1	

	MS25083-2AA6	1	

BEECHCRAFT
DUKE B60
ILLUSTRATED PARTS CATALOG

57-50-10
AILERON AND AILERON TAB

BEECHCRAFT
DUKE B60
ILLUSTRATED PARTS CATALOG

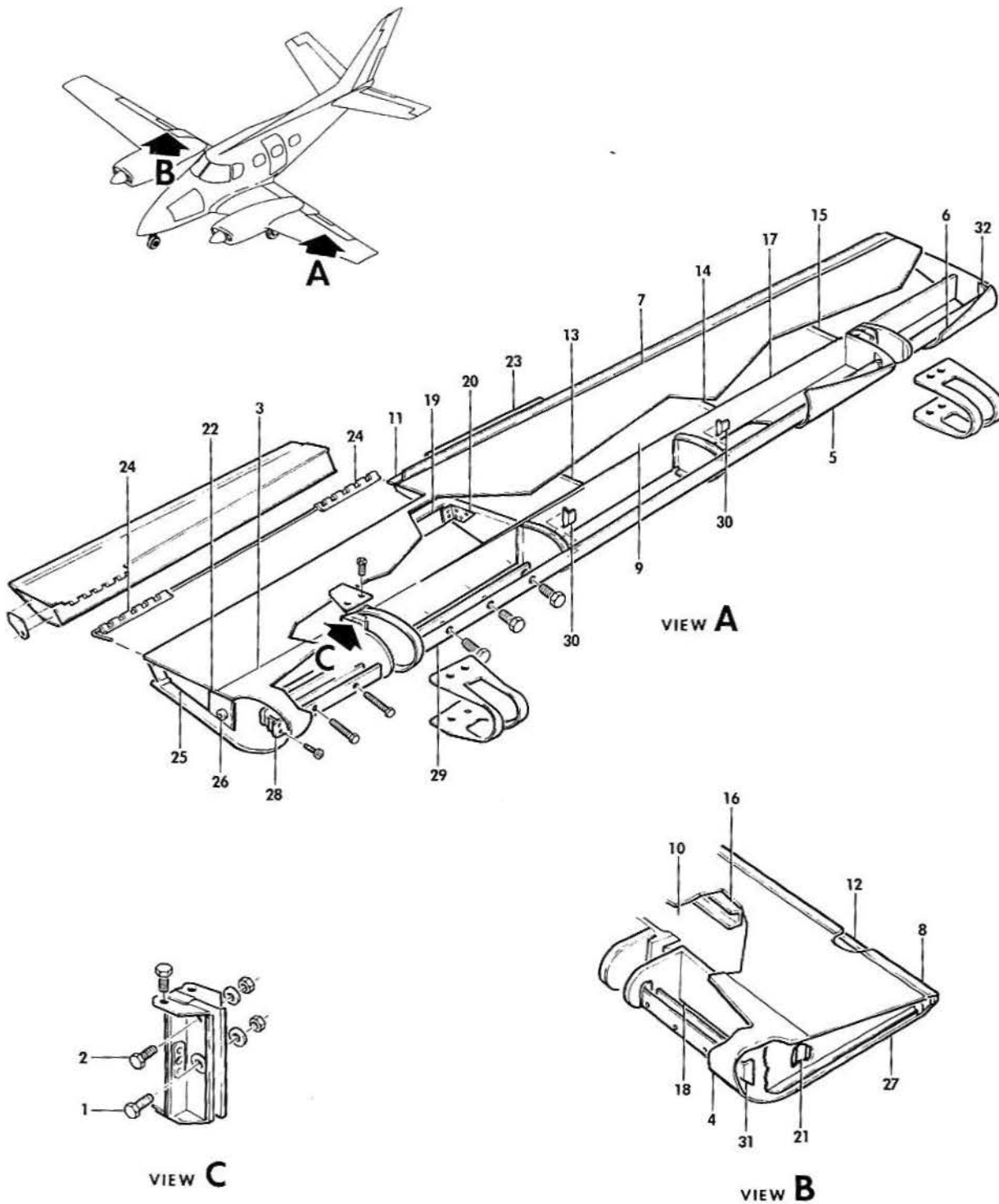

560-415

B E E C H C R A F T
DUKE B60
I L L U S T R A T E D P A R T S C A T A L O G

GAMA/ATA CODE & INDEX NO.	PART NO.	DESCRIPTION	UNITS PER ASSY	USABLE ON CODE
		1 2 3 4 5 6 7		
50-10	60-130001-605	AILERON ASSY,LH	1	
	60-130001-163	AILERON ASSY,RH	1	
		/ATTACHING PARTS/		
- 1	130909B20	BOLT,INBD HINGE	1	
	130909B19	BOLT,OUTBD HINGE	1	
	AN960-10	WASHER	2	
	130909N29	NUT	2	
- 2	AN174-10A/M/	BOLT,AILERON ACTUATOR ROD	1	
	AN960-416	WASHER	1	
	130909N32	NUT	1	
		-----*		
- 3	60-130001-95	. SKIN,LH FWD INBD	1	
- 4	60-130001-99	. SKIN,RH FWD INBD	1	
- 5	60-130001-93	. SKIN,LH & RH FWD CENTER	1	
- 6	60-130001-97	. SKIN,LH & RH FWD OUTBD	1	
- 7	60-130001-21	. SKIN,LH UPPER	1	
- 8	60-130001-25	. SKIN,RH UPPER	1	
- 9	60-130001-23	. SKIN,LH LOWER	1	
- 10	60-130001-27	. SKIN,RH LOWER	1	
- 11	60-130001-15	. SPACER,LH/BETWEEN 60-130001-21 & -23/	1	
- 12	60-130001-35	. SPACER,RH/BETWEEN 60-130001-25 & -27/	1	
- 13	60-130001-153	. STIFFENER,LH UPPER & LOWER/AIL STA 52.64/	2	
- 14	60-130001-155	. STIFFENER,LH UPPER & LOWER/AIL STA 64.75/	2	
- 15	60-130001-157	. STIFFENER,LH UPPER & LOWER/AIL STA 76.80/	2	
- 16	60-130001-159	. STIFFENER,RH ONLY/AIL STA 16.7 TO STA 78.2/	1	
- 17	60-130001-5	. SPAR,LH AILERON FWD	1	
- 18	60-130001-33	. SPAR,RH AILERON	1	
- 19	60-130015	. SPAR,LH AILERON REAR	1	
- 20	60-130001-29	. ANGLE,LH AILERON REAR SPAR SUPPORT	1	
- 21	60-130001-39	. ANGLE,RH AILERON SPAR SUPPORT	1	
- 22	60-130001-11	. ANGLE,LH AILERON FWD SPAR SUPPORT	1	
- 23	60-130001-131	. TAB,STATIONARY/LH & RH AILERON/	1	
- 24	60-130001-13	. HINGE,LH AILERON TRIM TAB HALF	1	
	60-130013-11	. RIB ASSY,LH AILERON INBD	1	
- 25	60-130013-13	. . RIB	1	
	60-130013-3	. . DOUBLER	1	
	MS21078-3	. . NUTPLATE	1	
- 26	60-130018	. . PIVOT ASSY,TRIM TAB ACTUATOR	1	
	60-130018-5	. . BUSHING	1	
- 27	60-130016-3	. RIB,RH AILERON INBD	1	
	60-130001-113	. CLIP ASSY,LH AILERON	1	
- 28	60-130001-115	. . CLIP,LH RIB	1	
	AN366F1032	. . NUTPLATE	1	
	60-130001-111	. CLIP ASSY,LH & RH AILERON	3	
		/ATTACHING PARTS/		
	130909B14	. BOLT	1	
		-----*		
- 29	60-130001-119	. . CLIP	3	
	AN366F1032	. . NUTPLATE	3	
- 30	60-130001-119	. CLIP	2	
	60-130001-127	. CLIP ASSY,AILERON/1 LH & 2 RH/	2	
		/ATTACHING PARTS/		
	130909B14	. BOLT	1	
		-----*		
- 31	60-130001-129	. . CLIP/1 LH & 2 RH/	2	
	AN366F1032	. . NUTPLATE	2	
	60-130001-109	. CLIP ASSY,LH & RH AILERON	1	
		/ATTACHING PARTS/		
	130909B14	. BOLT	1	
		-----*		
- 32	60-130001-117	. . CLIP	1	
	AN366F1032	. . NUTPLATE	1	

BEECHCRAFT
DUKE B60
ILLUSTRATED PARTS CATALOG

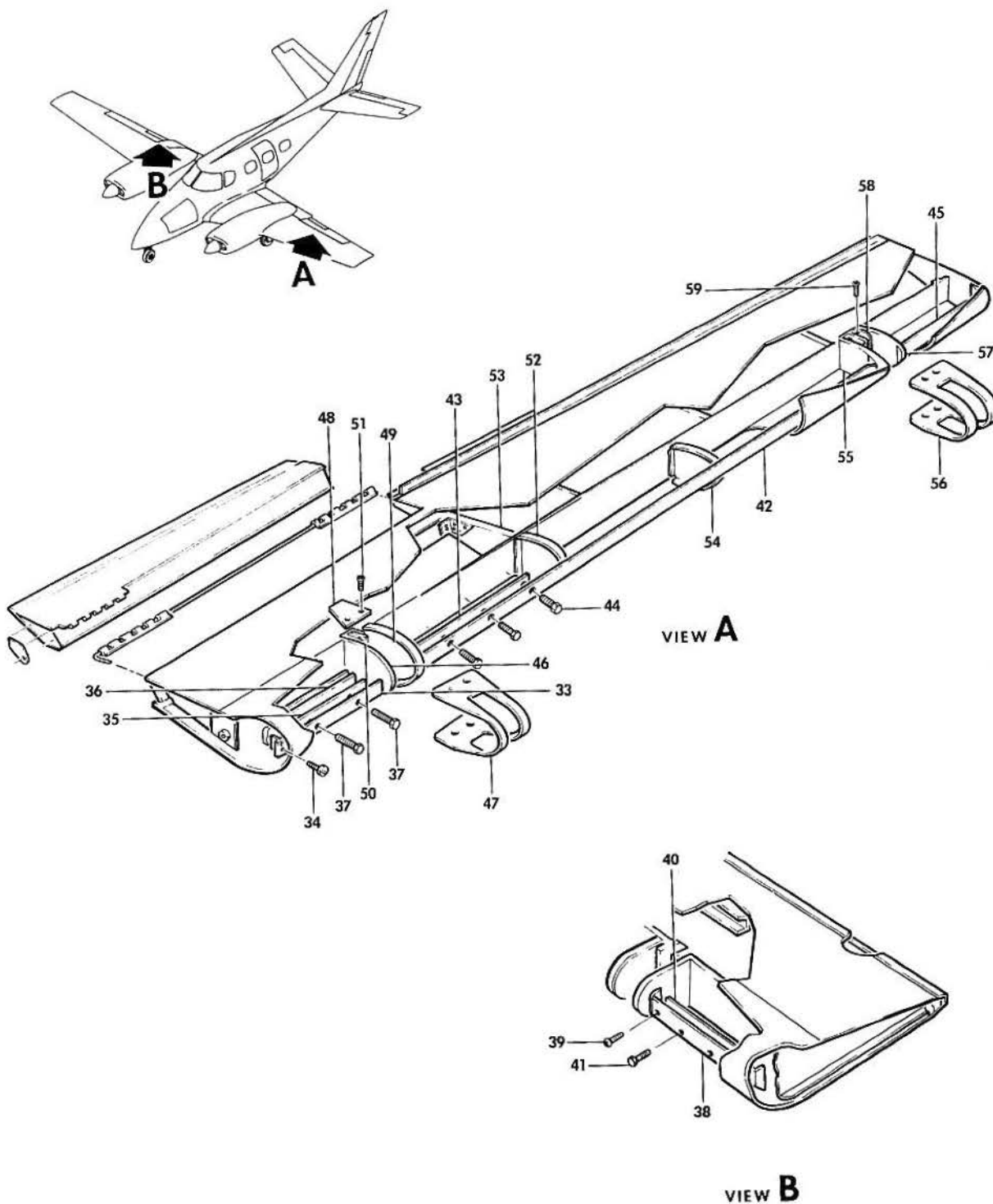

B60 41 6

B E E C H C R A F T
DUKE 860
I L L U S T R A T E D P A R T S C A T A L O G

GAMA/ATA CODE & INDEX NO.	PART NO.	DESCRIPTION	1 2 3 4 5 6 7							UNITS PER ASSY	USABLE ON CODE
			1	2	3	4	5	6	7		
50-10 - 33	60-130001-17	. WEIGHT,LH AILERON INBD BALANCE.								1	
		/ATTACHING PARTS/									
- 34	AN525-10-10	. SCREW								4	
	AN960-10	. WASHER.								4	
	130909N29	. NUT								4	
		*									
- 35	60-130001-121	. WEIGHT,LH AILERON INBD BALANCE.								1	
- 36	60-130001-103	. WEIGHT,LH AILERON INBD BALANCE.								2	
		/ATTACHING PARTS/									
- 37	130909B41	. BOLT.								2	
	AN960-416	. WASHER.								2	
	130909N32	. NUT								2	
		*									
- 38	60-130001-41	. WEIGHT,RH AILERON INBD BALANCE.								1	
		/ATTACHING PARTS/									
- 39	AN525-10-10	. SCREW								4	
	AN960-10	. WASHER.								4	
	130909N29	. NUT								4	
		*									
- 40	60-130001-103	. WEIGHT,RH AILERON INBD BALANCE.								1	
		/ATTACHING PARTS/									
- 41	130909B36	. BOLT.								2	
	AN960-416	. WASHER.								2	
	130909N32	. NUT								2	
		*									
- 42	60-130001-125	. WEIGHT,LH & RH AILERON CENTER BALANCE								1	
- 43	60-130001-123	. WEIGHT,LH AILERON CENTER BALANCE.								2	
		/ATTACHING PARTS/									
- 44	130909B36	. SCREW								3	
	AN960-416	. WASHER.								3	
	130909N32	. NUT								3	
		*									
- 45	99-130000-117	. WEIGHT,LH & RH AILERON OUTBD BALANCE.								1	
	60-130001-107	. RIB ASSY,LH & RH AILERON.								1	
- 46	60-130001-77	. RIB,LH & RH								1	
	MS21047-08K	. NUTPLATE.								1	
- 47	60-130001-89	. DOUBLER,LH & RH AILERON								1	
- 48	99-130000-121	. DOUBLER,LH & RH AILERON								2	
- 49	60-130001-79	. RIB,LH & RH AILERON								1	
- 50	60-130019-13	. HINGE ASSY,LH & RH AILERON INBOARD.								1	
		/ATTACHING PARTS/									
- 51	AN525-10R9	. SCREW								4	
	AN366F1032	. NUTPLATE.								4	
		*									
	60-130019-11	. WELD ASSY,HINGE								1	
	100-130010	. PIN,SHEAR								1	
- 52	60-130001-81	. RIB,LH & RH AILERON								1	
- 53	60-130014	. RIB,LH AILERON.								1	
- 54	60-130001-83	. RIB,LH & RH AILERON								1	
- 55	60-130001-85	. RIB,LH & RH AILERON								1	
- 56	60-130001-91	. DOUBLER,LH & RH AILERON								1	
	60-130001-105	. RIB ASSY,LH & RH AILERON.								1	
- 57	60-130001-87	. RIB,LH & RH AILERON								1	
	MS21047-08K	. NUTPLATE.								1	
- 58	60-130020	. HINGE ASSY,LH & RH AILERON OUTBOARD								1	
		/ATTACHING PARTS/									
- 59	AN525-10R8	. SCREW								4	
	AN366F1032	. NUTPLATE.								4	
		*									
	60-130020-5	. WELD ASSY,HINGE								1	
	100-130010	. PIN,SHEAR								1	

BEECHCRAFT
DUKE B60
ILLUSTRATED PARTS CATALOG

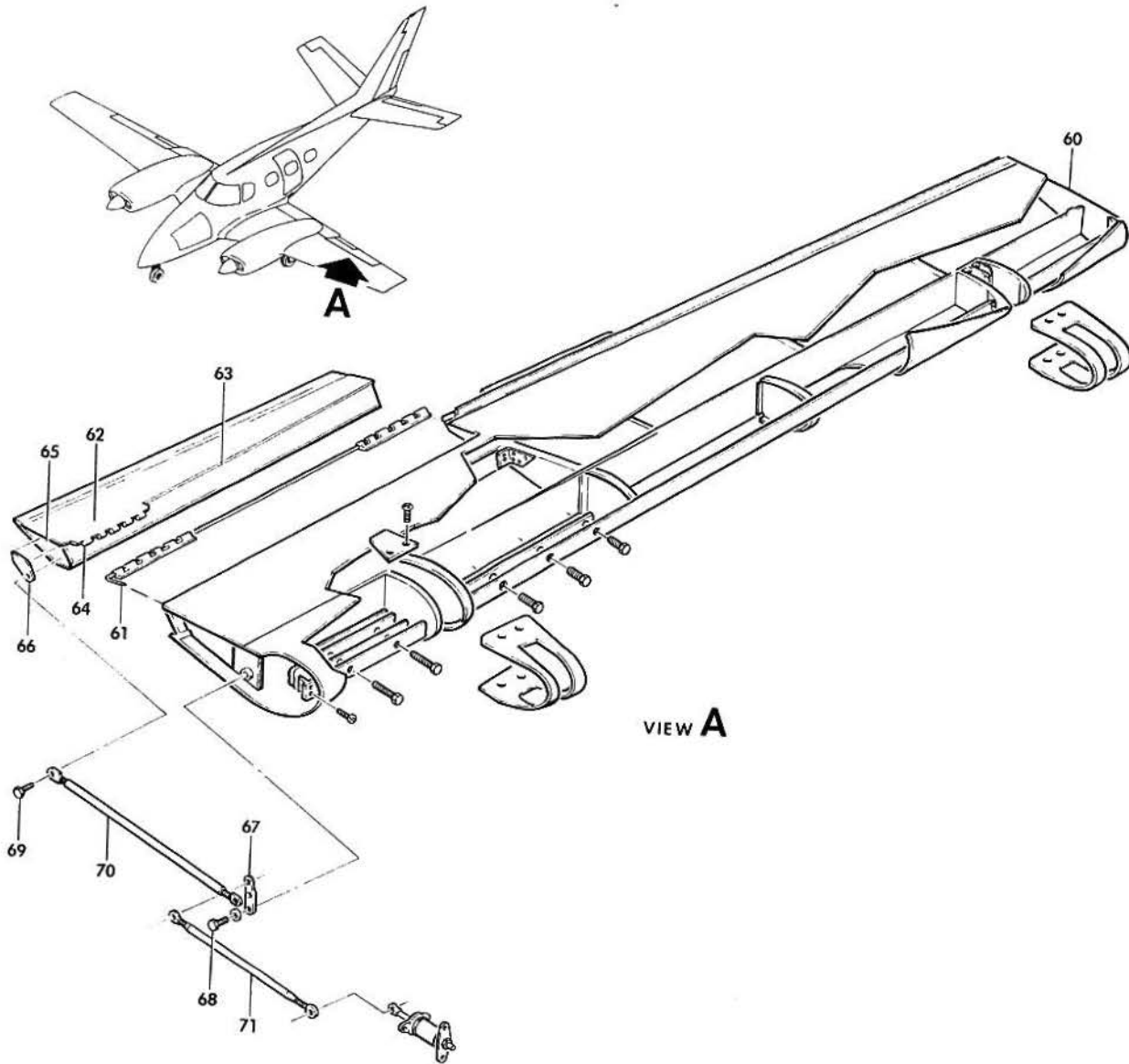

B60 41.7

B E E C H C R A F T
DUKE B60
I L L U S T R A T E D P A R T S C A T A L O G

GAMA/ATA CODE & INDEX NO.	PART NO.	1 2 3 4 5 6 7	DESCRIPTION	UNITS PER ASSY	USABLE ON CODE
50-10 - 60	60-130001-75	.	RIB,LH AILERON OUTBOARD	1	
	60-130001-76	.	RIB,RH AILERON OUTBOARD	1	
	60-130011	.	TAB ASSY,LH AILERON TRIM.	1	
	/ATTACHING PARTS/				
- 61	60-130001-19	.	PIN,HINGE	1	

	60-130011-1	.	SKIN,LOWER.	1	
- 62	60-130011-3	.	SKIN,UPPER.	1	
- 63	60-130011-5	.	SPAR,LH AILERON TRIM TAB.	1	
- 64	60-130011-7	.	HINGE,TRIM TAB HALF	1	
	60-130011-601	.	RIB ASSY,TRIM TAB	1	
- 65	60-130011-11	.	RIB	1	
- 66	60-130011-9	.	PLATE,BUSHING	1	
	105740XZL0110	.	BUSHING/PRESS FIT IN 60-130011-9/	1	
- 67	60-521017	.	LINK,TRIM TAB ACTUATOR.	1	
	/ATTACHING PARTS/				
- 68	AN173-13A/M/ AN960-10	.	BOLT.	1	
	AN960-616	.	WASHER.	1	
	60-524092-3	.	WASHER.	1	

	60-521021	.	TUBE ASSY,TRIM TAB ACTUATOR	1	
	/ATTACHING PARTS/				
- 69	AN174-5/M/ AN174-6	.	BOLT.	1	
	AN960-416L	.	BOLT.	1	
	AN960-416	.	WASHER.	1	
	130909N7	.	WASHER.	3	
	AN380-2-3	.	NUT	2	

- 70	60-521021-1	.	TUBE.	1	
	60-521022-3	.	END,AFT ROD	1	
	60-521022-1	.	END,FWD ROD	1	
	AN316-4R	.	NUT,CHECK	2	
- 71	60-521019-1	.	TUBE,TRIM TAB ACTUATOR.	1	
	60-521014-5	.	ROD ASSY,AILERON CONTROL PUSH	1	

