

B E E C H C R A F T  
DUKE B60  
I L L U S T R A T E D P A R T S C A T A L O G

LIST OF PAGES & TABLE OF CONTENTS  
FOR  
CHAPTER 78-00-00 EXHAUST

SYS/SUB-SYS/ CHAP SECTION	PAGE NO.	EFFECTIVE DATE	TABLE OF CONTENTS
78-00-00	1	03/20/81.	. . . . LIST OF PAGES & TABLE OF CONTENTS . . . . .
78-10-10	1	03/20/81.	. . . . EXHAUST ASSEMBLY. . . . .
78-10-10	2	03/20/81	
78-10-10	3	03/20/81	



BEECHCRAFT  
DUKE B60  
ILLUSTRATED PARTS CATALOG

78-10-10  
EXHAUST ASSEMBLY

BEECHCRAFT  
DUKE B60  
ILLUSTRATED PARTS CATALOG

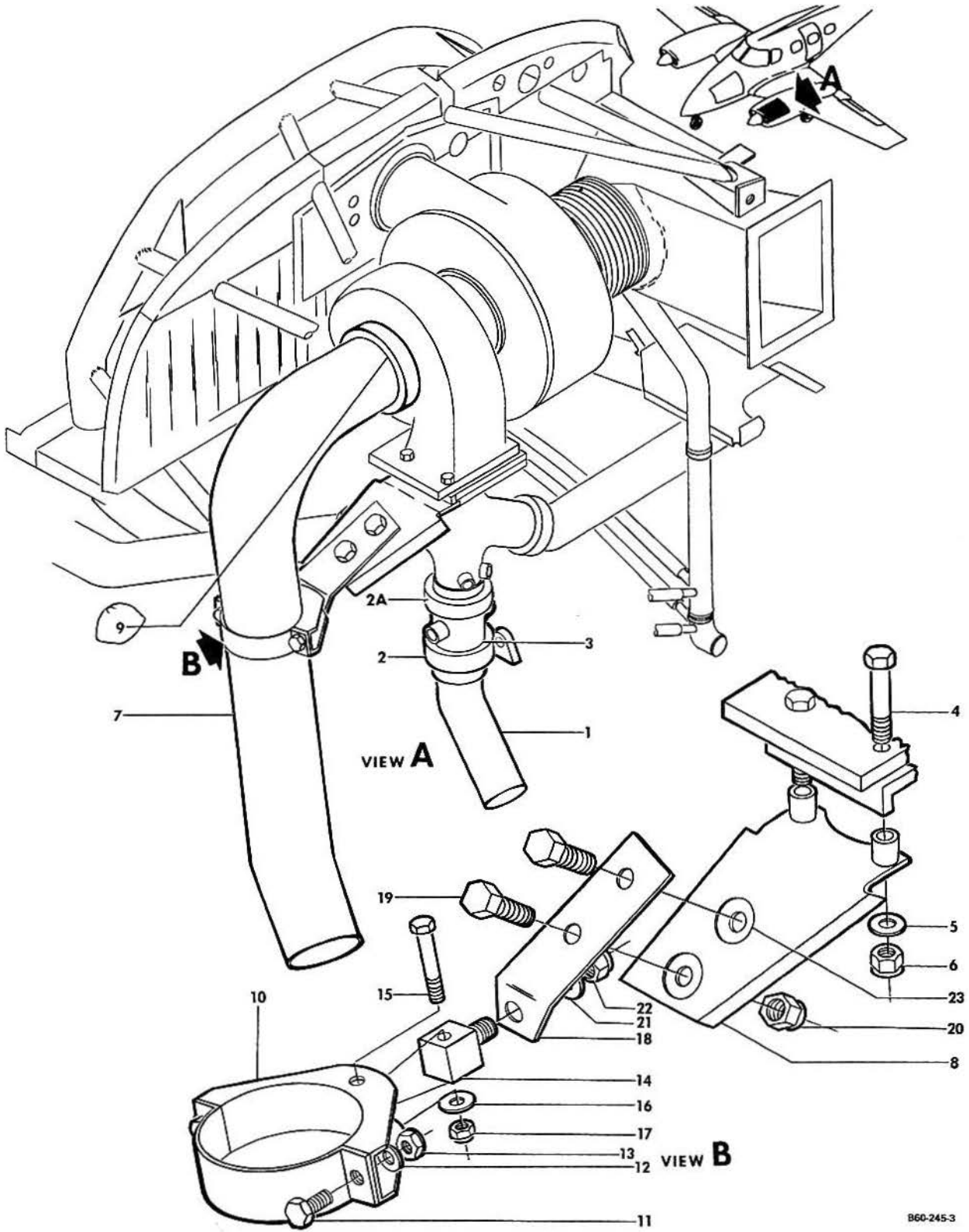

B E E C H C R A F T  
DUKE B60  
I L L U S T R A T E D P A R T S C A T A L O G

GAMA/ATA CODE & INDEX NO.	PART NO.	DESCRIPTION	UNITS PER ASSY							USABLE ON CODE	
			1	2	3	4	5	6	7		
10-10 - 1	60-950027-7	STACK ASSY, EXHAUST WASTE GATE . . . . .								1	
		/ATTACHING PARTS/									
- 2	LW12125-3	COUPLING, UPPER. . . . .								1	
- 2A	LW12093-5	COUPLING, LOWER. . . . .								1	
		*-----*									
- 3	24096-225-M	. GASKET. . . . .								1	
	60-950024-17	STACK ASSY, EXHAUST TURBOCHARGER . . . . .								1	
		/ATTACHING PARTS/									
- 4	AN6C20A	BOLT. . . . .								2	
- 5	AN960C616	WASHER. . . . .								2	
- 6	MS20365-624C	NUT . . . . .								2	
		*-----*									
- 7	60-950024-13	. TUBE ASSY . . . . .								1	
- 8	60-950026-25	. BRACKET ASSY. . . . .								1	
- 9	MVT68637-450M	CLAMP . . . . .								1	
	60-950026-23	SUPPRT INSTL, EXHAUST MOUNTING. . . . .								NP	
- 10	60-950026-3	. CLAMP . . . . .								1	
		/ATTACHING PARTS/									
- 11	AN5C6A	. BOLT. . . . .								2	
- 12	AN960C516	. WASHER. . . . .								2	
- 13	MS20365-524C	. NUT . . . . .								2	
- 14	60-950026-1	. NUT, PIVOT . . . . .								1	
- 15	AN6C16	. BOLT. . . . .								1	
- 16	AN960C616	. WASHER. . . . .								1	
- 17	MS20365-624C	. NUT . . . . .								1	
		*-----*									
- 18	60-950026-11	. ANGLE . . . . .								1	
		/ATTACHING PARTS/									
- 19	AN7-10A	. BOLT/CUT AND THREAD AS REQUIRED/. . . . .								2	
- 20	MS20365-720C	. NUT . . . . .								2	
- 21	AN960C816	. WASHER. . . . .								1	
- 22	MS20365-820C	. NUT . . . . .								1	
		*-----*									
- 23	60-950026-21	. PLATE . . . . .								1	

NOTE FOR EXHAUST MANIFOLD CALLOUT SEE LYCOMING ENGINE MANUAL

506-053 ✓  
 2274-60 ✓  
 MS 68637-450M  
 NH 1000 89750  
 506-053  
 2274-60

