

# 27 Flight Controls



**Beechcraft**  
**DUKE 60 SERIES**  
**MAINTENANCE MANUAL**

**CHAPTER 27**  
**RECORD OF TEMPORARY REVISIONS**

REVISION NUMBER	DATE INSERTED	DATE REMOVED	REASON REMOVED	PAGE NUMBER
27-1	Dec 11/92	Nov 15/93	Temporary Revision 27-2	27-50-00 Page 203
27-2	Nov 15/93			27-50-00 Page 203

**NOTE:** Insert this Record of Temporary Revisions after the Chapter 27 divider tab.



BEECHCRAFT  
DUKE 60 SERIES  
MAINTENANCE MANUAL

CHAPTER 27

LIST OF PAGE EFFECTIVITY

CHAPTER SECTION SUBJECT	PAGE	DATE
27-EFFECTIVITY	1	Sep 20/85
27-CONTENTS	1 2	Sep 20/85 Sep 20/85
27-00-00	1 201 202	Nov 2/73 Nov 2/73 Nov 2/73
27-10-00	201 202 203 204 205	Nov 2/73 Nov 2/73 Sep 14/79 Sep 14/79 Sep 14/79
27-20-00	201 202 203 204 205	Nov 2/73 Nov 2/73 Nov 2/73 Sep 14/79 Sep 14/79
27-30-00	201 202 203 204 204A 205 206 207	Sep 20/85 May 30/75 Sep 20/85 Sep 20/85 Sep 20/85 Sep 14/79 Sep 14/79 Sep 14/79
27-50-00	1 201 202 203	Nov 2/73 Nov 2/73 Nov 2/73 Nov 2/73
27-60-00	1 101 201	Nov 2/73 Nov 2/73 Nov 2/73
27-70-00	201	Nov 2/73

"END"



**BEECHCRAFT  
DUKE 60 SERIES  
MAINTENANCE MANUAL**

**CHAPTER 27 - FLIGHT CONTROLS**

*TABLE OF CONTENTS*

<b>SUBJECT</b>	<b>CHAPTER SECTION SUBJECT</b>	<b>PAGE</b>
<b>GENERAL</b>	27-00-00	
Description and Operation		1
Effect of Temperature Upon Cable Tension		1
Maintenance Practices		1
Control Column		201
Bus Cable Removal		201
Bus Cable Installation		202
Bus Cable Rigging		202
		202
<b>AILERON AND TAB</b>	27-10-00	201
Maintenance Practices		201
Aileron Removal		201
Aileron Installation		201
Aileron Control Cable Removal		201
Aileron Control Cable Installation		201
Aileron Control System Rigging		201
Trim Tab Cable Removal		201
Trim Tab Cable Installation		203
Trim Tab Rigging		203
Trim Tab Actuator Removal		203
Trim Tab Actuator Installation		203
Checking Trim Tab Free Play		203
<b>RUDDER AND TAB</b>	27-20-00	201
Maintenance Practices		201
Rudder Removal		201
Rudder Installation		201
Rudder Cable Removal		201
Rudder Cable Installation		201
Rudder Control System Rigging		201
Trim Tab Cable Removal		203
Trim Tab Cable Installation		203
Trim Tab Rigging		203
Trim Tab Actuator Removal		203
Trim Tab Actuator Installation		204
Checking Trim Tab Free Play		204
<b>ELEVATOR AND TAB</b>	27-30-00	201
Maintenance Practices		201
Elevator Removal		201
Elevator Installation		201
Elevator Cable Removal		201
Elevator Cable Installation		201
Elevator Control System Rigging		201
Trim Tab Cable Removal		203
Trim Tab Cable Installation		204

**BEECHCRAFT  
DUKE 60 SERIES  
MAINTENANCE MANUAL**

**CHAPTER 27 - FLIGHT CONTROLS**

*TABLE OF CONTENTS (Cont'd)*

<b>SUBJECT</b>	<b>CHAPTER SECTION SUBJECT</b>	<b>PAGE</b>
<b>ELEVATOR AND TAB</b>	<b>27-30-00</b>	
Maintenance Practices (Cont'd)		
Trim Tab Rigging		204
Trim Tab Actuator Removal		204A
Trim Tab Actuator Installation		204A
Electric Trim Tab Actuator Removal		204A
Electric Trim Tab Actuator Installation		204A
Electric Trim Tab Cable Installation		204A
Electric Trim Tab Actuator Magnetic Clutch Removal		205
Electric Trim Tab Actuator Magnetic Clutch Installation		205
Electric Trim Tab Actuator Magnetic Clutch Torque Test		205
Checking Trim Tab Free Play		206
<b>FLAPS</b>	<b>27-50-00</b>	1
Description and Operation		1
Maintenance Practices		201
Flap Removal		201
Flap Installation		201
Flap Track Roller Installation		201
Control System Rigging		201
Functional Ground Test		201
Position Transmitter Adjustment (P-4 through P-246)		201
Position Indicator Lights Adjustment and Functional Test (P-247 and after)		203
Actuator Removal		203
Actuator Installation		203
Motor/Gearbox Removal		203
Motor/Gearbox Installation		203
<b>STALL WARNING SYSTEM</b>	<b>27-60-00</b>	1
Description and Operation		1
Troubleshooting		101
Maintenance Practices		201
Stall Warning Indicator Removal		201
Stall Warning Indicator Installation		201
Stall Warning Indicating System Adjustment		201
<b>GUST LOCK</b>	<b>27-70-00</b>	201
Maintenance Practices		201

"END"



**BEECHCRAFT  
DUKE 60 SERIES  
MAINTENANCE MANUAL**

**GENERAL - DESCRIPTION AND OPERATION**

The flight controls, with the exception of the flaps, are conventional cable operated surfaces requiring no power assistance for normal control by the pilot or copilot. The aileron, elevator, and rudder have cable operated flight adjustable trim tabs. The flaps have electrically powered actuators controlled by a switch on the subpanel.

Positive stops on the control surface bell cranks limit their travel, while travel stops secured on the tab cables limit the trim tab movement.

Since the control cables can be disconnected at the turnbuckles, each cable has one right hand and one left

hand threaded cable end. Cable routing off the pedestal, control column and actuator drums is shown in Figure 201 of 27-10-00, 27-20-00, and 27-30-00.

*EFFECT OF TEMPERATURE UPON CABLE TENSION*

Graphs specifying the correct maximum and minimum cable tension permissible for the various controls appear on the individual rigging control system illustrations. The graphs provide rigging limits at temperatures varying from 30° to 110° F. The horizontal scale on the graphs designates the temperature in degrees fahrenheit at which the control cables may be rigged, and the vertical scale designates the correct tension in pounds for each temperature reading.

**"END"**



**BEECHCRAFT  
DUKE 60 SERIES  
MAINTENANCE MANUAL**

**GENERAL - MAINTENANCE PRACTICES**

**CONTROL COLUMN**

(Figure 201)

Refer to the applicable rigging procedures for details

regarding chain and cable tension, control wheel movement and force, and system friction. Any time the control column has been removed and disassembled, the following

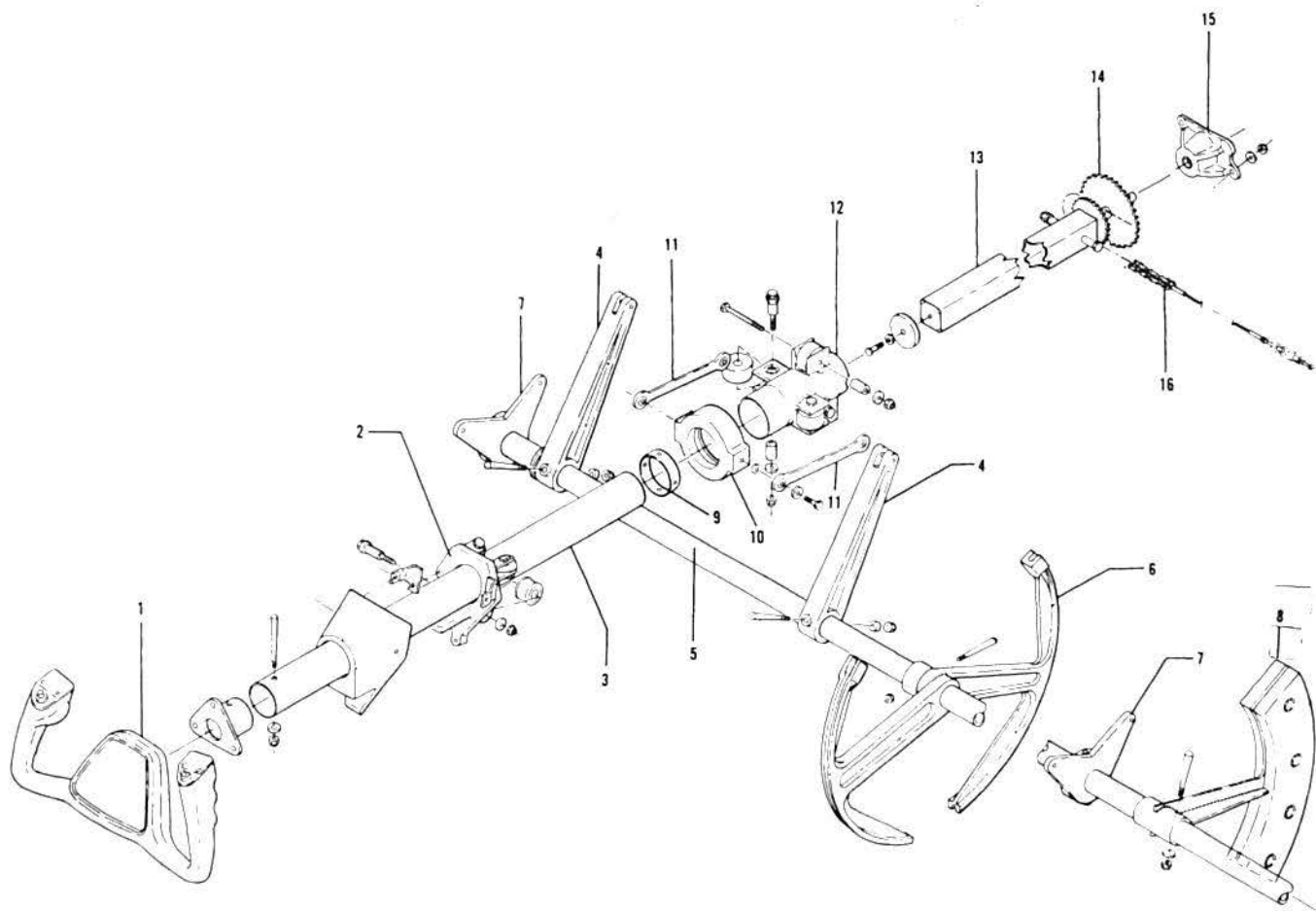

60-155-2

- |                                 |                       |
|---------------------------------|-----------------------|
| 1. Wheel                        | 9. Collar             |
| 2. Collar Assembly              | 10. Collar Assembly   |
| 3. Column Torque Tube           | 11. Elevator Push Rod |
| 4. Elevator Torque Arm          | 12. Connector         |
| 5. Elevator Torque Tube         | 13. Inner Column      |
| 6. Elevator Bell Crank          | 14. Sprocket          |
| 7. Elevator Torque Tube Support | 15. Bearing Support   |
| 8. Bob Weight Assembly          | 16. Chain             |

**Control Column  
Figure 201**

**BEECHCRAFT  
DUKE 60 SERIES  
MAINTENANCE MANUAL**

precautions should be observed:

a. When the taper pin just forward of the control wheel is to be installed, use a light weight rawhide or nylon mallet to set the pin. The small end of the tapered shank should be flush with, or extend no more than .06 inch over the surface.

**CAUTION**

The taper pin may crack the control column torque tube if driven excessively.

b. The procedure noted above shall apply to the taper pins used to install the torque arms and the bob weight assembly.

c. When installing the torque tube guide, apply thread locking compound (36, Chart 207, 91-00-00) to bolt threads prior to installation.

**CONTROL COLUMN BUS CABLE REMOVAL**

a. Disconnect the aileron cables from the control column at the turnbuckles.

b. Paint one tooth of each of the control column sprockets and its corresponding chain link to ensure proper alignment of the control wheels at installation.

c. Loosen the cable turnbuckle in the center of the control column horizontal cross member. Remove safety wire from the chains and sprockets. Remove the cable and chain assembly.

**CONTROL COLUMN BUS CABLE INSTALLATION**

a. Install the control column bus cable and chain assembly on the cross member of the control column with the painted links of the chains engaging the corresponding sprocket teeth.

b. Rig the control column bus cable and safety wire the chain to the sprockets as shown in Figure 202.

c. Rig the aileron control cable. (Refer to 27-10-00).

**CONTROL COLUMN BUS CABLE RIGGING**  
(Figure 202)

Rigging of the control column bus cable can be accomplished by adjusting the bus cable turnbuckles to obtain a  $.25 \pm .05$  inch deflection with a load of  $2 \pm .5$  pounds applied at a right angle, 4 to 5 inches to the left of the aircraft center line as shown in Figure 202.

**NOTE**

When final adjustment of the bus cable is established, the pilot and copilot control wheels should be in neutral position.

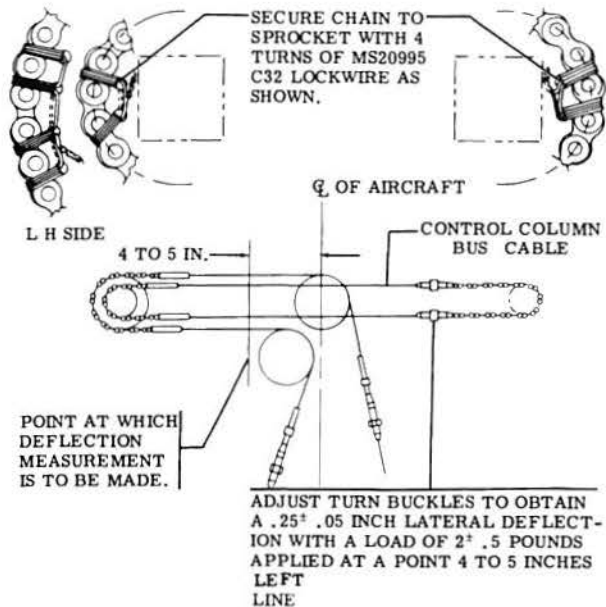

**Control Column Bus Cable Adjustment**  
**Figure 202**

"END"

**BEECHCRAFT  
DUKE 60 SERIES  
MAINTENANCE MANUAL**

## **AILERON AND TAB - MAINTENANCE PRACTICES**

### ***AILERON REMOVAL***

- a. Disconnect the aileron tab push rod.
- b. Support the aileron and remove the two attaching screws from the top and bottom of each hinge bracket.
- c. Pull the aileron straight away from the wing to avoid damage to the attaching areas.
- d. Remove the screws attaching the bonding cables to the aileron.

### ***AILERON INSTALLATION***

- a. Attach the bonding cables to the aileron.
- b. Place the aileron in position on the hinge brackets. Be sure the hinge bracket is in the proper place between the aileron skin and the reinforcing structure.
- c. Install the upper and lower hinge bracket screws.
- d. Connect the aileron tab push rod.

### ***AILERON CONTROL CABLE REMOVAL*** (Figure 201)

- a. Remove the pilot's and copilot's seat, and the floorboards in the pilot's compartment.
- b. Remove the forward passenger seats and the floorboards between the main and rear spar.
- c. Remove the access plates, as necessary to gain access to the aileron cables and pulley brackets, on the lower trailing edge of the wings.
- d. Remove all necessary cable retaining pins from the cable pulley brackets. Remove the pressure seals on each side of the fuselage.
- e. Disconnect the forward aileron cables from the chain and cable assembly at the turnbuckles at the control column. Install lead lines to both aileron cables.
- f. Paint one tooth of the control column sprocket and the corresponding link of the chain and cable assembly to insure proper alignment at installation.
- g. Disconnect the forward aileron cables and the forward outboard wing cable at the turnbuckles in each wing. Identify and remove both forward cables.
- h. Disconnect the balance cable at the turnbuckle in each wing. Connect a lead line to one end of the cable and remove the cable.
- i. Disconnect the forward outboard, and the aft outboard cables at the bell crank in each wing. Identify and remove the cables.

### ***AILERON CONTROL CABLE INSTALLATION***

- a. Connect the forward outboard, and the aft outboard cables to the bell crank in each wing. Route the cables inboard.
- b. Route the balance cable through one wing, the

fuselage, then through the opposite wing. Connect the balance cable and the aft outboard cables to the turnbuckles in each wing.

- c. Route one end of the aileron cables outboard in each wing, and the other end forward to the control column. Connect the cables to the turnbuckles at the forward outboard cable in each wing.
- d. Position the chain and cable assembly on the control column sprocket. Ensure that painted link and the corresponding painted tooth are aligned.
- e. Connect the chain and cable assembly to both aileron cables at the turnbuckles at the control column.
- f. Install all retaining pins in the pulley brackets.
- g. Using PD680 solvent (15, Chart 207, 91-00-00), clean the cables for the length of travel through the pressure seals. Lubricate to one inch beyond the cleaned area with MIL-G-23827 grease (11, Chart 207, 91-00-00).
- h. Fill the pressure seals with MIL-G-23827 grease (11, Chart 207, 91-00-00). Install the seals.
- i. Rig the aileron control system.
- j. Install the access plates on the lower trailing edge of the wings.
- k. Install the floorboards and the forward passenger seats.
- l. Install the floorboards and the pilot's and copilot's seats.

### ***AILERON CONTROL SYSTEM RIGGING*** (Figure 201)

- a. The contour of the aileron must align with the contour of the wing within 1/16 inch (.0625 inch) on either or both sides.
- b. Aileron and connecting linkage may have a maximum of 1/16 inch lost motion. Check for lost motion at the midpoint of the aileron trailing edge with the bell crank stationary.
- c. The aileron is in neutral when its outboard trailing edge aligns with the trailing edge of the wing tip and its inboard end is parallel with the outboard end of the flap. A horizontal misalignment of plus or minus 3/16 inch is allowed between trailing edges of the aileron and wing tip. With the bell crank parallel to the wing rib, set the aileron in neutral by adjusting the length of the push-pull tube. Loosen the locknuts on both ends and turn the tube to shorten or lengthen.
- d. Securely tighten the locknuts on all rod ends. Rig cable tension and adjust travel as noted on Aileron Rigging Illustration.
- e. With the aileron system fully rigged, the maximum force required to move the control wheel 10 degrees to the left and right of neutral should not exceed 15 inch-pounds.

### ***AILERON TRIM TAB CABLE REMOVAL*** (Figure 201)

- a. Remove the pilot's seat and the left floorboard.
- b. Remove the lower forward upholstery panel on the

**BEECHCRAFT  
DUKE 60 SERIES  
MAINTENANCE MANUAL**

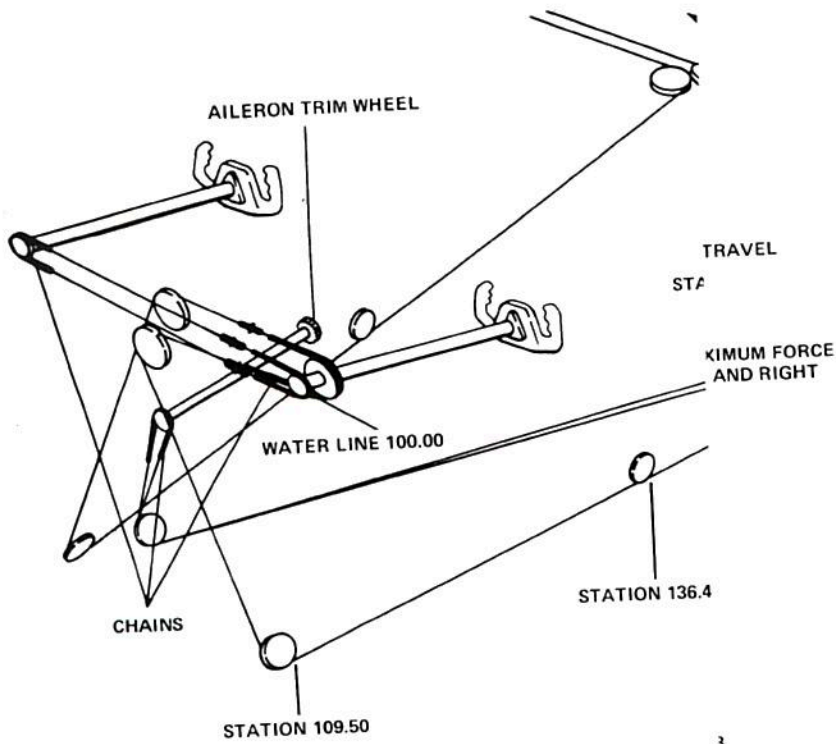

3

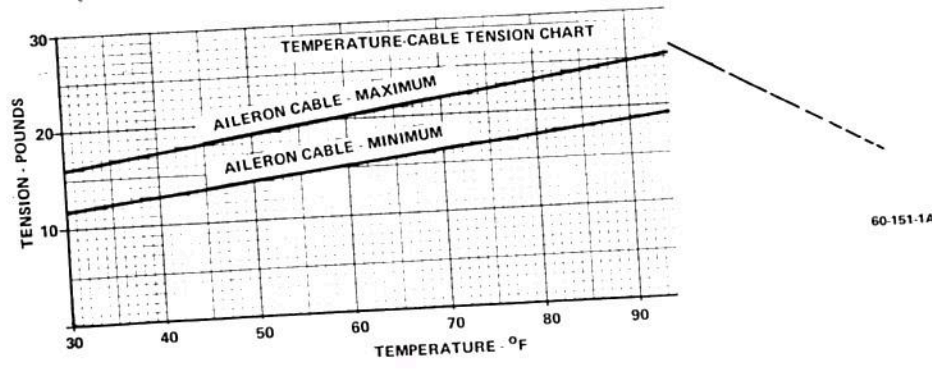
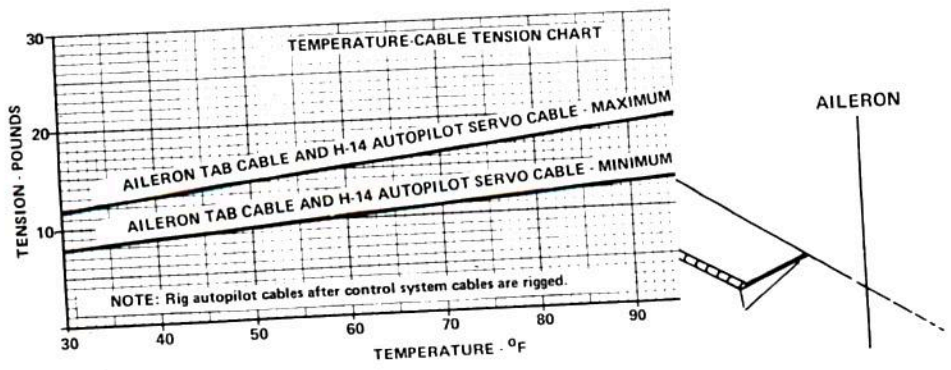

**Rigging the Aileron Control System  
Figure 201**

**BEECHCRAFT  
DUKE 60 SERIES  
MAINTENANCE MANUAL**

left side of the pedestal.

c. Remove the forward left passenger seat and the floorboard.

d. Remove the necessary access plates to gain access to the trim tab cables, the actuator, and the cable pulley brackets.

e. Remove the cable retaining pins at the pulley brackets.

f. Disconnect the tab cables at the turnbuckles in the left wing. Identify and connect lead lines on the cable ends.

g. Remove the cable stops and the pressure seals.

h. Remove the outboard cable from the actuator sprocket. Remove the cable through the actuator access opening.

i. Remove one chain link at the sprocket on the pedestal. Remove the cable through the pilot's compartment.

#### ***AILERON TRIM TAB CABLE INSTALLATION***

a. Position the chain of the forward tab cable around the pedestal sprocket and install the chain link.

b. Route the cable ends aft in the fuselage and outboard into the left wing.

c. Position the chain of the outboard cable around the actuator sprocket and route the cable ends inboard.

d. Install the cable stops and connect the cables at the turnbuckles in the wing.

e. Install all cable retaining pins in the pulley brackets.

f. Using PD680 solvent (15, Chart 207, 91-00-00), clean the cables for the length of travel through the pressure seals. Lubricate to one inch beyond the cleaned area with MIL-G-23827 grease (11, Chart 207, 91-00-00).

g. Fill the pressure seals with MIL-G-23827 grease (11, Chart 207, 91-00-00). Install the seals.

h. Rig the aileron trim tab control system.

i. Install all access plates in the left wing.

j. Install the floorboard and the left forward passenger seat.

k. Install the floorboard and the pilot's seat.

l. Install the upholstery panel on the left side of the pedestal.

#### ***AILERON TRIM TAB RIGGING (Figure 201)***

a. Place cockpit aileron trim tab control in neutral position.

b. Place aileron in neutral position and connect trim tab to tab actuator.

c. By turning the sprocket on the actuator, adjust the trim tab to both extremes of travel; measure both settings and return the tab to the mid-point of the two extremes of

travel. This will place the actuator in the neutral position.

d. If the trim tab is not in the neutral position upon completion of step "c", adjust push rod to place tab in neutral position.

e. Center the chain on the sprocket and tighten the cable. Rig cable tension and adjust travel as noted on the Aileron Tab Rigging Illustration (Figure 201).

f. Check trim tab travel, adjust cable stops and safety turnbuckles.

#### **NOTE**

After rigging the aileron and aileron tab control system, check for correct movement of the control surfaces with respect to the movement of the controls.

Since the aileron tab is an anti-servo tab, every time the aileron moves up the tab should move up.

#### ***AILERON TRIM TAB ACTUATOR REMOVAL***

a. Remove the access plates at the actuator and tab cable turnbuckles.

b. Disconnect the outboard cable at the turnbuckles in the wing.

c. Remove the outboard cable from the actuator sprocket.

d. Disconnect the actuator from the trim tab linkage.

e. Remove the bolts attaching the actuator to the wing structure. Remove the actuator.

#### ***AILERON TRIM TAB ACTUATOR INSTALLATION***

a. Position the actuator against the wing structure and install the attaching bolts.

b. Connect the actuator to the tab linkage.

c. Install the outboard cable on the actuator sprocket.

d. Connect the cables at the turnbuckles in the wing.

e. Rig the aileron trim tab control system.

f. Install the access plates at the actuator and the tab cable turnbuckles.

#### ***CHECKING AILERON TAB FREE PLAY***

Visually inspect the left aileron tab for damage, security of hinge attach points, and for tightness of the actuating system. Inconsistencies should be corrected prior to checking the free play of the tab. The aileron tab free play check should be performed at least once a year to ensure that the trim tab free play falls within the prescribed limits.

**BEECHCRAFT  
DUKE 60 SERIES  
MAINTENANCE MANUAL**

A check fixture (P/N 45-135030-9/810) or the equivalent as shown in Figure 202, a dial indicator, and a push-pull scale for applying accurate loading to the tab is required for making the inspection for free play of the tab.

a. Securely lock the control surfaces to prevent movement of the ailerons. Set the aileron tab in the neutral position.

b. Using shot bags, affix the dial indicator check fixture so that the dial indicator point is 2.30 inches aft of the tab hinge line and on the outboard edge of the aileron tab.

c. Apply a small piece of masking tape (for paint protection) 4.00 inches aft of the tab hinge line and along the centerline of the tab actuator. This will be the point of pressure against the tab by the push-pull scale.

d. Apply another piece of masking tape in the corresponding position on the bottom surface of the tab for the same purpose.

e. Zero the dial indicator at no load initially. Do not reset during the checking procedure.

f. With the push-pull scale at the point of masking tape, apply a full 3-pound downward load. Record the dial reading as "A".

g. Release half the load until a 1.5-pound downward load is obtained. Record the dial reading as "B".

h. Apply a full 3-pound upward load at the masking tape on the bottom surface. Record the dial reading as "C".

i. Release half the load until a 1.5-pound upward load is obtained. Record the dial reading as "D".

j. Enter the recorded values on a copy of Chart 201 and proceed as follows:

1. Multiply "B" by 2 and record as "2B".
2. Subtract "A" from "2B" and record as "X".

3. Multiply "D" by 2 and record as "2D".

4. Subtract "C" from "2D" and record as "Y".

**NOTE**

The results of "X" and "Y" can be negative numbers.

5. Add "X" and "Y" and record as "E".

**CHART 201  
AILERON TAB FREE PLAY LIMITS**

<i>1.5-POUND READING</i>	<i>3-POUND READING</i>	
B _____		
2B _____	- A _____	= X _____
D _____		
2D _____	- C _____	= Y _____
X _____	+ Y _____	= E _____

(E = 0.032 inch maximum)

k. If the aileron trim tab free play exceeds the 0.032 inch maximum noted above, inspect all components of the tab actuation system to determine the cause. All worn parts should be replaced.



**BEECHCRAFT  
DUKE 60 SERIES  
MAINTENANCE MANUAL**

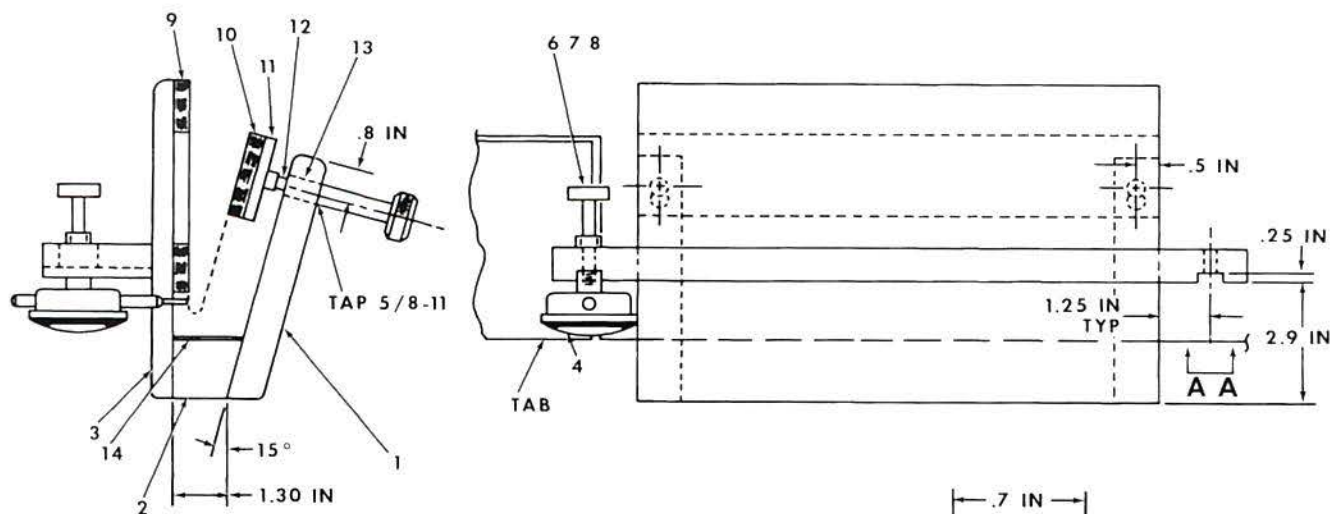

ITEM NO.	QUANT.	DESCRIPTION
1	2	3/4 x 1 x 6 aluminum or equiv.
2	2	1 x 1 3/8 x 1 3/4 aluminum or equiv.
3	1	1/2 x 7 1/2 x 10 aluminum or equiv.
4	1	C81Q Indicator**
5	1	3/4 x 2 1/2 x 14 aluminum or equiv.
6	1	1/4 Dia. x 2 corrosion res. stl.
7	1	1/4 Dia. x 1 corrosion res. stl.
8	1	1/4-28 nut
9	1	3/8 x 5 x 10 rubber
10	1	3/8 x 2 x 10 rubber
11	1	1/4 x 2 x 10 corrosion res. stl.
12	2	1/2 x 13 x 3 VLIER Torque screw
13	2	KN813 Keensert or tap 1/2 - 13
14	2	1/8 x 1 x 3/4 rubber

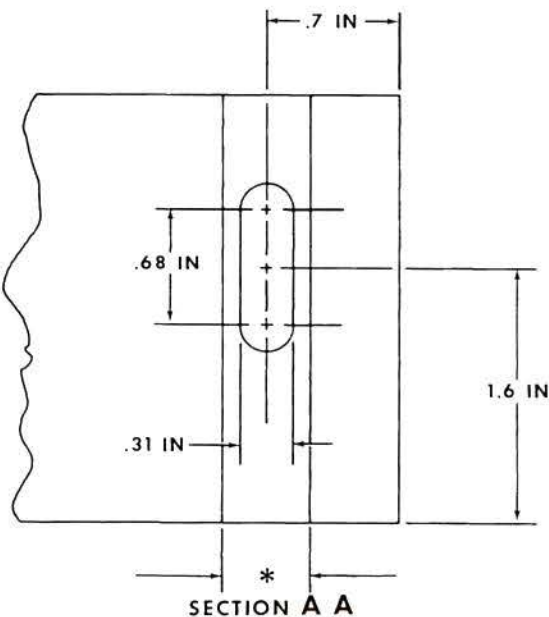

\*\*P/N of Federal Products Corp., Providence, R.I.

\* THIS GROOVE TO BE A SNUG FIT TO THE SCREW BRACKET ON THE DIAL INDICATOR

100-135-8

**(P/N 45-135030-9/810) Check Fixture for Tab Deflection  
Figure 202**

"END"



**BEECHCRAFT  
DUKE 60 SERIES  
MAINTENANCE MANUAL**

## **RUDDER AND TAB - MAINTENANCE PRACTICES**

### *RUDDER REMOVAL*

- a. Remove the tail cone and the access plate on the side of the fuselage beneath the RH horizontal stabilizer.
- b. Detach the tail cone, disconnect the tail navigation light wire, and remove the tail cone.
- c. Disconnect the rudder tab cables at the turnbuckles. Remove the tab cable retainer pins and fairlead.
- d. Remove the four bolts securing the rudder torque tube and tab pulley bracket to the rudder bell crank.
- e. Remove the upper and lower hinge bolts and remove the rudder.

### *RUDDER INSTALLATION*

- a. Align the holes in the rudder and stabilizer hinges and install the attaching bolts.
- b. Secure the tab pulley bracket and rudder torque tube to the rudder bell crank with the four attaching bolts. Torque the bolts to 50-70 inch-pounds.
- c. Connect the rudder tab cables at the turnbuckles and install the cable retainer pins and fairlead.
- d. Check the travel of the tab and the rudder tab indicator to ensure that the tab and indicator agree.
- e. Connect the tail light wires and install the tail cone. Reinstall the access plate beneath the RH horizontal stabilizer.

### *RUDDER CABLE REMOVAL*

(Figure 201)

- a. Remove the tail cone and the access plate on the side of the fuselage beneath the RH horizontal stabilizer.
- b. Remove the pilot's and copilot's seat and the floorboards in the pilot's compartment.
- c. Remove the forward passenger seats and the floorboards between the main and rear spar.
- d. Remove the access panel in the floorboard aft of the rear spar.
- e. Remove the cable retaining pins from the pulley brackets and the pressure seals from the rear pressure bulkhead.
- f. Disconnect the rudder cables, in the aft fuselage, at the turnbuckles and connect lead lines to the forward cables.
- g. Disconnect the forward cables at the bell crank and remove the cables through the pilot's compartment.
- h. Disconnect the aft cables at the rudder bell crank and remove the cables.

### *RUDDER CABLE INSTALLATION*

- a. Route the aft rudder cables forward in the tail section and connect to the rudder bell crank.

- b. Route the forward rudder cables aft from the pilot's compartment and connect the cables to the bell crank.

- c. Install all cable retaining pins in the pulley brackets.

- d. Using PD680 solvent (15, Chart 207, 91-00-00), clean the cables for the length of travel through the pressure seals. Lubricate to one inch beyond the cleaned area with MIL-G-23827 grease (11, Chart 207, 91-00-00).

- e. Fill the pressure seals with MIL-G-23827 grease (11, Chart 207, 91-00-00). Install the seals.

- f. Connect the cables to the turnbuckles in the aft fuselage and rig the cable system.

- g. Install the aft floorboard access panel, the floorboards between the main and aft spar, and the forward seats.

- h. Install the floorboards in the pilot's compartment, and the pilot's and copilot's seat.

- i. Install the tail cone and the access plate beneath the RH horizontal stabilizer.

### *RUDDER CONTROL SYSTEM RIGGING*

(Figure 201)

- a. Remove the tail cone, the access plate on the side of the fuselage beneath the RH horizontal stabilizer, and the access panel in the aft floorboard.

- b. Release the rudder pedal adjusting levers and place all pedals in the aft position.

- c. Insert a 7/16-inch diameter rig pin through the upper arm of the pilot's rudder pedals to rig neutral on the rudder pedals. This will also bring the copilot's rudder pedals to the same adjustment as the pilot's pedals.

- d. Place the rudder and rudder bell crank in the neutral position.

- e. Rig the rudder cables to the proper tension as determined by reference to the Temperature-Cable Tension Chart. Safety wire the turnbuckles.

- f. Remove the rig pin from the rudder pedals and adjust the stops for the rudder bell crank until the rudder has a travel of 33 to 35 degrees right and 28 to 30 degrees left from the centerline of the horizontal stabilizer in response to the corresponding movement of the rudder pedals.

#### **NOTE**

With the rudder and steering system fully installed, properly rigged, and the nose wheel extended and off the ground, the force required for full right rudder deflection should not exceed 25 pounds as measured at the pivot point of each rudder pedal. The force required for full left rudder deflection, measured at the rudder pedal pivot point, should not exceed 23 pounds.

- g. Install the tail cone, the access plate beneath the

**BEECHCRAFT  
DUKE 60 SERIES  
MAINTENANCE MANUAL**

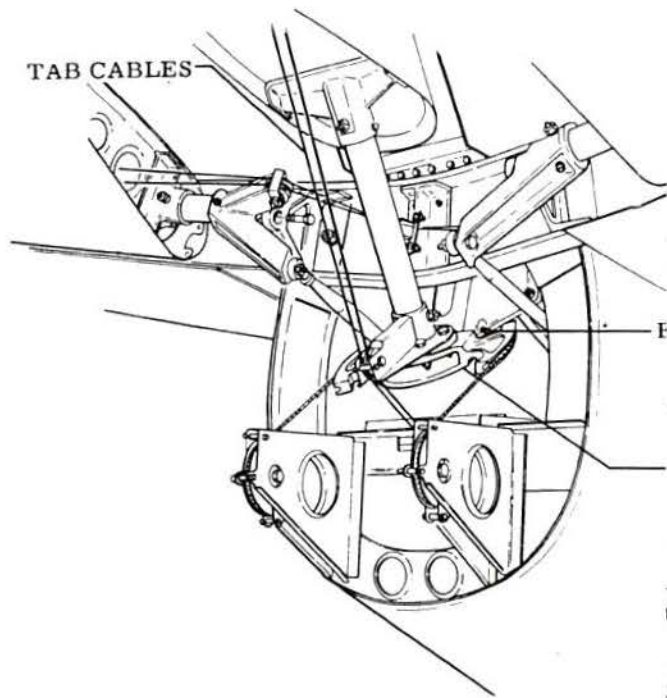

**RUDDER TAB TRAVEL**  
 19° TO 21° RIGHT  
 19° TO 21° LEFT

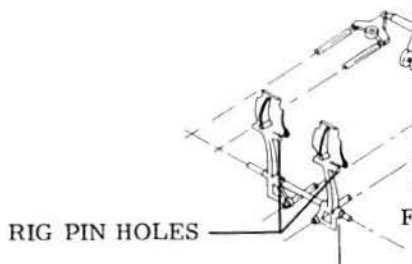
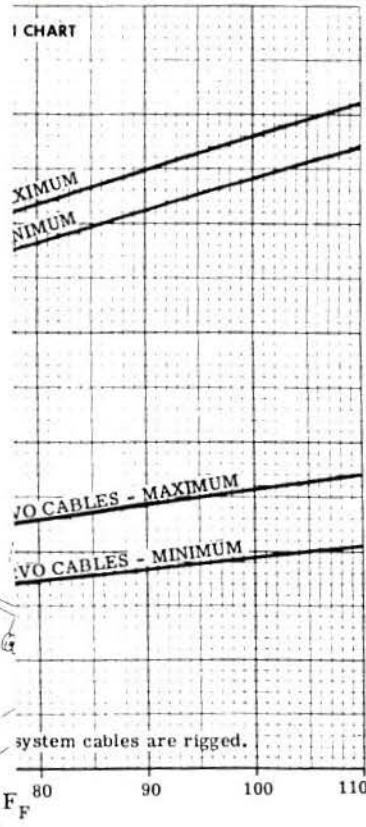

F. S. 109

60-153-1A

**Rigging the Rudder Control System  
Figure 201**

**BEECHCRAFT  
DUKE 60 SERIES  
MAINTENANCE MANUAL**

RH horizontal stabilizer, and the access panel in the aft floorboard.

#### ***RUDDER TRIM TAB CABLE REMOVAL***

(Figure 201)

- a. Remove the tail cone, the access plate beneath the RH horizontal stabilizer, and the access plate at the trim tab actuator.
- b. Remove the pilot's seat and the left floorboard.
- c. Remove both upholstery panels on the left side of the pedestal.
- d. Remove the left passenger seat, the floorboard between the main and rear spar, and the access panel in the floorboard aft of the rear spar.
- e. Remove the cable retaining pins from the pulley brackets and the pressure seals from the rear pressure bulkhead.
- f. Disconnect the trim tab cables, in the aft fuselage, at the turnbuckles and connect lead lines to the forward cables. Identify the lead line for tab left and tab right movement to ensure proper cable rerouting.
- g. Remove the taper pin from the forward universal and remove the attaching shaft and cable reel. Note and record the number of cable revolutions on the reel.
- h. Remove the forward trim tab cable through the pilot's compartment.
- i. Remove the tab cable stops and disconnect the chain and cable assembly at the trim tab actuator. Remove the aft cable chain and cable assembly.

#### ***RUDDER TRIM TAB CABLE INSTALLATION***

(Figure 201)

- a. With the rudder tab in neutral, position the aft chain and cable assembly on the trim tab actuator sprocket so that the ends of the chain are equi-distant at the sprocket centerline within  $\pm .20$  inch.
- b. Route the aft chain and cable assembly forward in the aft fuselage.
- c. Place the rudder trim tab control wheel in neutral position and wrap the forward cable around the reel the same number of revolutions noted during removal, maintaining the cable ends equi-distant.
- d. Install the attaching shaft, washer and reel; align the shaft with the forward universal and install the taper pin.

#### **NOTE**

When the trim tab control cable is disconnected at the pedestal, the tab wheel shall turn smoothly with very little resistance. Bearings not previously lubricated may be lubricated with MIL-L-6086 lubricating oil (7, Chart 207, 91-00-00). Lubricate shafts and thrust surfaces in all trim tab systems with MIL-G-23827 grease (11, Chart 207, 91-00-00) for friction reduction.

- e. Route the forward cable end aft and install all cable retaining pins in the pulley brackets.
- f. Using PD680 solvent (15, Chart 207, 91-00-00), clean the cables for the length of travel through the pressure seals. Lubricate to one inch beyond the cleaned area with MIL-G-23827 grease (11, chart 207, 91-00-00).
- g. Fill the pressure seals with MIL-G-23827 grease (11, Chart 207, 91-00-00). Install the seals.
- h. Install the cable stops and connect the cables to the turnbuckles in the aft fuselage. Rig the rudder trim tab control system.
- i. Install the access panel in the floorboard aft of the rear spar, the floorboard between the main and rear spar, and the left passenger seat.
- j. Install both upholstery panels on the left side of the pedestal.
- k. Install the left floorboard and the pilot's seat.
- l. Install the tail cone, the access plate beneath the RH horizontal stabilizer and the access plate at the trim tab actuator.

#### ***RUDDER TRIM TAB RIGGING***

- a. Disconnect the tab from its actuator.
- b. Position the rudder in neutral and set the tab indicator at zero degrees.
- c. Rig the tab cables to the proper tension as determined by the Temperature-Cable Tension Chart. Safety wire the turnbuckles.
- d. Position the tab actuator screw at the midpoint of its travel.
- e. Adjust the actuator linkage until the tab is in the neutral position with the chain centered on the actuator sprocket and connect the tab to the actuator.
- f. Adjust the cable stops until the rudder tab has a travel of 19 to 21 degrees to both the left and right.
- g. Torque the cable stops to 40 to 60 inch-pounds and safety.
- h. Check the tab control and tab surface for correct movement as indicated by the tab indicator. When the tab control is moved to the left, the tab should move to the right.
- i. Check the rudder trim tab control system for friction at the tab control wheel shaft. At room temperature, the maximum allowable torque limit is 12 inch-pounds.

#### ***RUDDER TRIM TAB ACTUATOR REMOVAL***

- a. Remove the access plate at the trim tab actuator.
- b. Remove the tail cone and the access plate beneath the RH horizontal stabilizer.
- c. Remove the access panel in the floorboard aft of the rear spar.
- d. Disconnect the tab control cables at the turnbuckles in the aft fuselage.
- e. Disconnect the tab actuator at the tab.
- f. Remove the aft chain and cable assembly from the actuator sprocket.

**BEECHCRAFT  
DUKE 60 SERIES  
MAINTENANCE MANUAL**

g. Remove the bolt attaching the actuator to the actuator hinge. Remove the actuator.

**RUDDER TRIM TAB ACTUATOR INSTALLATION**

- a. Position the tab actuator on the actuator hinge and install the attaching bolt.
- b. Connect the actuator at the tab.
- c. With the rudder tab in neutral, position the aft chain and cable assembly on the actuator sprocket so that the ends of the chain are equi-distant at the sprocket centerline within  $\pm .20$  inch.
- d. Connect the tab control cables to the turnbuckles in the aft fuselage.
- e. Rig the rudder tab control system.
- f. Install the access panel in the floor board aft of the rear spar.
- g. Install the tail cone and the access plate beneath the RH horizontal stabilizer.
- h. Install the access plate at the trim tab actuator.

**CHECKING RUDDER TAB FREE PLAY**

Visually inspect the rudder tab for damage, security of hinge attach points, and for tightness of the actuating system. Inconsistencies should be corrected prior to checking the free play of the tab. The rudder tab free play check should be performed at least once a year to ensure that the trim tab free play falls within the prescribed limits.

A check fixture (P/N 45-135030-9/810) or the equivalent as shown in Figure 202, a dial indicator, and a push-pull scale for applying accurate loading to the tab is required for making the inspection for free play of the tab.

- a. Securely lock the control surface to prevent movement of the rudder. Set the rudder tab in the neutral position.
- b. Tape the dial indicator check fixture to the rudder so that the dial indicator point is positioned 8.70 inches aft of the tab hinge line and at the top edge of the tab.
- c. Apply a small piece of masking tape (for paint protection) 9.0 inches aft of the tab hinge line and along the centerline of the tab actuator. This will be the point of pressure against the tab by the push-pull scale.
- d. Apply another piece of masking tape in the corresponding position on the opposite side for the same purpose.
- e. Zero the dial indicator at no load initially. Do not reset during the checking procedure.

f. With the push-pull scale at the point of masking tape, apply a full 3-pound load to the right. Record the dial reading as "A".

g. Release half the load until a 1.5-pound load is obtained. Record the dial reading as "B".

h. Apply a full 3-pound load at the masking tape on the opposite surface. Record the dial reading as "C".

i. Release half the load until a 1.5-pound load is obtained. Record the dial reading as "D".

j. Enter the recorded values on a copy of Chart 201 and proceed as follows:

1. Multiply "B" by 2 and record as "2B".
2. Subtract "A" from "2B" and record as "X".
3. Multiply "D" by 2 and record as "2D".
4. Subtract "C" from "2D" and record as "Y".

**NOTE**

The results of "X" and "Y" can be negative numbers.

5. Add "X" and "Y" and record as "E".

**CHART 201  
RUDDER TAB FREE PLAY LIMITS**

1.5 POUND READING	3-POUND READING	
B _____		
2B _____	- A _____	= X _____
D _____		
2D _____	- C _____	= Y _____
X _____	+ Y _____	= E _____

(E = 0.061 inch maximum)

k. If the rudder trim tab free play exceeds the 0.061 inch maximum noted above, inspect all components of the tab actuation system to determine the cause. All worn parts should be replaced.

BEECHCRAFT  
DUKE 60 SERIES  
MAINTENANCE MANUAL

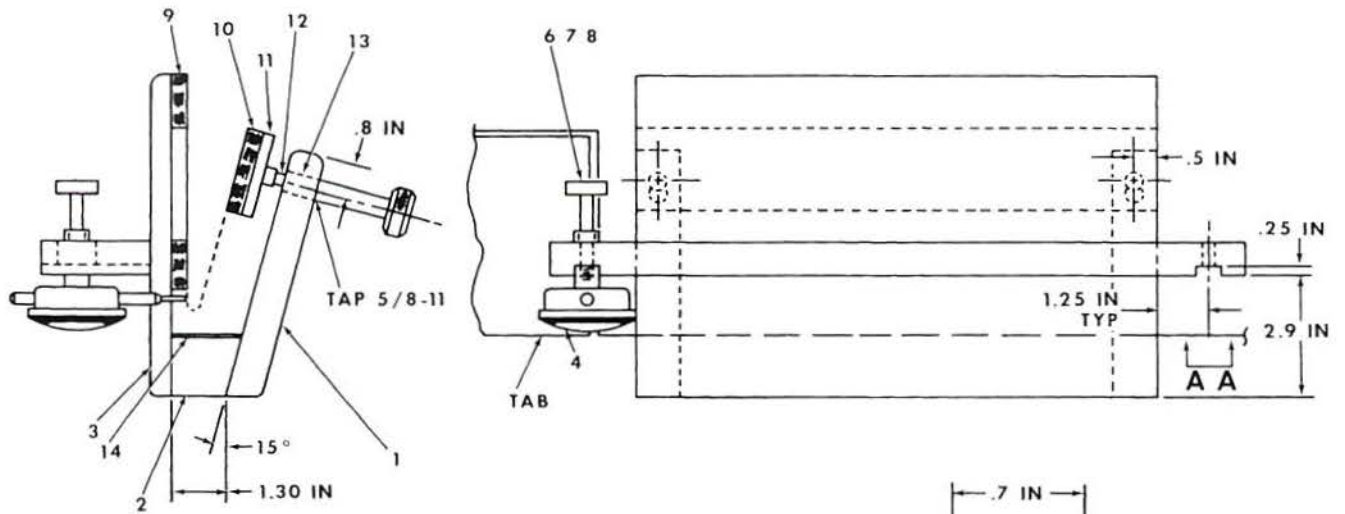

ITEM NO.	QUANT.	DESCRIPTION
1	2	3/4 x 1 x 6 aluminum or equiv.
2	2	1 x 1 3/8 x 1 3/4 aluminum or equiv.
3	1	1/2 x 7 1/2 x 10 aluminum or equiv.
4	1	C81Q Indicator**
5	1	3/4 x 2 1/2 x 14 aluminum or equiv.
6	1	1/4 Dia. x 2 corrosion res. stl.
7	1	1/4 Dia. x 1 corrosion res. stl.
8	1	1/4-28 nut
9	1	3/8 x 5 x 10 rubber
10	1	3/8 x 2 x 10 rubber
11	1	1/4 x 2 x 10 corrosion res. stl.
12	2	1/2 x 13 x 3 VLIER Torque screw
13	2	KN813 Keensert or tap 1/2 - 13
14	2	1/8 x 1 x 3/4 rubber

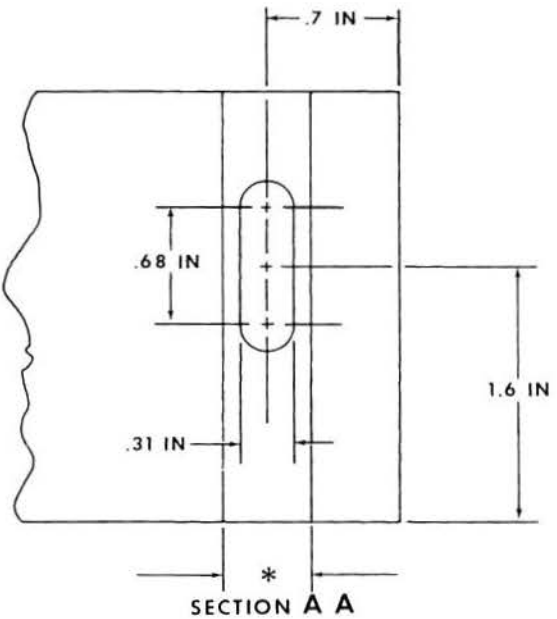

\* THIS GROOVE TO BE A SNUG FIT  
TO THE SCREW BRACKET ON  
THE DIAL INDICATOR

\*\*P/N of Federal Products Corp., Providence, R.I.

100-135-8

(P/N 45-135030-9/810) Check Fixture for Tab Deflection  
Figure 202

"END"





**BEECHCRAFT  
DUKE 60 SERIES  
MAINTENANCE MANUAL**

## **ELEVATOR AND TAB - MAINTENANCE PRACTICES**

### *ELEVATOR REMOVAL*

- a. Remove the tail cone and the access plate on the side of the fuselage beneath the RH horizontal stabilizer.
- b. Loosen the elevator trim tab cables.
- c. Disconnect the trim tab cables from the trim tab actuator chain by removing the master link at each end of the chain.
- d. Disconnect the elevator push rods from the elevator torque tube fittings.
- e. Remove the bolt from the inboard end of the elevator torque tube.
- f. Remove the hinge bolts. Disconnect the elevator bonding cables and remove the elevator.

### *ELEVATOR INSTALLATION*

- a. Connect the elevator bonding cables. Position the elevator on the stabilizer and install the hinge bolts, washers and nuts. Tighten and safety.
- b. Install the bolt in the inboard end of the elevator torque tubes. Torque the attaching bolts to 50-70 inch pounds.
- c. Attach the elevator push rods to the elevator torque tube fittings. Torque the attaching bolts to 20-25 inch-pounds.
- d. Position the elevator trim tab cables on the ends of the trim tab actuator chain and install the master links.
- e. Adjust the tension on the elevator trim tab cables as noted on the Elevator Rigging Illustration, Figure 201.

#### **NOTE**

Check the trim tab system for correct movement of the control surface with respect to the movement of the trim tab control. When the elevator tab control is moved toward the NOSE DOWN position, the tab should move UP.

- f. Connect the tail light wires and install the tail cone. Install the access plate on the side of the fuselage beneath the RH horizontal stabilizer.

### *ELEVATOR CABLE REMOVAL*

(Figure 201)

- a. Remove the tail cone and the access plate on the side of the fuselage beneath the RH horizontal stabilizer.
- b. Remove the pilot's and copilot's seat and the floorboards in the pilot's compartment.

- c. Remove the forward passenger seats and the floorboards between main and rear spar.
- d. Remove the access panel in the floorboard aft of the rear spar.
- e. Remove the cable retaining pins from the pulley brackets and the pressure seals from the rear pressure bulkhead.
- f. Disconnect the elevator cables, in the aft fuselage, at the turnbuckles and connect lead lines to the forward cables.
- g. Disconnect the cables at the forward bell crank. Identify both forward cables in relation to their attaching point on the bell crank. Remove the cables.
- h. Disconnect the cables at the aft bell crank. Identify both aft cables in relation to their attaching point on the bell crank arms. Remove the cables.

### *ELEVATOR CABLE INSTALLATION*

(Figure 201)

- a. Route the aft elevator cables forward and connect to the applicable bell crank arms as noted during cable removal.
- b. Route the forward elevator cables aft and connect to the bell crank as noted during cable removal.
- c. Install all cable retaining pins in all pulley brackets.
- d. Using PD680 solvent (15, Chart 207, 91-00-00), clean the cables for the length of travel through the pressure seals. Lubricate to one inch beyond the cleaned area with MIL-G-23827 grease (11, Chart 207, 91-00-00).
- e. Fill the pressure seals with MIL-G-23827 grease (11, Chart 207, 91-00-00). Install the seals.
- f. Connect the cables to the turnbuckles in the aft fuselage and rig the cable system.
- g. Install the aft floorboard access panel, the floorboards between the main and aft spar, and the forward seats.
- h. Install the floorboards in the pilot's compartment, and the pilot's and copilot's seats.
- i. Install the tail cone and the access plate beneath the RH horizontal stabilizer.

### *ELEVATOR CONTROL SYSTEM RIGGING*

(Figure 201)

#### **WARNING**

When replacing or installing control cables, bell cranks and other control system components, observe the color coding on all parts. DO NOT connect coded parts of one color to coded parts of a different color.

#### **NOTE**

BEECHCRAFT recommends the use of the elevator travel gage shown in SPECIAL TOOLS in Chapter 12-20-00.

**BEECHCRAFT  
DUKE 60 SERIES  
MAINTENANCE MANUAL**

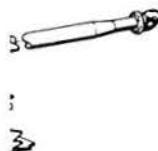
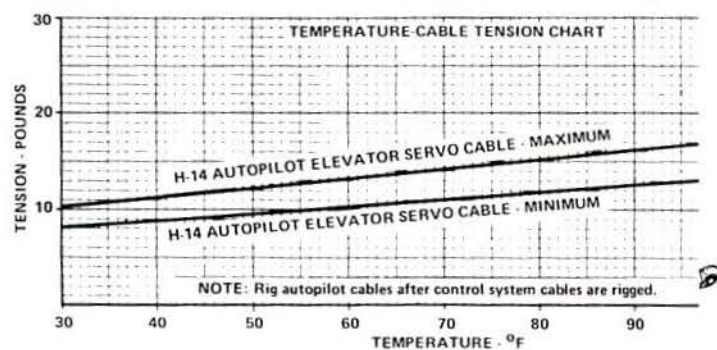
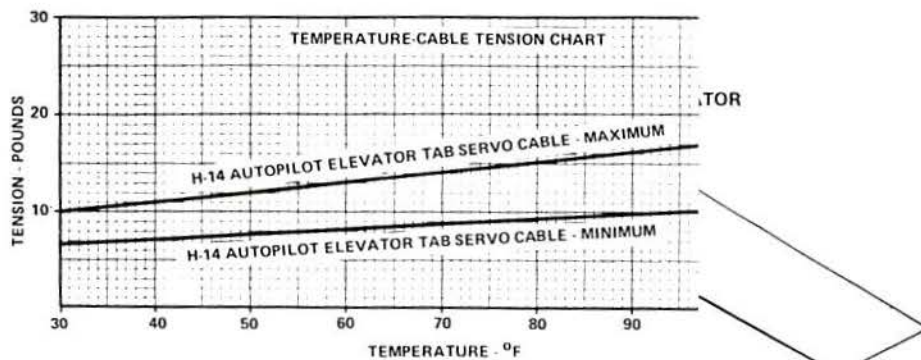

R STOP BOLTS

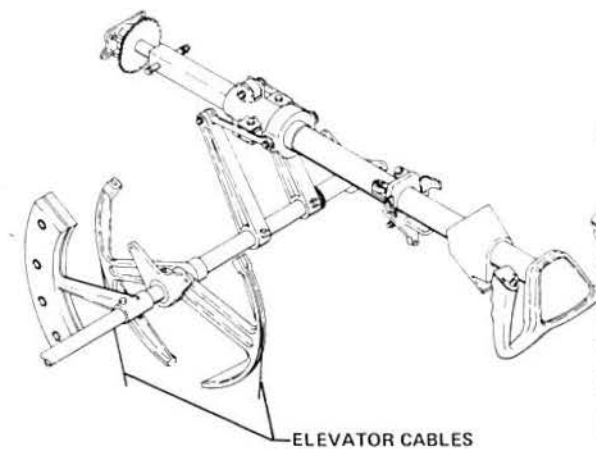

DETAIL A

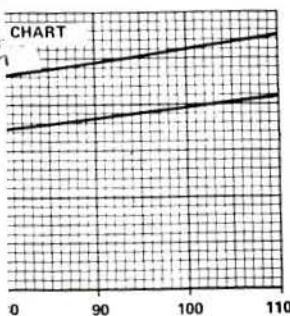

60-152-1A

Rigging the Elevator Control System  
Figure 201

**BEECHCRAFT  
DUKE 60 SERIES  
MAINTENANCE MANUAL**

**NOTE**

To position the elevator in neutral on airplane serials P-438 and after, fabricate a tool from 5/16 inch diameter steel rod as shown in Figure 201A.

- a. Remove the tail cone and the access plate on the side of the fuselage beneath the RH horizontal stabilizer.
- b. Position the aft elevator bell crank in neutral by inserting a 3/16 inch diameter rig pin through the bell crank and adjacent structure.
- c. Adjust the elevator push rods to place the elevator in neutral.

**NOTE**

After the push rods are adjusted, the threads on the rod ends must be visible in the inspection holes at each end of the push rods.

- d. Remove the rig pin from the aft elevator bell crank and adjust the elevator travel stops to obtain  $17^\circ \pm 1^\circ$  up travel and  $15^\circ \pm 1^\circ$  down travel.

FABRICATE FROM 5/16-INCH DIAMETER STEEL ROD

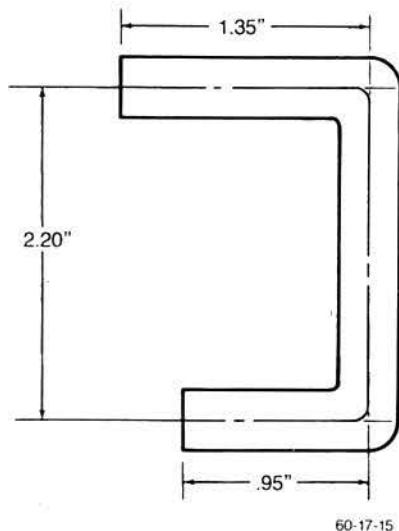

**Elevator Neutral Rigging Tool  
(P-438 and after)  
Figure 201A**

- e. On airplane serials prior to P-438, insert a 1/4 inch diameter rig pin in the control lock pin hole in the control column. Insert a 3/16 inch diameter rig pin in the aft elevator bell crank and adjacent structure.

f. To set the elevator controls in neutral on airplane serials P-438 and after, insert the short end of the fabricated tool (see Figure 201A) in the control column hanger. Move the control aft and insert the other end of the tool into the control shaft and torque tube. Insert a 3/16 inch diameter rig pin in the aft elevator bell crank and adjacent structure.

g. With the rig pins and elevator down springs installed, rig the elevator cable tension as noted on the Elevator Rigging Illustration, Figure 201.

h. Remove the rig pins, securely tighten all lock nuts and safety wire the turnbuckles.

**NOTE**

With the system fully installed (including the autopilot when installed) measure the force required to move the control column from the full forward position through neutral with a hand force gage. This force should measure between 32 and 36 pounds. The force required to restrain the control column when passing through neutral from a position not more than one inch aft of neutral should measure between 16 and 20 pounds when the system is properly rigged.

**NOTE**

After rigging the elevator and elevator tab control system, check for correct movement of the control surfaces with respect to the movement of the controls. When the elevator trim tab control wheel is moved toward the NOSE DOWN position, the elevator tab should move UP.

- i. Install the tail cone and the access plate on the side of the fuselage beneath the RH horizontal stabilizer.

**ELEVATOR TRIM TAB CABLE REMOVAL  
(Figure 201)**

- a. Remove the tail cone, the access plate beneath the RH horizontal stabilizer, and the access plate at the trim tab actuator.
- b. Remove the pilot's seat and the left floorboard.
- c. Remove both upholstery panels on the left side of the pedestal.

**BEECHCRAFT  
DUKE 60 SERIES  
MAINTENANCE MANUAL**

d. Remove the left passenger seat, the floorboard between the main and rear spar, and the access panel in the floorboard aft of the rear spar.

e. Remove the cable retaining pins from the pulley brackets and the pressure seals from the rear pressure bulkhead.

f. Disconnect the trim tab cables, in the aft fuselage, at the turnbuckles. Identify the cable for tab up movement and connect lead lines to the cables.

g. Remove the pressure seals in the rear pressure bulkhead.

h. Remove the tab cable stops and disconnect the chain and cable assembly at the trim tab actuator. Remove the aft cable and chain assembly.

i. Remove the bolt attaching the cable drum and sprocket to the lower pedestal. Note and record the number of cable revolutions on the reel.

j. Remove the cable through the pilot's compartment.

***ELEVATOR TRIM TAB CABLE INSTALLATION  
(Figure 201)***

a. Place the elevator trim tab control wheel in neutral position and wrap the cable around the drum the same number of revolutions noted during removal, maintaining the cable ends equidistant.

b. Position the cable drum and sprocket in the lower pedestal, with the chain and sprocket teeth engaged, and install the attaching bolt. Route the forward cable aft to the LH trim cable pulley located in the lower fuselage area. Route the aft cable aft to the RH trim cable pulley located in the lower fuselage area.

**NOTE**

When the trim tab control cable is disconnected at the pedestal, the tab wheel shall turn smoothly with very little resistance. Bearings not previously lubricated may be lubricated with MIL-L-6086 oil (7, Chart 207, 91-00-00). Lubricate shafts and thrust surfaces with MIL-G-23827 grease (11, Chart 207, 91-00-00) for friction reduction.

c. With the elevator tab in neutral, position the aft cable and chain assembly on the trim tab actuator sprocket so that the ends of the chain are equidistant at the sprocket centerline within  $\pm .20$  inch.

d. Route the chain and cable assembly inboard and forward in the aft fuselage.

e. Install all cable retaining pins in the pulley brackets.

f. Using PD680 solvent (15, Chart 207, 91-00-00), clean the cables for the length of travel through the pressure seals. Lubricate to one inch beyond the cleaned area with MIL-G-23827 grease (11, Chart 207, 91-00-00).

g. Fill the pressure seals with MIL-G-23827 grease (11, Chart 207, 91-00-00). Install the seals.

h. Install the cable stops and connect the cables to the turnbuckles in the aft fuselage. Rig the elevator trim tab control system.

**NOTE**

The force in line with the elevator tab cables required to move the cable shall not exceed 23 pounds measured with a hand held force gage, with or without electric trim.

i. Install the access panel in the floorboard aft of the rear spar, the floorboard between the main and aft spar, and the left passenger seat.

j. Install the left floorboard and the pilot's seat.

k. Install both upholstery panels on the pedestal.

l. Install the tail cone, the access plate beneath the RH horizontal stabilizer, and the access plate at the trim tab actuator.

***ELEVATOR TRIM TAB RIGGING***

**NOTE**

BEECHCRAFT recommends the use of the elevator travel gage shown in SPECIAL TOOLS in Chapter 12-20-00.

a. Place the elevator trim tab control in neutral position.

b. Place the elevator in neutral position and connect the trim tab to the trim tab actuator.

c. By turning the sprocket on the actuator, adjust the trim tab to both extremes of travel; measure both settings and return the tab to the mid-point of the two extremes of travel. This will place the actuator in the neutral position.

d. If the trim tab is not in the neutral position upon completion of step "c.", adjust the actuator push rod to place the tab in neutral position.

e. Center the chain on the sprocket and tighten the cable. Rig cable tension as noted on the Elevator Rigging Illustration, Figure 201.

f. Check trim tab travel, adjust stops and safety turnbuckles.

**BEECHCRAFT  
DUKE 60 SERIES  
MAINTENANCE MANUAL**

**NOTE**

Check the trim tab system for correct movement of the control surface with respect to the movement of the trim tab control. When the elevator tab control is moved toward the NOSE DOWN position, the tab should move up.

***ELEVATOR TRIM TAB ACTUATOR REMOVAL***

- a. Remove the access plate at the trim tab actuator.
- b. Remove the tail cone and the access plate beneath the RH horizontal stabilizer.
- c. Remove the access panel in the floorboard aft of the rear spar.
- d. Disconnect the tab control cables at the turnbuckles in the aft fuselage.
- e. Disconnect the tab actuator at the tab.
- f. Remove the bolt attaching the actuator to the elevator. Remove the actuator, and the chain and cable assembly from the actuator sprocket.

***ELEVATOR TRIM TAB ACTUATOR INSTALLATION***

- a. Position the chain and cable assembly on the actuator sprocket so that the ends of the chain are equidistant at the sprocket centerline within  $\pm .20$  inch. Install the bolt attaching the actuator to the elevator.
- b. Connect the actuator to the tab.
- c. Connect the cables to the turnbuckles in the aft fuselage. Rig the tab control system.
- d. Install the access panel in the floorboard.
- e. Install the tail cone and the access plate beneath the RH horizontal stabilizer.
- f. Install the access plate at the trim tab actuator.

***ELECTRIC TRIM TAB ACTUATOR REMOVAL***

- a. Remove the access plate on the side of the fuselage beneath the RH horizontal stabilizer. The actuator

is located on Fuselage Station 311.19 bulkhead adjacent to the trim tab cables.

- b. Disconnect the actuator wire harness at the disconnect splices.
- c. Disconnect the actuator cable at the turnbuckle, then tape the cable to the actuator to prevent the cable from unwinding.
- d. Remove the three bolts securing the actuator to the bracket and remove the actuator from the airplane.

***ELECTRIC TRIM TAB ACTUATOR INSTALLATION***

- a. Secure the actuator to the mounting bracket with the three attaching bolts.
- b. Connect the actuator cables at the turnbuckles in the aft fuselage.
- c. Connect the actuator wire harness at the splices.
- d. Rig the tab control system.

**NOTE**

The tab rigging and cable tension are identical to the manually operated tab.

- e. Check that the elevator trim tab cable travels from stop to stop in 18 to 20 seconds with 28.5 VDC applied to the airplane electrical system. If necessary, adjust the resistor mounted adjacent to the actuator until cable travel is within the desired limit.
- f. Install the access plate beneath the RH horizontal stabilizer.

***ELECTRIC TRIM TAB CABLE INSTALLATION***

Note the position of the old cable on the cable drum in relation to the forward cable end fittings. Install the new



**BEECHCRAFT  
DUKE 60 SERIES  
MAINTENANCE MANUAL**

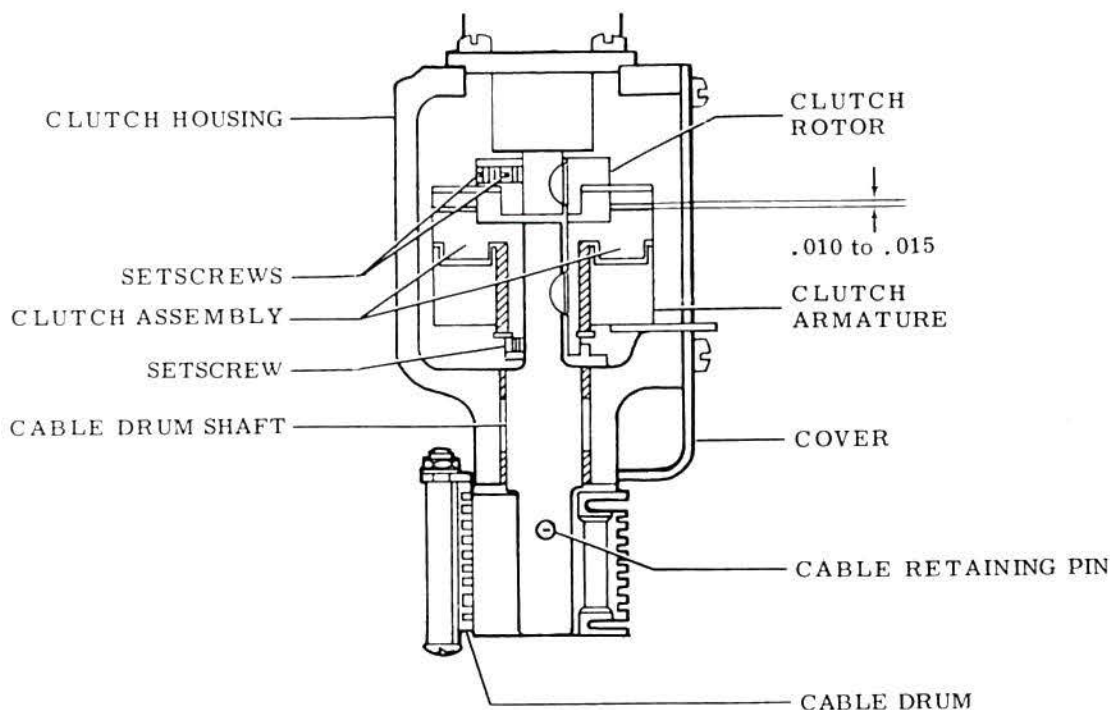

60-364-1

**Electric Trim Tab Actuator  
Figure 202**

cable in the same position. This will ensure adequate free cable on the drum in both directions to allow full travel of the cable stops. Check cable travel as instructed in step "e." of the ELECTRIC TRIM TAB ACTUATOR INSTALLATION.

***ELECTRIC TRIM TAB ACTUATOR MAGNETIC CLUTCH REMOVAL (Figure 202)***

- a. Remove the lid from the clutch housing.
- b. Loosen the set screw in the clutch rotor and armature hubs.
- c. Remove the motor from the clutch housing.
- d. Slide the cable drum and shaft assembly from the clutch housing.
- e. Remove the clutch from the clutch housing.

***ELECTRIC TRIM TAB ACTUATOR MAGNETIC CLUTCH INSTALLATION (Figure 202)***

- a. Install the clutch in the clutch housing.
- b. Slide the cable drum and shaft assembly into the clutch housing.
- c. Tighten the clutch armature set screws until there is no visible end play in the cable drum shaft. Slide the clutch rotor on the motor shaft to obtain .010 to .015 inch clearance between the friction surfaces of the clutch before

tightening the set screws. Stake both set screws.

**CAUTION**

With no visible end play in the cable drum shaft, the clutch faces must not make contact while the clutch is de-energized or damage to the clutch will result.

***ELECTRIC TRIM TAB ACTUATOR MAGNETIC CLUTCH TORQUE TEST***

The following procedure should be performed any time the magnetic clutch is replaced.

- a. Connect the red electrical lead of the magnetic clutch to ground and the white electrical lead to a 28 VDC power source. Check that the clutch holds with 30 inch-pounds of torque applied through a torque wrench at the actuator shaft.

- b. If the static torque of the clutch is less than 30 inch-pounds, burn in the clutch as follows:

1. Use a metal plate of sufficient thickness for rigidity and large enough to fit in a vise with the actuator

**BEECHCRAFT  
DUKE 60 SERIES  
MAINTENANCE MANUAL**

assembly attached. Anchor the plate in a vise and mount the actuator on the plate.

2. Insert the retaining pin in the actuator shaft.
3. Slot the end of the tube so that it will fit snugly into the .375 inch diameter hole in the end of the shaft.
4. Insert the tube into the shaft until the slot engages the retaining pins.
5. Attach the free end of the tube to a slow speed (approximately 450 rpm) half-inch drill motor.
6. Remove the access plate from the clutch housing and blow the housing and clutch clean.
7. Connect the red electrical lead of the clutch to ground and the white electrical lead to a regulated power source set at 14 to 16 VDC.
8. Start the drill motor and run for fifteen seconds, then remove the white lead from the power source. Let the clutch cool for approximately one minute before reattaching the lead for another fifteen second interval. Repeat the foregoing sequence until the clutch will hold 30 inch-pounds of torque as indicated in step "a", then blow the clutch and housing clean with compressed air.

**CAUTION**

Exceeding the fifteen second burn-in periods may overheat and damage the magnetic clutch.

**CHECKING ELEVATOR TAB FREE PLAY**

Visually inspect the elevator tabs for damage, security of hinge attach points, and for tightness of the actuating system. Inconsistencies should be corrected prior to checking the free play of the tabs. The elevator tab free play check should be performed at least once a year to ensure that the trim tab free play falls within the prescribed limits.

A check fixture (P/N 45-135030-9/810) or the equivalent as shown in Figure 203, a dial indicator, and a push-pull scale for applying accurate loading to the tab is required for making the inspection for free play of the tab.

- a. Securely lock the control surfaces to prevent movement of the elevators. Set the elevator tabs in the neutral position.
- b. Using shot bags, affix the dial indicator check fixture so that the dial indicator point is positioned 2.90 inches aft of the tab hinge line and on the outboard edge of the elevator tab.
- c. Apply a small piece of masking tape (for paint protection) 4.50 inches aft of the tab hinge line and along the centerline of the tab actuator. This will be the point of pressure against the tab by the push-pull scale.

d. Apply another piece of masking tape in the corresponding position on the bottom surface of the tab for the same purpose.

- e. Zero the dial indicator at no load initially. Do not reset during the checking procedure.
- f. With the push-pull scale at the point of the masking tape, apply a full 3-pound downward load. Record the dial reading as "A".
- g. Release half the load until a 1.5-pound downward load is obtained. Record the dial reading as "B".
- h. Apply a full 3-pound upward load at the masking tape on the bottom surface. Record the dial reading as "C".
- i. Release half the load until a 1.5-pound upward load is obtained. Record the dial reading as "D".
- j. Enter the recorded values on a copy of Chart 201 and proceed as follows:

1. Multiply "B" by 2 and record as "2B".
2. Subtract "A" from "2B" and record as "X".
3. Multiply "D" by 2 and record as "2D".
4. Subtract "C" from "2D" and record as "Y".

**NOTE**

The results of "X" and "Y" can be negative numbers.

5. Add "X" and "Y" and record as "E".

**CHART 201  
ELEVATOR TAB FREE PLAY LIMITS**

<i>1.5 POUND READING</i>	<i>3-POUND READING</i>	
B _____		
2B _____	- A _____	= X _____
D _____		
2D _____	- C _____	= Y _____
X _____	+ Y _____	= E _____

(E = 0.020 inch maximum).

k. If the elevator trim tab free play exceeds the 0.020 inch maximum noted above, inspect all components of the tab actuation system to determine the cause. All worn parts should be replaced.



**BEECHCRAFT  
DUKE 60 SERIES  
MAINTENANCE MANUAL**

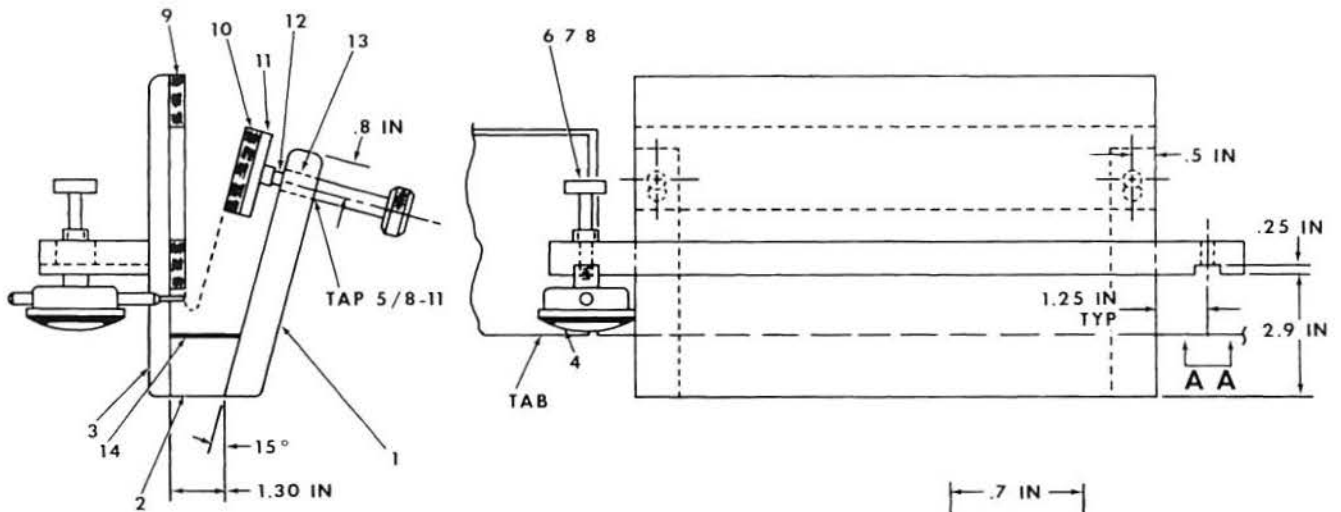

ITEM NO.	QUANT.	DESCRIPTION
1	2	3/4 x 1 x 6 aluminum or equiv.
2	2	1 x 1 3/8 x 1 3/4 aluminum or equiv.
3	1	1/2 x 7 1/2 x 10 aluminum or equiv.
4	1	C81Q Indicator**
5	1	3/4 x 2 1/2 x 14 aluminum or equiv.
6	1	1/4 Dia. x 2 corrosion res. stl.
7	1	1/4 Dia. x 1 corrosion res. stl.
8	1	1/4-28 nut
9	1	3/8 x 5 x 10 rubber
10	1	3/8 x 2 x 10 rubber
11	1	1/4 x 2 x 10 corrosion res. stl.
12	2	1/2 x 13 x 3 VLIER Torque screw
13	2	KN813 Keensert or tap 1/2 - 13
14	2	1/8 x 1 x 3/4 rubber

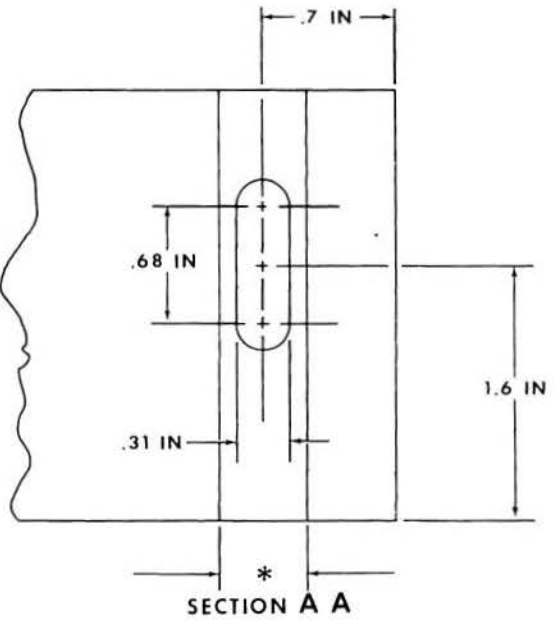

\*\*P/N of Federal Products Corp., Providence, R.I.

\* THIS GROOVE TO BE A SNUG FIT TO THE SCREW BRACKET ON THE DIAL INDICATOR

100-135-8

**(P/N 45-135030-9/810) Check Fixture for Tab Deflection  
Figure 203**

"END"



**BEECHCRAFT  
DUKE 60 SERIES  
MAINTENANCE MANUAL**

**FLAPS - DESCRIPTION AND OPERATION**

The flaps consist of a section on each wing driven by a single electric motor. A flexible drive shaft extends from the motor assembly to a jackscrew actuator for each section. Limit switches, installed on the outboard side of the inboard flap track of the left wing panel, stop the flap travel at 0° (full up), 15° (approach), and 30° (full down) depending on the position of the flap control switch located to the right of the control console on the subpanel.

To indicate the position of the flaps on serials P-4 through P-246, an adjustable flap position transmitter is installed on the flap actuator in the right wing. An indicator on the right subpanel provides a visual indication of the flap

position.

On serials P-247 and after, the position of the flaps are indicated by three indicator lights located on the right subpanel. The illumination of these lights are controlled by the flap limit switches. When the flaps are UP, all lights are out. A red TRANSIT light illuminates to indicate that the flaps are not in the selected position. The red TRANSIT light goes out and either the blue APH (approach) or the amber DN (down) light illuminates to indicate the flaps are in the position selected. The intensity of illumination is reduced for night operations when the NAV lights are turned on. The lights may be checked by pressing the PRESS-TO-TEST switch on the annunciator panel.

"END"



**BEECHCRAFT  
DUKE 60 SERIES  
MAINTENANCE MANUAL**

**FLAPS - MAINTENANCE PRACTICES**

**NOTE**

*FLAP REMOVAL*

- a. Fully extend the flaps and remove the bolt from the flap actuating arm.
- b. Remove the bonding cable from the flap tracks.
- c. Remove the bolts from the flap track brackets and remove the flap.

*FLAP INSTALLATION*

- a. Hold flap in position and install the rollers and the bolts in the flap track bracket.
- b. Connect the bonding cable and install the bolt in the flap actuating arm.

**NOTE**

The contour of the flap must be within .0625 inch of the contour of the wing on either or both sides. The inboard trailing edge of the flap must be within .20 inch above or below the trailing edge of the wing stub on either or both sides. The gap between the flap and aileron must be between .13 and .50 inch.

*FLAP TRACK ROLLER INSTALLATION*

Install the rollers (four per flap and two per track) in the flap track brackets with the flanges to the outboard side of the inboard track and to the inboard side of the outboard track. Install a 50-105000-3 washer between each of the aft rollers and its respective track. Use only the wide flanged rollers in the aft locations. The clearance between the roller and the front end of the forward slot in each track must be .03 to .12 inch.

*FLAP CONTROL SYSTEM RIGGING*

(Figure 201)

The flap limit switches are mounted on a bracket and installed on the outboard side of the inboard flap track in the left wing panel. The limit switches, one for up, two for the approach position, and one for down travel, control the travel of the flaps by breaking the circuit to the flap motor at the extreme limits of selected travel. The switches are accessible by lowering the flaps.

**NOTE**

An additional 16° limit switch is installed on serials P-247 and after.

The flap travel is adjusted by moving the limit switches. The left flap is rigged first and then the right flap is synchronized with it. Rig as follows:

Rig the flaps under a simulated flight load to reduce overtravel to a minimum after the limit switches have been adjusted.

- a. Adjust the up limit switch so the flap will stop approximately 3/32 inch from the forward portion of the slot on the inboard flap track.
- b. Adjust the 14° limit (inboard) switch in its mounting slot until the flap is positioned at 14° to 14.5° after the flap has been actuated from the up to takeoff position (15° range). Adjust the 16° limit (outboard) switch(es) in its mounting slot until the flap is positioned at 15.5° to 16° after the flap has been actuated from the down to takeoff position.
- c. Adjust the down limit switch in its mounting slots until it actuates at 28° to 30° of flap travel.
- d. Remove the bolt attaching the right actuator to the right flap.
- e. Turn the jackscrew on the right actuator in or out to align the right flap with the left.
- f. Install the bolt connecting the actuator to the flap.

**CAUTION**

If flaps are removed for any reason the flap actuator switch should be in the "Neutral" position or the main power switch OFF.

**NOTE**

After the flap is completely rigged, adjust the rubber bumper (flap down) installed on the flap and aileron dividing rib. Turn the adjusting screw in or out as required to take out play or stop vibration when the flap is in the up position. A distinct change in sound of the flap motor near the completion of the flap up travel may indicate an excessive outward adjustment of the bumper.

*FLAP FUNCTIONAL GROUND TEST*

- a. Connect a ground power unit (regulated at 28.25 ± .25 VDC) to the aircraft.
- b. Check flap motor amperage during down and up cycles. (Maximum 7.0 amps down; 9.0 amps up.)
- c. If the amperage is exceeded during the up or down cycle, the system must be inspected for excessive friction, rough flap tracks or misrigging.
- d. Avoid continuous operation of the flaps to prevent overheating of the motor.

*FLAP POSITION TRANSMITTER ADJUSTMENT  
(P-4 through P-246)*

(Figure 201)

An adjustable flap position indicator transmitter is installed

# BEECHCRAFT DUKE 60 SERIES MAINTENANCE MANUAL

## FLAP SETTINGS

Approach- 15° from Neutral  
Full Down- 30° from Neutral

1. Flap Motor Gearbox
2. Flap Shaft and Housing
3. Flap Actuator
4. Limit Switches

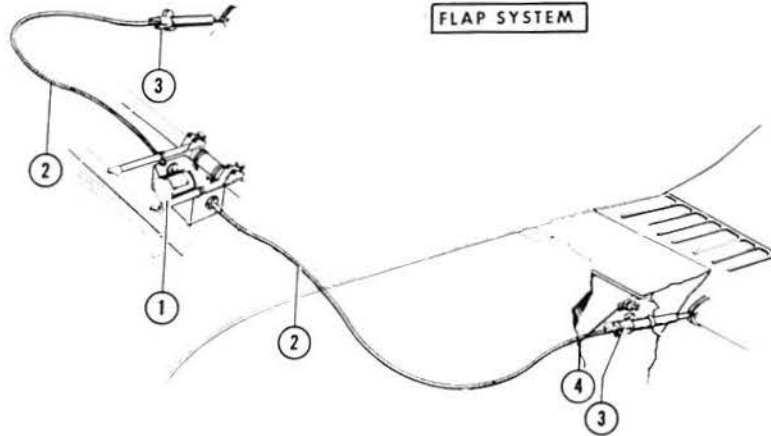

## FLAP SYSTEM

## FLAP TRANSMITTER AND POSITION INDICATORS

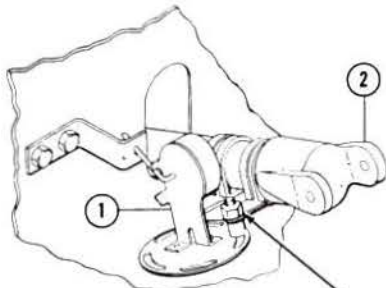

TO ADJUST, LOOSEN MOUNTING BOLTS AND MOVE FORE AND AFT, OR ROTATE SLIGHTLY.

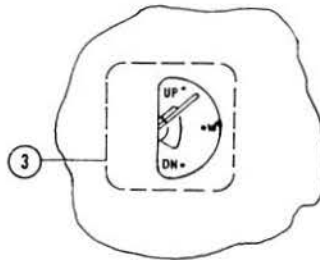

1. Transmitter
2. Flap Actuator

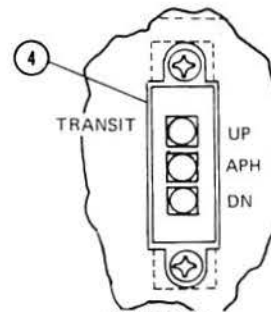

3. Indicator
- \*4. Indicator Lights

## FLAP LIMIT SWITCHES

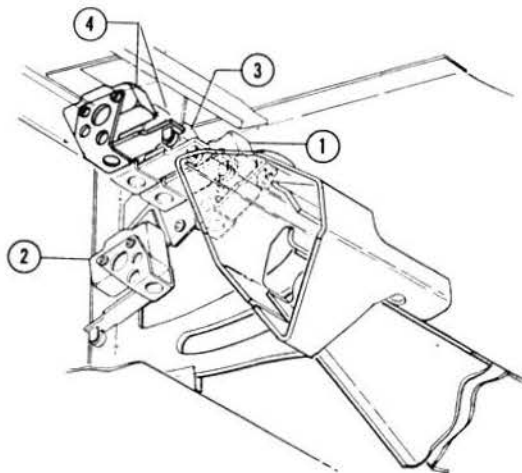

1. Down Limit Switch
2. Up Limit Switch
3. 14° Limit Switch
- \*4. 16° Limit Switches

\*INDICATOR LIGHTS AND (2) 16° LIMIT SWITCHES ARE INSTALLED ON SERIALS P-247 AND AFTER.

60-161-1A

Flap System  
Figure 201

Beechcraft  
DUKE 60 SERIES  
MAINTENANCE MANUAL

## TEMPORARY REVISION NO. 27-2

**Manual Affected:** Duke 60 Series Maintenance Manual (60-590001-25)  
**Filing Instructions:** Insert adjacent to 27-50-00, Page 203, dated Nov 2/73.  
**Reason:** Revise procedures for flap drive cable connection.

### FLAP DRIVE CABLE CONNECTION

Connect the LH and RH flap drive cables to the flap drive motor as follows, using the illustration for component locations:

- a. Install the outboard nut and washer as far as it will go on the threaded portion of the flap cable.
- b. Insert the retainer through the mount support and onto the motor shaft as far as it will go. Align the retainer keyway with the key slot in the flap motor drive shaft and tighten one set screw temporarily.
- c. While inserting the flap cable through the mount support, install the inboard washer and nut. Install the cable through the retainer and into the motor drive shaft until the keyway is just past the key slot in the retainer.
- d. Loosen the set screw that was tightened in Step b. Ensure that the retainer is still installed on the motor shaft as far as it will go and rotate the retainer 90°.
- e. Keep inboard pressure on the retainer and tighten both retainer set screws.
- f. Secure the flap drive cable to the mounting support by tightening the nuts. Tighten the inboard nut to ensure that there is sufficient clearance between the outboard edge of the retainer and the cable housing to allow the retainer to rotate without coming into contact with the cable housing. If the threaded part of the cable housing is not long enough to install the two nuts and washers, using a die, add 5/8-24 UNEF threads until .88 inch thread length is reached. Tighten the outboard nut against the mounting support.

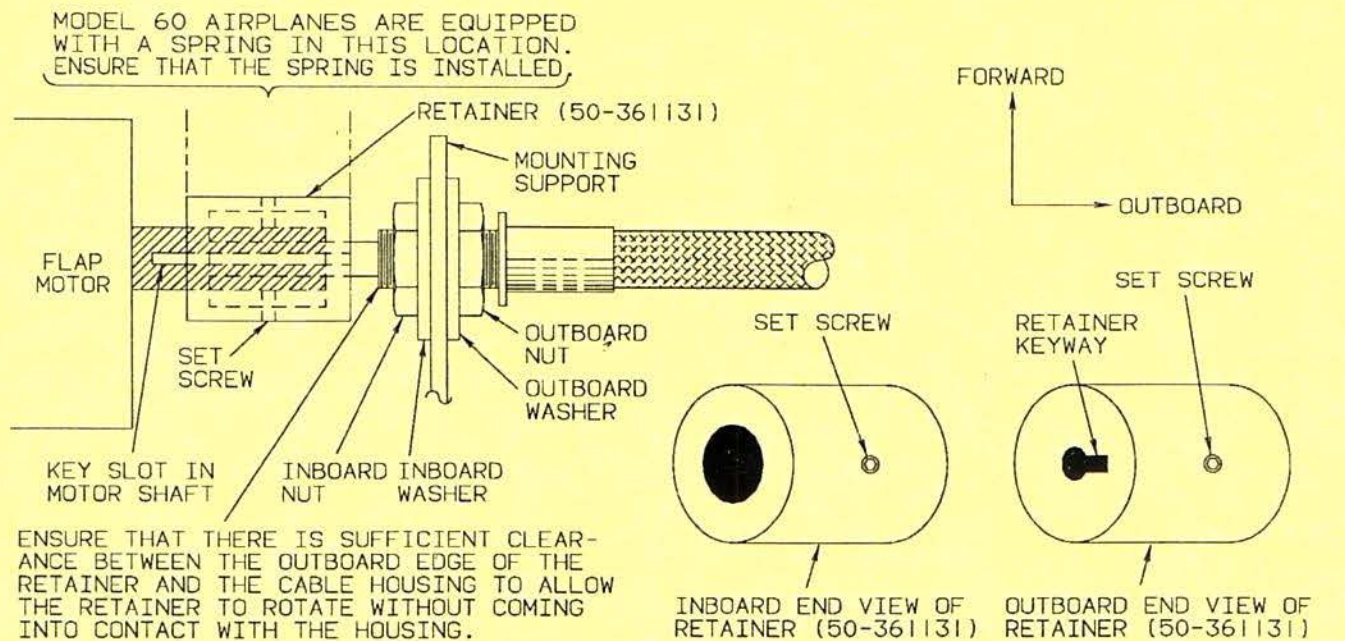

C930#0480116 C





**BEECHCRAFT  
DUKE 60 SERIES  
MAINTENANCE MANUAL**

on the flap actuator in the right wing just forward of the rear spar.

a. Adjust the flap travel limit switches to provide the correct flap travel. (Refer to FLAP CONTROL SYSTEM RIGGING.)

b. Run the flaps down and check the pilot's compartment flap position indicator for 100% flaps. If full down flaps are not indicated, loosen the transmitter attachment bolts and adjust fore and aft or rotate slightly until the reading is correct, then tighten the transmitter attaching bolts.

c. Run the flaps up and check the indicator for up flaps reading.

***FLAP POSITION INDICATOR LIGHTS -  
ADJUSTMENT AND FUNCTIONAL CHECK  
(P-247 and After)  
(Figure 201)***

The flap position indicator lights, installed on the right subpanel, provide the operator with a visual indication of the wing flap position. These lights are controlled by the flap limit switches.

a. Adjust the flap limit switches to provide the correct travel. (Refer to FLAP CONTROL SYSTEM RIGGING.)

b. Select DN (down) position. Observe that the red TRANSIT light illuminates and remains illuminated until the amber DN (down) light illuminates.

c. Select the APH (approach) position. Observe that the amber DN (down) light goes out and the red TRANSIT light illuminates and remains illuminated until the blue APH (approach) light is illuminated.

d. Select the UP (full up) position. Observe that the blue APH (approach) light goes out and the red TRANSIT light illuminates. When the flaps are in UP (full up) position, the red TRANSIT light will go out.

***FLAP ACTUATOR REMOVAL***

a. Fully extend the flaps and disconnect the actuator from the flap.

b. Remove the access plate on the lower surface of the wing and uncouple the flexible drive shaft.

c. Remove the mounting bolts and actuator from the

wing bracket. Remove the bushings from the actuator.

***FLAP ACTUATOR INSTALLATION***

a. Position the actuator in the wing bracket and install the bushings and attaching bolts.

b. Couple the flexible drive shaft to the actuator. Install the access plate on the lower surface of the wing.

c. Extend the actuator until the flap synchronizes with the opposite flap, then connect the actuator to the flap.

d. Check rigging of the wing flap control system.

e. If a new or overhauled actuator is installed, lift lightly on the flap trailing edge while running the flap through a complete extend-retract cycle. There should be no roughness or evidence of binding in the actuator.

***FLAP MOTOR/GEARBOX REMOVAL***

a. Gain access to the flap motor through the cabin floor panel at the rear spar carry through.

b. Disconnect the electrical wiring at the motor.

c. Remove the drive shaft retainers on each side of the gearbox and disconnect both flexible drive shafts from the support bracket.

d. Remove the four bolts, attaching the motor/gearbox to the support bracket, and remove the motor/gearbox as a unit.

***FLAP MOTOR/GEARBOX INSTALLATION***

a. Position the flap motor/gearbox against the support bracket and install the four bolts. Secure the bolts with safety wire.

b. Connect the flexible drive shafts to the gearbox and install the drive shaft retainers.

c. Connect both flexible drive shafts to the support bracket.

d. Degrease the retainer threads with primer (40, Chart 207, 91-00-00). Apply thread locking compound (36, Chart 207, 91-00-00) to the retainers prior to installation.

e. Connect electrical wiring at the motor.

f. Install the cabin floor access panel.

g. Perform a FLAP FUNCTIONAL GROUND TEST.

"END"



**BEECHCRAFT  
DUKE 60 SERIES  
MAINTENANCE MANUAL**

**STALL WARNING SYSTEM - DESCRIPTION  
AND OPERATION**

The stall warning system consists of a stall warning horn mounted forward of the instrument panel; a lift transducer, a lift transducer vane heater element, a face plate heater element on the leading edge of the left wing; a landing gear switch, a circuit breaker, and a stall and pitot switch located on the pilot's subpanel.

When aerodynamic pressure on the lift transducer vane

indicates that a stall is imminent, the transistor switch is actuated to complete the circuit to the stall warning horn. The lift transducer senses the angle of attack and is triggered by reverse air flow.

***CAUTION***

The heater element protects the lift transducer from ice, however, a buildup of ice on the wing may disrupt the airflow and prevent the system from accurately indicating an incipient stall.

"END"



**BEECHCRAFT  
DUKE 60 SERIES  
MAINTENANCE MANUAL**

**TROUBLESHOOTING  
STALL WARNING SYSTEM**

<i>TROUBLE</i>	<i>PROBABLE CAUSE</i>	<i>REMARKS</i>
1. Warning system inoperative.	a. Warning circuit breaker tripped.	a. If circuit breaker persists in tripping, check for grounded circuit.
	b. Open circuit.	b. Check for continuity.
	c. Defective warning horn switch.	c. Replace switch.
	d. Defective warning horn.	d. Replace horn.
2. Horn continues to blow.	a. Defective warning horn switch.	a. Replace switch.

**"END"**



**BEECHCRAFT  
DUKE 60 SERIES  
MAINTENANCE MANUAL**

**STALL WARNING - MAINTENANCE PRACTICES**

**STALL WARNING INDICATOR REMOVAL**

- a. Remove the four screws attaching the doubler and indicator to the lower wing leading edge.
- b. Disconnect electrical wires at the indicator and heater switches.

**STALL WARNING INDICATOR INSTALLATION**

- a. Connect the electrical wires to the indicator and heater switches.
- b. Position the indicator in the opening in the lower wing leading edge, install the doubler and the four screws.
- c. Adjust the indicator. See STALL WARNING INDICATION SYSTEM ADJUSTMENT.

**STALL WARNING INDICATING SYSTEM ADJUSTMENT**

(Figure 201)

The stall warning switch is carefully adjusted when the airplane is test flown at the factory. Should it require readjusting, proceed as follows: Locate the switch installation on the under surface of the left wing leading edge and loosen the two phillips-head screws, one on either side of the vane. If the stall warning has been coming on too early, pull the vane back and down. If the stall warning has been coming on too late, push the vane up and forward. Moving the vane with the phillips-head screws loosened moves the entire unit up or down inside the wing, causing the switch to be closed earlier or later. Retighten the screws after making each adjustment. NEVER TRY TO ADJUST THE SWITCH BY BENDING THE VANE.

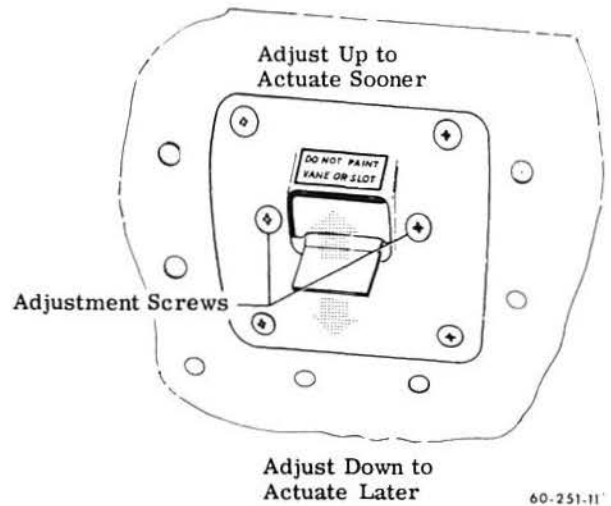

**Stall Vane Adjustment  
Figure 201**

As a rule of thumb, moving the vane 1/4 inch will change the time the stall warning actuates by about 4.4 knots of indicated air speed. The only way to test the accuracy of the setting is to fly the airplane into a stall, noting the speed at which the warning horn comes on and the speed at which the full stall occurs. The stall should be made with the flaps and gear up and power off. Prior to stalling, decelerate no faster than one knot per second. It may be necessary to make several alternate adjustments and test flights before the desired setting can be reached. The stall warning should actuate at 5 to 7 knots ahead of the complete stall. The switch setting should be checked and adjusted as necessary whenever a wing or wing leading edge is replaced or extensively repaired, or if a new switch is installed. The switch should require no adjustment in normal service.

"END"





**BEECHCRAFT  
DUKE 60 SERIES  
MAINTENANCE MANUAL**

**GUST LOCK AND DAMPENER -  
MAINTENANCE PRACTICES**

If it is necessary to park the airplane outside for extended periods, install the control locks and tie down the airplane. Installing control locks may be done as follows:

- a. Insert the spring end of the rudder control locking pin into the hole at the top of the pilot's left rudder pedal arm.
- b. Neutralize the pedals with the locking pin spring compressed and insert the opposite end of the locking pin into the right pedal arm. The rudder pedals locking pin is

placarded RUDDER PEDALS LOCKED.

- c. Position the throttle control lock, placarded THROTTLE CONTROLS STOP, forward of the throttle levers in the closed position and secure it to the console with the Dzus fastener.

- d. The aileron control locking device, placarded AILERON AND ELEVATOR CONTROLS LOCKED, is installed by inserting the pin through a hole in a flange protruding from the subpanel, and through a matching hole in the lower side of the control column tube.

To remove the control locks, remove in the following order: rudder, aileron/elevator and throttle.

"END"

