



CONTINENTAL MOTORS
A Teledyne Technologies Company

Starting Vibrator Assemblies

Form No. X43003-1

TECHNICAL PORTIONS
FAA Approved
April, 2001

©2001 Teledyne Technologies, Incorporated

CURRENT STATUS OF PAGES AS OF:

April, 2001

See "Manual Revisions," in the introduction section for distribution procedure.

THE ORIGINAL DATE OF THIS PUBLICATION IS *April, 2001*.

INSERT LATEST PAGES, DESTROY SUPERSEDED PAGES.

WARNING

If the user of this manual is uncertain whether all current revisions have been incorporated into the manual, contact Teledyne Continental Motors. Do not perform any operation, maintenance, installation or other operation until the manual is confirmed as current.

Starting Vibrator Assemblies

FORM X-43003-1

PAGE STATUS	PAGE STATUS	PAGE STATUS	PAGE STATUS

Table of Contents

<i>Introduction</i>	<i>Chapter 1</i>
<i>Airworthiness Limitations</i>	<i>Chapter 2</i>
<i>Description and Operation</i>	<i>Chapter 3</i>
<i>Test</i>	<i>Chapter 4</i>
<i>Repair</i>	<i>Chapter 5</i>
<i>Installation</i>	<i>Chapter 6</i>
<i>Illustrated Parts List</i>	<i>Chapter 7</i>

INTENTIONALLY

LEFT

BLANK

Chapter 1

Introduction

<i>Introduction</i>	<i>1-3</i>
<i>Related Publications</i>	<i>1-3</i>
<i>Slick Service Information</i>	<i>1-3</i>
<i>ASTM</i>	<i>1-3</i>
<i>About This Manual</i>	<i>1-3</i>
<i>Replacement Parts</i>	<i>1-4</i>
<i>Know Your Supplier</i>	<i>1-4</i>
<i>Identifying Approved Parts</i>	<i>1-4</i>

INTENTIONALLY

LEFT

BLANK

Introduction

This manual provides complete maintenance instructions with illustrated parts lists for starting vibrator assemblies manufactured by Teledyne Continental Motors, Aircraft Products, Mobile, Alabama, 36601.

Considerable effort has been made to provide clear and accurate information. Teledyne Continental Motors solicits your input regarding revisions and additional information for our manuals. Please forward your comments and input to:

Teledyne Continental Motors
P.O. Box 90
Mobile, Alabama 36601
Attn: Publications Department

Related Publications

The following is a list of related manuals and service information:

- Starter Service Instructions, Form X30592
- TCM Ignition Systems Service Bulletins, Form X40000SBS

All TCM manuals and service information can be ordered through your Teledyne Continental Motors distributor or (if prepaid) directly from:

Teledyne Continental Motors
Aircraft Products
P.O. Box 90
Mobile, AL 36601

For price information on the above publications, request the TCM Publications Pricing Index of Current Publications and Optional Publications.

Slick Service Information

Order Slick Ignition Systems' Master Service Manual Index and Order Form No. F-1100. Order from:

Slick Aircraft Products
Unison Industries
530 Blackhawk Park Avenue
Rockford, Illinois 61104
Attn: Subscription Department
Tele: (815) 965-4700

ASTM

American Society for Testing and Materials
Order through:

ASTM
1916 Race Street
Philadelphia, PA
19103-1187 USA
Tele: (215) 299-5400

About This Manual

This manual does not cover all the details or variations in equipment nor does it provide for every possible contingency that may be encountered in the installation, operation or maintenance of starting vibrator assemblies.

Should further information be required or if problems arise which are not covered sufficiently, see your TCM distributor or TCM field representative.

Replacement Parts

WARNING

Beware of replacement parts, materials and accessories that may be sold as aircraft quality but whose origin and quality are not known. These parts may be deceptively advertised as “unused,” “like new,” or “remanufactured,” and purchasers are often unaware that they are not eligible for use on certificated aircraft.

All replacement parts must have an 8130-3 Airworthiness Approval Tag.

Know Your Supplier

Many original parts and components are copied and the copies are sold at discounted prices for installation on U.S. certified aircraft. An original manufacturer's part is often used as a guide to make duplicates that appear to be as good as the original, but there are many unknowns about the quality of design, materials, and workmanship. Other factors that go into quality parts are the degree of heat treating and plating, and inspections, tests, and calibrations. Unfortunately, a cheaply produced part that looked “as good as the original” is usually found out too late.

Federal Aviation Regulations FAR 43.13 and FAR 145.57 specify performance rules for replacement of parts and materials used in the maintenance and alteration of United States certificated aircraft. FAR 91.403, FAR 121.363, FAR 123.45, and FAR 135.143(a) holds the owner/operator responsible for the continued airworthiness of the aircraft, and that includes the quality of replacement parts.

Identifying Approved Parts

Approved serviceable replacement parts are identified by:

1. Federal Aviation Administration (FAA) Form 8130-3 Airworthiness Approval Tag. An Airworthiness Approval Tag identifies a part or group of parts that have been approved by an authorized FAA representative.
2. FAA Technical Standard Order (TSO) number and identification mark indicating that the part or appliance was manufactured in accordance with the requirements of FAR 21 Subpart O.
3. FAA Parts Manufacturer Approval (PMA) symbol with the manufacturer's name, part number, make and model of the type certified product on which the part can legally be installed stamped on the part. An FAA/PMA is issued under FAR 21.305. Make and model information may be on a tag attached to the part.
4. Shipping ticket, invoice, or other document which verifies that the part was manufactured by a facility that was holding an FAA Approved Production Inspection System Certificate issued under FAR 21 Subpart F, or by a manufacturer holding an FAA Production Certificate issued under FAR 21 Subpart G.
5. Certificate of airworthiness for export issued by governments in countries other than the United States of America under the provisions of FAR 21 Subpart N.

Chapter 2

Airworthiness Limitations

This Airworthiness Limitations Page is F.A.A. approved and specifies maintenance required by the Federal Aviation Regulations unless an alternative program has been F.A.A. approved. This section is part of the type design of the starting vibrator assemblies pursuant to certification requirements of the Federal Aviation Regulations.

1. **Mandatory Replacement Times**
Subject to additional information contained in F.A.A. Approved Mandatory Service Bulletins issued after the date of certification, the Teledyne Continental Motors starting vibrator assemblies do not contain any components having mandatory replacement times required for type certification.
2. **Mandatory Inspection Intervals**
Subject to additional information contained in F.A.A. Approved Mandatory Service Bulletins issued after the date of certification, no inspections mandated by the Federal Aviation Regulations are required for type certification.
3. **Other Mandatory Intervals**
Refer to "Related Publications" in Chapter 1 for information about ordering relevant manuals.
4. **Other Related Procedures**
Subject to additional information contained in F.A.A. Approved Mandatory Service Bulletins issued after the date of certification, the vibrator does not have any inspection-related or replacement time-related procedures required for type certification.
5. **Distribution of Changes to Airworthiness Limitations**
Changes to this Airworthiness Limitations Chapter constitute changes to the type design of the starting vibrator assemblies and require F.A.A. approval pursuant to Federal Aviation Regulations. Such changes will be published in F.A.A. Approved Mandatory Service Bulletins, TCM Service Bulletins and can be obtained by writing TCM, P.O. Box 90, Mobile, Alabama 36601.

INTENTIONALLY

LEFT

BLANK

Chapter 3

Description and Operation

<i>Description and Operation</i>	3-3
<i>Starting Vibrator</i>	3-6
<i>Starting Vibrator With Relay</i>	3-8
<i>Starting Vibrator With Relay And Delay</i>	3-10

Illustrations

<i>Figure 3-1, Typical Ignition System With Starting Vibrator</i>	3-5
<i>Figure 3-2, Typical Ignition System With Starting Vibrator With Relay</i>	3-7
<i>Figure 3-3, Typical Ignition System With Starting Vibrator With Relay and Delay</i>	3-9

INTENTIONALLY

LEFT

BLANK

Description and Operation

Starting vibrators, available in 12 and 24 volt models, eliminate the need for impulse couplings used on many magnetos.

The vibrator is mounted on the airframe via a bracket which forms part of the vibrator mounting plate. A plastic can-type cover snaps onto the vibrator mounting plate. The vibrator boosts electrical energy available to the magneto coil in order to create high voltage necessary to fire the spark plugs at low cranking speeds.

The vibrator provides interrupted battery voltage to the magneto primary coil. This pulsating DC voltage is then stepped up by transformer action, producing a shower of sparks at the spark plug for improved starting.

Starting vibrators which incorporate a relay usually use separate ignition switches and starter switches. Vibrators that do not use a relay require the use of the TCM, or similar, combination ignition and starter switch. The relay grounds the right magneto during starting, connects the retard breaker assembly to the main breaker assembly and energizes the starter circuit. Vibrators that incorporate a relay have five terminals on the mounting plate. Relays that do not incorporate a relay have two terminals.

Starting vibrators with a relay and delay feature hold the vibrator on line for a fraction of a second after the start signal ends. Relay/delay vibrators are distinguished by the instruction "Bond vibrator bracket to the airframe ground" printed on the data plate.

The tables "Vibrator Without Relay," "Vibrator With Relay," and "Vibrator With Relay & Delay" on the following page list the available vibrators and their operating voltages, input currents, and applications. Part numbers 10-357487-241, 10-

357487-242 and 10-382808-24 are 24 volt vibrators which incorporate a balance coil and insulated vibrator coil.

Refer to the following diagrams:

- Figure 3-1, "Typical Ignition System With Starting Vibrator."
- Figure 3-2, "Typical Ignition System With Starting Relay (Pushbutton Start Switch)."
- Figure 3-3, "Typical Ignition System With Starting Vibrator With Relay And Delay."

WARNING

In Figures 3-1 through 3-3, all switches and relays are in the normal "OFF" position. These diagrams illustrate the electrical operations of the magneto circuits. They are not to be used for installation purposes.

Description and Operation

Vibrator Without Relay			
Part Number	System Voltage	Input Current (Amps Max.)	Application
10-176487-121	12	2.5	S-200, S-600
10-176487-122	12	2.0	S-1200
10-357487-241	24	2.5	S-200, S-600
10-357487-242	24	2.0	S-1200
10-382775-12	12	3.0	D-2200, D-3200
10-382808-24	24	3.0	D-2200, D-3200
Vibrator With Relay			
10-400608-121	12	2.5	S-200, S-600
10-400608-122	12	2.0	S-1200
10-400608-123	12	3.0	D-2200, D-3200
10-400608-241	24	2.0	S-1200
10-400608-242	24	2.5	S-200, S-600
10-400608-243	24	3.0	D-2200, D-3200
Vibrator With Relay & Delay			
10-400523-1	12	2.5	DA-20 Diamond Katana

Table 3 – 1

Starting Vibrator Specifications

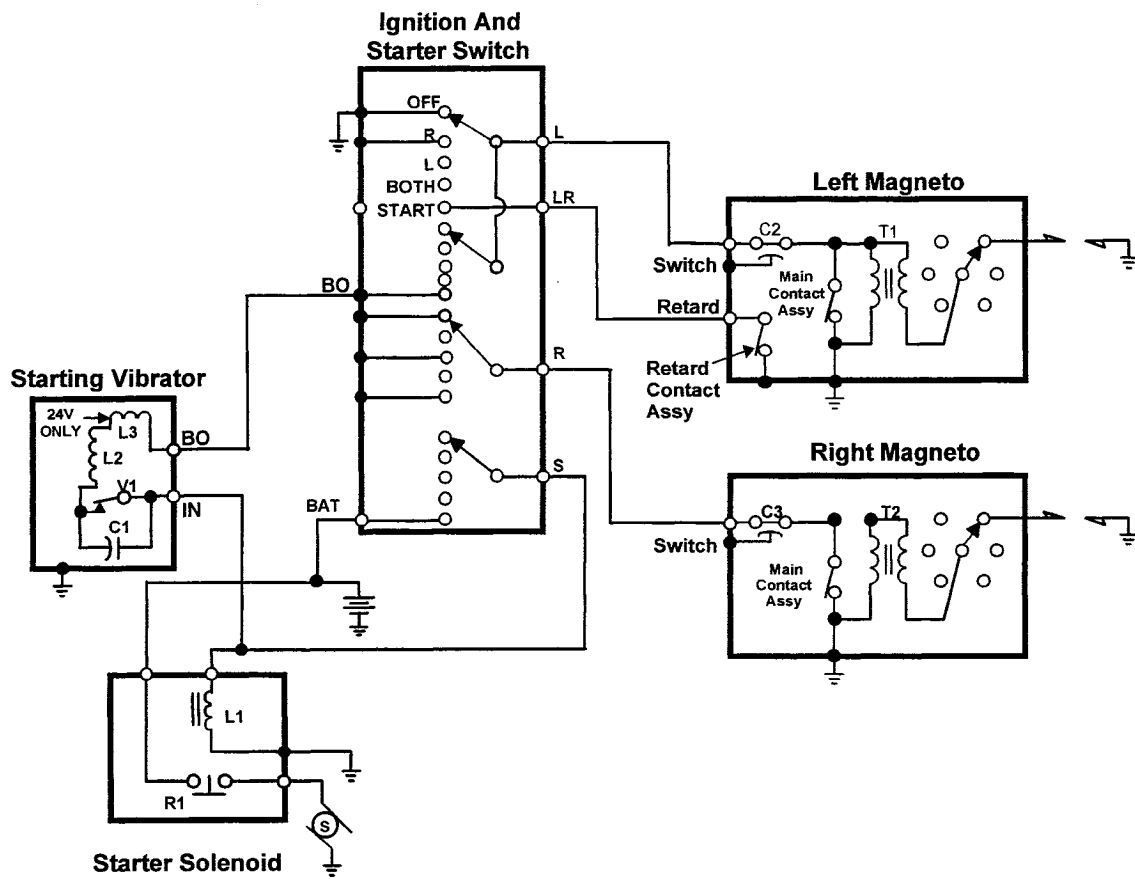

Figure 3-1
Typical Ignition System With Starting Vibrator

Starting Vibrator

With the combination ignition and starter switch in its "START" position (Figure 3-1 on the preceding page), the right magneto is grounded. Starter solenoid L1 is energized, closing its relay contact R1. Battery current flows through vibrator points V1, coil L2 (an L3 in 24 volt models), through the switch and main and retard breakers of the left magneto to ground. A magnetic field built up around coil L2 causes vibrator points V1 to open. Current ceases in the circuit, causing the magnetic field to collapse and vibrator points to re-close. Current flow resumes and re-energizes coil L2. Vibrator points V1 open again. When the engine reaches its normal advance firing position, the main contact assembly opens. However, the vibrator current is still carried to ground through the retard contact assembly which does not open until the starting

retard position of the engine is reached. On all systems, when the retard contact assembly opens (main contact assembly is still open), the vibrator current flows through the primary of transformer T1, producing a magnetic field around the coil. As the vibrator points V1 open, current flow through the primary of transformer T1 ceases. This causes a high voltage to be induced in the secondary which fires the spark plug. A shower of sparks is produced at the spark plug due to this opening and closing of the vibrator points V1 while the main and retard contact assemblies are open.

When the engine fires and begins to increase speed, the ignition and starter switch is released and automatically returns to the "BOTH" position. This opens the vibrator and starter circuits, rendering them inoperative. The right magneto is no longer grounded and both magnetos are firing simultaneously in full advance.

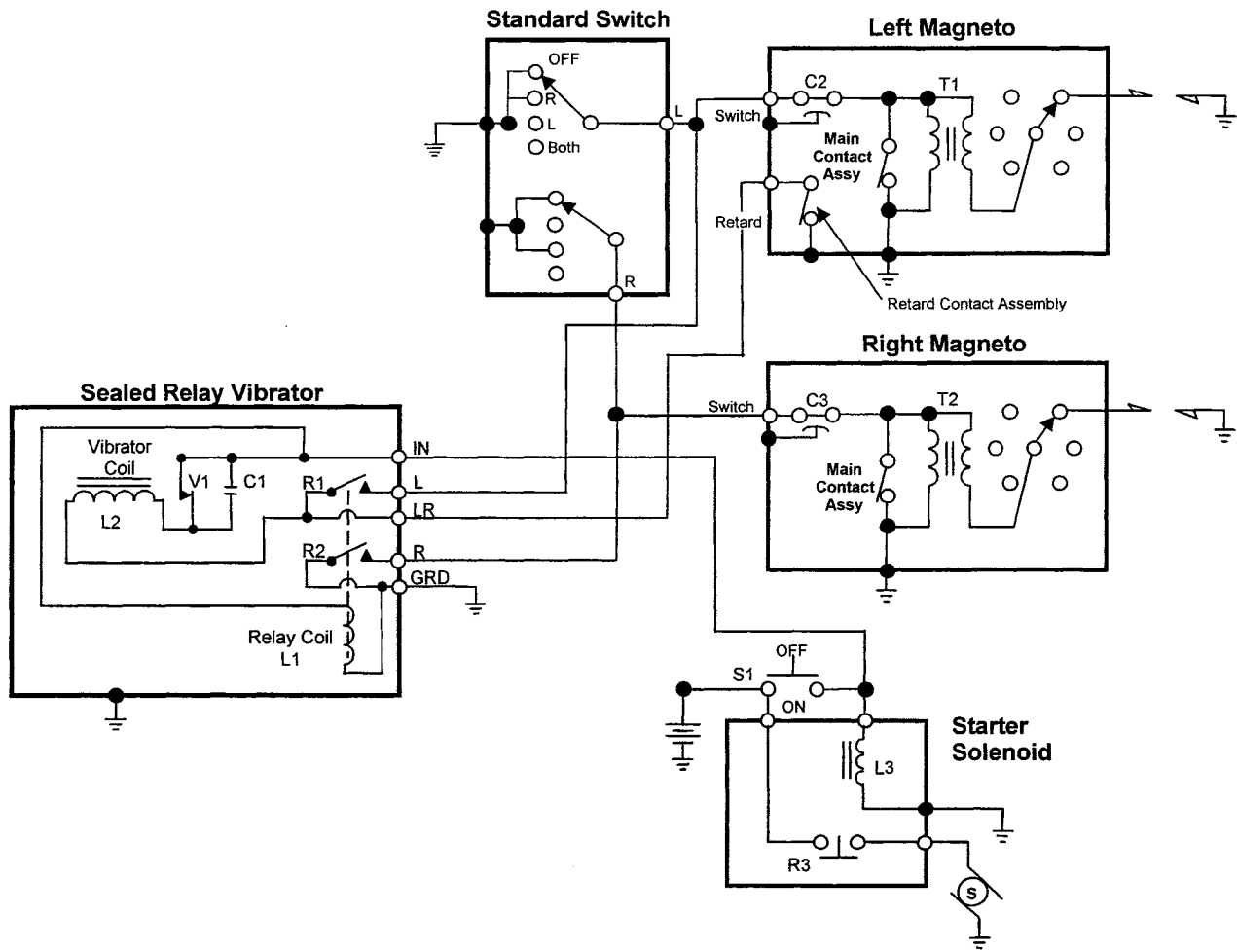

Figure 3-2
Typical Ignition System With Starting Vibrator With Relay

Starting Vibrator With Relay

With the ignition switch in the "BOTH" position (Figure 3-2) and the starter switch S1 in the ON position, starter solenoid L3 and coil L1 are energized, closing their relay contacts R1, R2 and R3. Relay contact R2 connects the right magneto to ground, rendering it inoperative during starting (this is why the magneto switch is placed in the BOTH position for starting). Battery current flows through vibrator points V1, coil L2, through retard contact assembly of left magneto to ground as well as through relay contact R1 and through main contact assembly to ground. A magnetic field around coil L2 produced from this current causes vibrator points V1 to open. Current stops flowing through coil L2 causing the magnetic field to collapse and vibrator points V1 to re-close. This allows coil L2 to energize and vibrator points V1 again to open. This interrupted battery current will be carried to ground through the main and retard contact assemblies.

When the engine reaches its normal advance firing position, the main breaker assembly of the left magneto opens. However, vibrator current is still carried to ground through the retard contact assembly, which does not open until starting retard position of engine is reached. When the retard contact assembly opens (main contact assembly is still open), vibrator current flows through the primary of transformer T1 (magneto coil) producing a magnetic field around the coil. As the vibrator points V1 open, current flow through the primary of transformer T1 ceases. This induces a high voltage in the secondary which fires the spark plug. A shower of sparks is therefore produced at the spark plug due to this opening and closing of vibrator points V1 while the main and retard contact assemblies are open.

When the engine fires and begins to increase speed, the starter switch is released and in turn relay coil L1 and starter solenoid L3 are energized. This opens the vibrator and retard contact assembly circuits, rendering them inoperative. The

right magneto is no longer grounded and thus both magnetos are simultaneously firing in full advance.

Starting Vibrator With Relay And Delay

With the combination ignition and starter switch in its "START" position (Figure 3-3 on the following page) starter solenoid L3 and coil L1 are energized, closing their relay contacts R1, R2, R3 and R4. Capacitor C2 is charged. Relay contact R3 connects the right magneto to ground, rendering it inoperative during starting procedures. Battery current flows through relay contact R1, vibrator points V1, coil L2, through retard contact assembly of left magneto to ground, as well as through relay contact R2 and through the left magneto main contact assembly to ground. A magnetic field around coil L2 produced from this current causes Vibrator points V1 to open. Current stops flowing through coil L2 causing the magnetic field to collapse and vibrator points V1 to re-close. This allows coil L2 to energize and vibrator points V1 again to open. This interrupted battery current will be carried to ground through the main and retard contact assemblies.

When the engine reaches its normal advance firing position, the main breaker assembly of the left magneto opens. However, vibrator current is still carried to ground through the retard contact assembly, which does not open until starting retard position of engine is reached. When the retard contact assembly opens (main contact assembly is still open), vibrator current flows through the primary of transformer T1 (magneto coil) producing a magnetic field around the coil. As the vibrator points V1 open, current flow through the primary of transformer T1 ceases. This induces a high voltage in the secondary which fires the spark plug. A shower of sparks is therefore produced at the spark plug due to this opening and closing of vibrator points V1 while the main and retard contact assemblies are open.

When the engine fires and begins to increase speed, the starter switch is released and the starter solenoid L3 is de-energized. Capacitor C2 discharges through coil L1 (its path through L3 is

blocked by diode D1), holding in the relay for a fraction of a second. When capacitor C2 is discharged, L1 is de-energized. This opens the vibrator and retard contact assembly circuits, rendering them inoperative. The right magneto is no longer grounded and thus both magnetos are simultaneously firing in full advance.

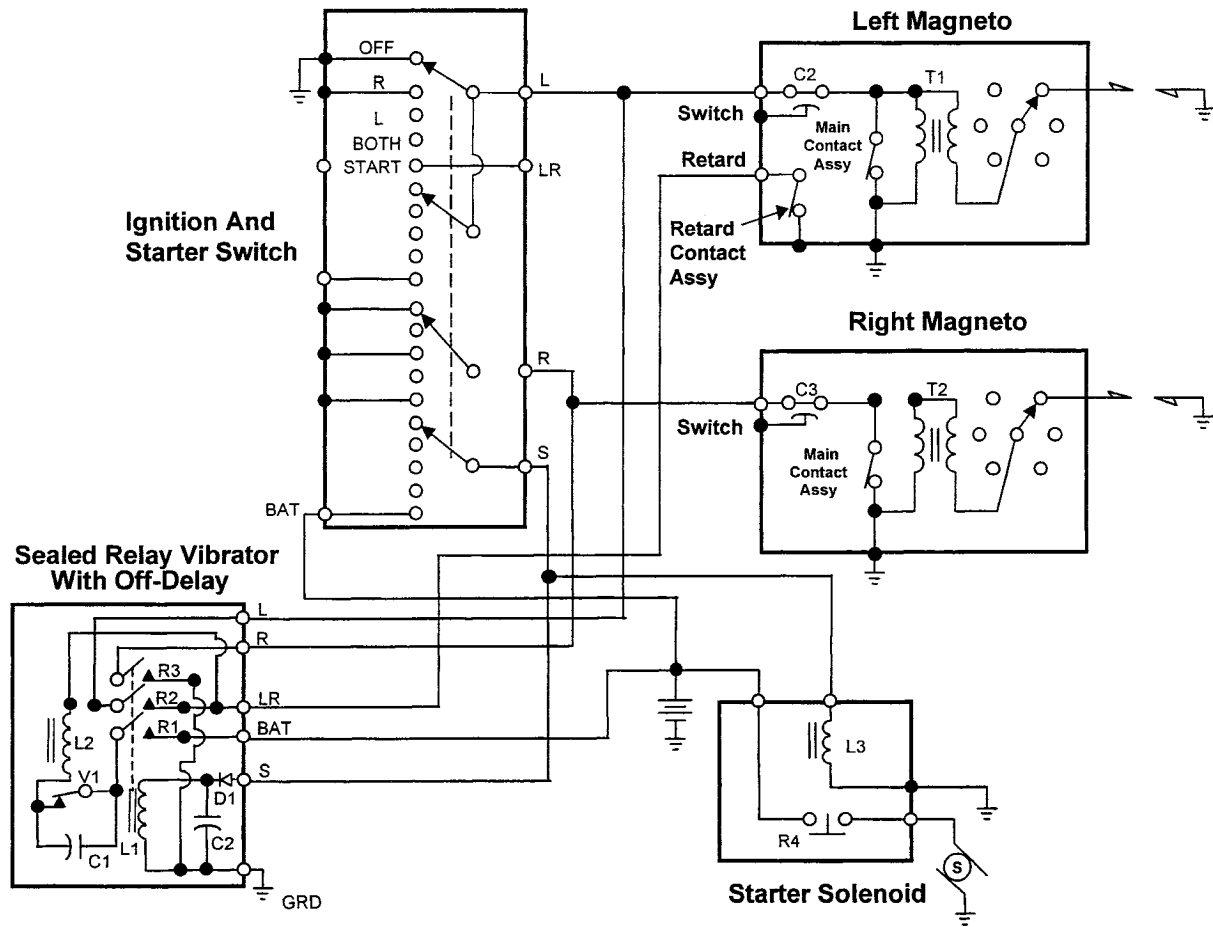

Typical Ignition System with Relay and Delay Including Starting Vibrator

Figure 3-3

Typical Ignition System With Starting Vibrator with Relay and Delay

Chapter 4

Test

<i>Test Equipment Required</i>	4-3
<i>Checking Starting Vibrator</i>	4-3
<i>Checking Starting Vibrator With Relay</i>	4-4
<i>Checking Starting Vibrator With Relay and Delay</i>	4-6

Illustrations

<i>Figure 4-1, Test Setup For Starting Vibrator</i>	4-3
<i>Figure 4-2, Test Setup For Starting Vibrator With Relay</i>	4-5
<i>Figure 4-3, Test Setup For Starting Vibrator With Relay and Delay</i>	4-6

INTENTIONALLY

LEFT

BLANK

Test Equipment Required

1. Bendix/TCM S-200, S-600 and secondary coil, S-1200, D-2200 and D-3200, Slick 4300 Series Magnetos as applicable.
2. Power Supply
Battery or variable, filtered DC, 0 – 30 volts, maximum 2% ripple.
3. Ammeter
0 – 5 ampere range, DC meter $\pm 2\%$ accuracy.
4. Voltmeter
0 – 30 volts DC meter $\pm 2\%$ accuracy.
5. Switches
 1. Single pole, single throw, min. 30V, 5 amp. rating.
 2. Single pole, double throw, min. 30V, 5 amp. rating.
6. Ohmmeter, Fluke Model 45 or equivalent.

Checking Starting Vibrator

Refer to illustrated parts list and “Starting Vibrator Exploded View” in Chapter 7, Illustrated Parts List.

1. Use test equipment outlined under “Test Equipment Required” above.
2. Connect vibrator terminal “IN” to an ammeter and a voltmeter and through an SPST switch to power source.
3. Connect a 5mm spark gap to number one cylinder outlet of magneto.
4. Insure that all ground leads are connected to a common ground.
5. Rotate magnet shaft until magneto is in number one cylinder firing position.
6. With 12 volt vibrator in circuit, gap should fire consistently with both 8 VDC and 15 VDC applied as input to the vibrator.

Continued...

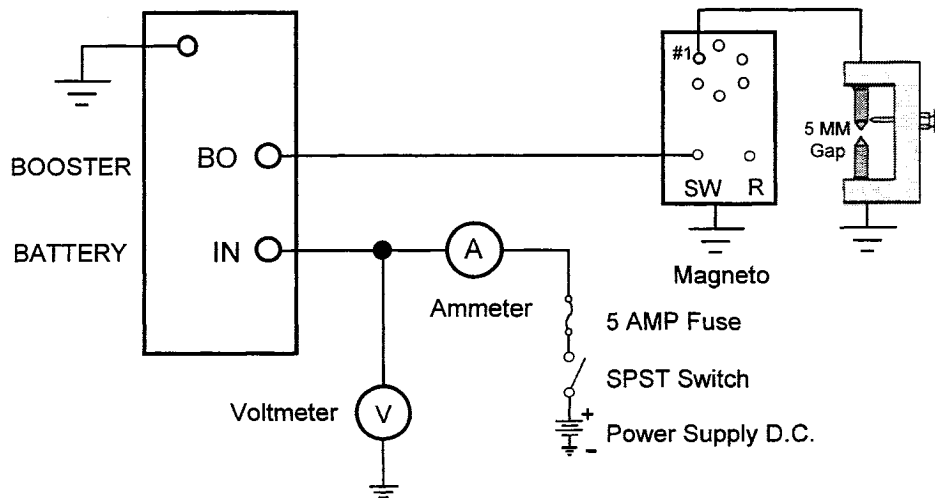

Figure 4-1
Test Setup For Starting Vibrator

7. With 24 volt vibrator in circuit, gap should fire consistently with both 13 VDC and 30 VDC applied as input to the vibrator.
8. During this test, input current of vibrators must not exceed the maximum current listed in Table 3.1, "Starting Vibrator Specifications."
9. Vibrator input current adjustment is accomplished by adjusting the spring tension of contact assembly as follows:
 - a. Use a suitable tool to bend down the protruding end of support (37) thereby increasing the spring tension between contact assemblies (10) and (19).
 - b. Adjust tension until correct input current is obtained.
10. Recheck contact alignment and air gap as follows:

Insert a 0.025 feeler gauge between bottom of contact assembly (10) and top of vibrator coil core. With contacts properly aligned and touching, press down on contact assembly (19) until feeler gauge just fits between coil core and contact assembly (10). Hold contact assembly (19) in position to ensure contact alignment and vibrator point air gap clearance and tighten adjustable contact securing screw (16). Remove feeler gauge. Final check air gap and contact alignment and then torque screw (16) to 13-15 inch pounds. Recheck air gap clearance. Refer to Figure 5-1.

Checking Starting Vibrator With Relay

Refer to illustrated parts list and "Starting Vibrator Exploded View" in Chapter 7, "Illustrated Parts List."

1. Use test equipment outlined under "Test Equipment Required" above.
2. Connect vibrator terminals "L" and "LR" through an SPDT switch to "SW" terminal of magneto. See Figure 4-3.
3. Connect vibrator terminal "IN" to an ammeter and a voltmeter, and through an SPST switch to power source.

4. Connect a 5mm spark gap to number one cylinder outlet of magneto.
5. Insure that all ground leads are connected to a common ground.
6. Rotate magnet shaft until magneto is in number one cylinder firing position. Apply voltage to starting vibrator as follows:
 - a. With 12 volt vibrator in circuit, gap should fire consistently with both 8 VDC and 15 VDC applied as input to the vibrator.
 - b. With 24 volt vibrator in circuit, gap should fire consistently with both 13 VDC and 30 VDC applied as input to the vibrator.
7. During this test, input current of vibrators must not exceed the maximum current listed in Table 3.1, "Starting Vibrator Specifications."
8. Vibrator input current adjustment is accomplished by adjusting the spring tension of contact assembly as follows:
 - c. Use a suitable tool to bend down the protruding end of support (37) thereby increasing the spring tension between contact assemblies (10) and (19).
 - d. Adjust tension until correct input current is obtained.
9. Recheck contact alignment and air gap as follows:

Insert a 0.025 feeler gauge between bottom of contact assembly (10) and top of vibrator coil core. With contacts properly aligned and touching, press down on contact assembly (19) until feeler gauge just fits between coil core and contact assembly (10). Hold contact assembly (19) in position to ensure contact alignment and vibrator point air gap clearance and tighten adjustable contact securing screw (16). Remove feeler gauge. Final check air gap and contact alignment and then torque screw (16) to 13-15 inch pounds. Recheck air gap clearance. Refer to Figure 5-1.

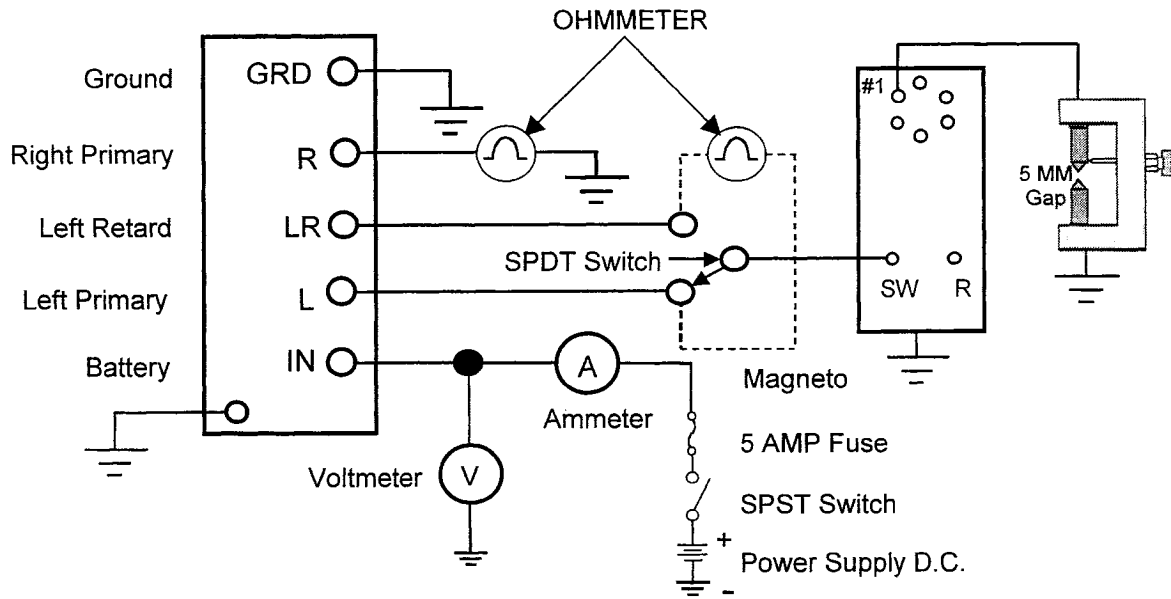

Figure 4-2
Test Setup For Vibrator With Relay

Checking Starting Vibrator with Relay and Delay

Refer to illustrated parts list and “Starting Vibrator Exploded View” in Chapter 7, “Illustrated Parts List.”

1. Use test equipment outlined under “Test Equipment Required” above.
2. Connect vibrator terminals “L” and “LR” through an SPDT switch to “SW” terminal of magneto. See Figure 4-3.
3. Connect vibrator terminals “S” and “BAT” to an ammeter and a voltmeter and through an SPST switch to power source.
4. Connect a 5mm spark gap to number one cylinder outlet of magneto.
5. Insure that all ground leads are connected to a common ground.
6. Rotate magnet shaft until magneto is in number one cylinder firing position. Apply voltage to starting vibrator as follows:

With 12 volt vibrator in circuit, gap should fire consistently with both 8 VDC and 15 VDC applied as input to the vibrator.

7. During this test, input current of vibrators shall not exceed 2.5 amps.
8. Vibrator input current adjustment is accomplished by adjusting the spring tension of contact assembly as follows:
 - a. Use a suitable tool to bend down the protruding end of support (37) to increase the spring tension between contact assemblies (10) and (19).
 - b. Adjust tension until correct input current is obtained.
9. Recheck contact alignment and air gap as follows:

Insert a 0.025 feeler gauge between bottom of contact assembly (10) and top of vibrator coil core. With contacts properly aligned and touching, press down on contact assembly (19) until feeler gauge just fits between coil core

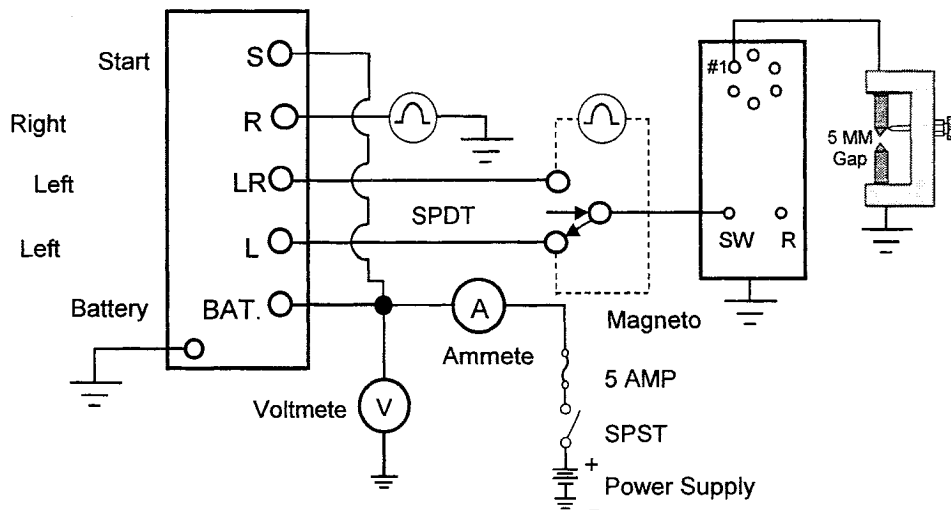

Figure 4-3
Test Setup For Starting Vibrator With Relay And Delay

and contact assembly (10). Hold contact assembly (19) in position to ensure contact alignment and vibrator point air gap clearance and tighten adjustable contact securing screw (16). Remove feeler gauge. Final check air gap and contact alignment and then torque screw (16) to 13-15 inch pounds. Recheck air gap clearance. Refer to Figure 5-1.

10. While maintaining voltage applied to the vibrator, use an ohmmeter to check for continuity between vibrator terminal "R" and ground. There must be continuity.
11. While power is off and the relay is de-energized, use an ohmmeter to check for continuity between vibrator terminal "R" and ground and between terminals "L" and "LR". There must not be continuity.
12. For vibrators with relay and delay, a noticeable delay should be observed between de-energizing the vibrator and the cessation of vibrator action (approximately 0.1 second minimum). If this delay is not observed, replace the vibrator.

CAUTION...

Do not connect ohmmeter across terminals "L" and "LR" while voltage is applied to the vibrator.

INTENTIONALLY

LEFT

BLANK

Chapter 5

Repair

<i>Special Tools Required</i>	5-3
<i>Component Testing</i>	5-3
<i>Setting Contact Gap</i>	5-4
<i>Leakage and Capacitance</i>	5-5
<i>Relay Vibrator Bushing Repair</i>	5-7

Illustrations

<i>Figure 5-1, Aligning Contact Points</i>	5-4
<i>Figure 5-2, Starting Vibrator</i>	5-5
<i>Figure 5-3, Starting Vibrator With Relay</i>	5-6
<i>Figure 5-4, Starting Vibrator With Relay And Delay</i>	5-6
<i>Figure 5-5, Relay Vibrator Bushing Repair</i>	5-7

INTENTIONALLY

LEFT

BLANK

Special Tools Required

1. LC103 Capacitor tester available from Sencore, 3200 Sencore Drive, Sioux Falls, S.D. 57107
2. Model 45A Digital Multimeter, John Fluke Mfg. Co., P.O. Box C-9090, Everett WA 98206.

Component Testing

1. Unsnap cover from vibrator mounting plate.
2. Clean all vibrator parts with dry air blast.

Note:

The most common cause of vibrator failure is coil burnout, usually the result of arcing or fused points. Therefore, the initial repair procedures investigate the possibility of coil failures.

3. Check contact assembly vibrator points for wear and excessive arcing.
4. Check vibrator coil and balance coil (if used) for proper resistance.
5. Before checking vibrator coil, insulate vibrator points to insure that there is no contact between them. Resistance of 12 or 24 volt coils should be less than 1.0 ohm. In vibrators that incorporate balance coils, test both coils simultaneously by connecting an ohm meter between the BO terminal and the stationary vibrator contact point. If resistance measured is not less than 1.0 ohm, replace the entire vibrator assembly.
6. If the vibrator points are fused, remove the contact assemblies as follows:
 - a. Remove screw, plain washer, lock washer and contact assembly from coil support.
 - b. Remove top nut, terminals attached to capacitor lead, coil lead, remaining nut, plain washer, contact assembly, insulating washer, screw with plain washer and bushing from coil support.
7. Test coil for values outlined paragraph 3 above.
8. If the coil does not have continuity or does not indicate the correct resistance, replace the complete vibrator assembly.
9. For vibrators that incorporate a relay:
 - a. Check relay coil for continuity and resistance with an ohmmeter. Resistance of 12 volt relay coils should be 75 ohms $\pm 10\%$. 24 volt coils should be 200 ohms $\pm 10\%$. If the relay does not have the correct amount of resistance, replace the complete vibrator assembly.
 - b. Energize the relay coil with a variable 0-15 DC source. Contacts should close at or below 6.5 volts DC for 12 volt relays and at or below 13 volts DC for 24 volt relays. If the relay does not meet these limits, replace the entire vibrator assembly.
10. If inspection indicates that the contact points may be usable after resurfacing, dress them with a fine oil stone. When dressing points for pits, do not try to remove pits completely. Dress points only enough to remove ridges around pits and to level point surfaces. Usually, when the point surface is level, enough contact area remains around the pit to provide efficient point operation. When dressing points for mounds, each mound must be completely stoned off, leaving the surface of the point smooth and flat. Clean contacts thoroughly with a suitable solvent.
11. If the vibrator contacts are not fit for further service, replace the contact assemblies in accordance with the following procedure:
 - a. Position contact assembly securing screw, with plain washer and bushing attached, through hole in coil support.

- b. Place insulating washer, new contact assembly, plain washer, and one nut on screw.
- c. Position contact assembly over center of coil core and tighten nut. Torque screw to 10-12 inch pounds.
- d. Position new contact assembly in line with appropriate hole in coil support and secure with screw, lock washer, and plain washer. See Figure 5-1, "Aligning Contact Points."

Setting Contact Gap

To properly gauge vibrator contacts for correct air gap:

1. Insert a 0.025 feeler gauge between the bottom of the contact assembly and the top of the vibrator coil core.
2. With the contacts properly aligned and touching, press down on the contact assembly. Hold contact assembly in position to ensure contact alignment and vibrator point air gap clearance and tighten adjustable contact securing screw.
3. Remove the feeler gauge.
4. Perform a final air gap and contact alignment check.
5. Torque screw to 13-15 inch pounds.
6. Recheck air gap clearance. Refer to Figure 5-1, "Aligning Contact Points."

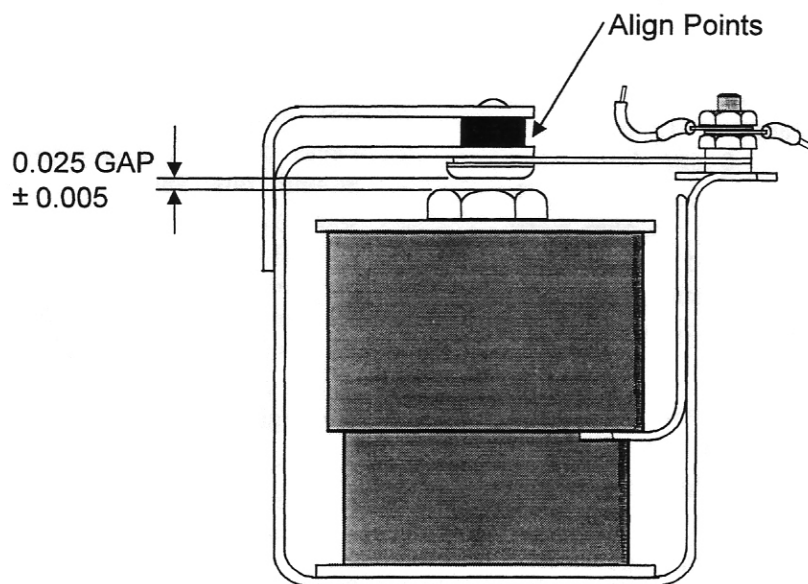

Figure 5-1
Aligning Contact Points

Leakage and Capacitance

Check leakage and capacitance of capacitor using the LC103 Capacitor Tester or equivalent.

1. Insulate vibrator contact points to ensure that there is no contact between them.
2. Connect the test leads of tester to the capacitor lead and housing ground. Capacitance shall be 0.38 to 0.53 microfarads. Capacitor may leak up to 8 mA at 400 vdc. Reject capacitors that fail this test.
3. To remove the capacitor, unscrew and remove screw with lock washer and capacitor from support.
4. Mount new capacitor in position on support and secure using the screw with lock washer.
5. Place capacitor terminals and coil lead on screw and secure with nut. Torque nut to 10-12 inch pounds.
6. Insure that vibrator circuit wiring is in accordance with:
 - a. Figure 5-2, "Vibrator Without Relay."
 - b. Figure 5-3, "Starting Vibrator With Relay Without Delay."
 - c. Figure 5-4, "Sealed Relay Vibrator With Off-Delay."

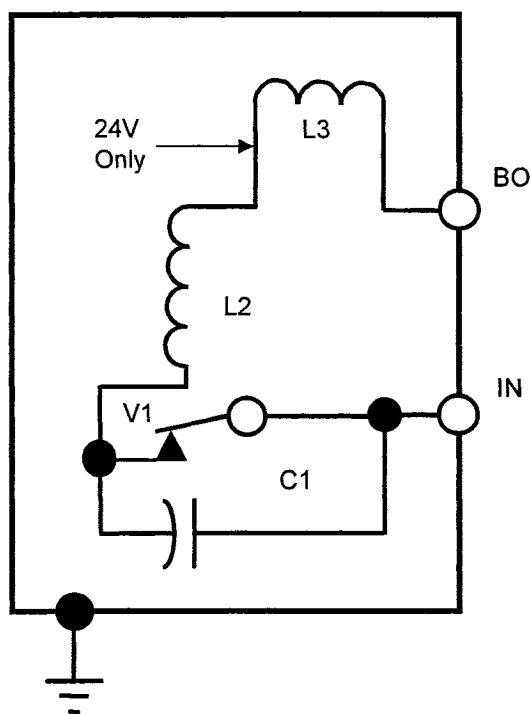

Figure 5-2
Starting Vibrator

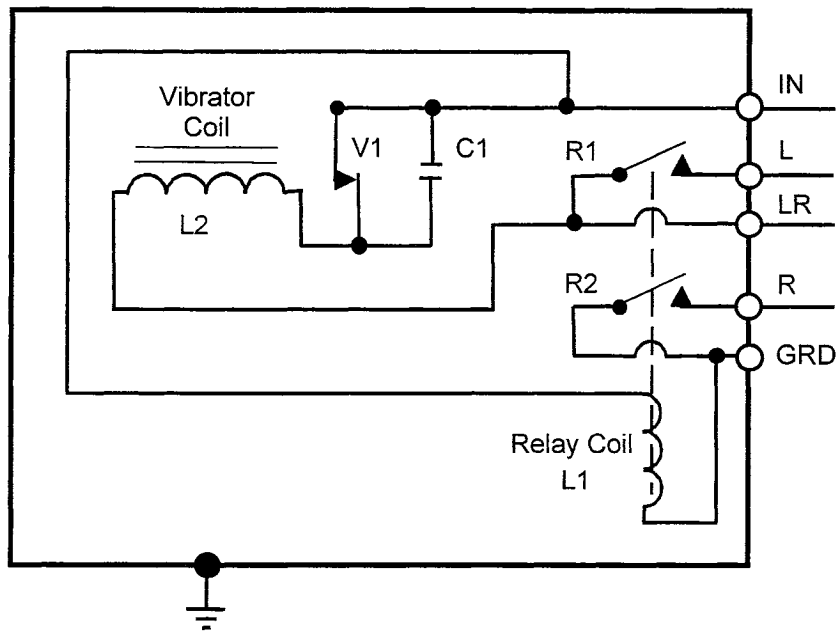

Figure 5-3
Starting Vibrator With Relay

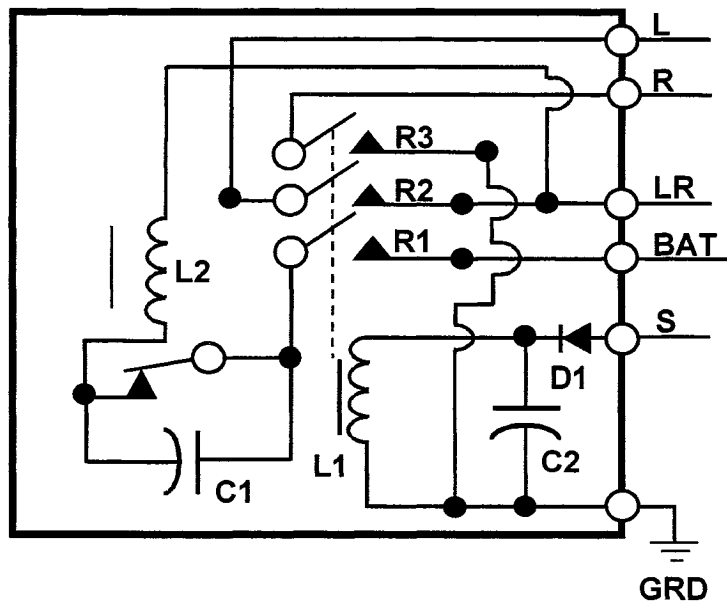

Figure 5-4
Starting Vibrator With Relay And Delay

Relay Vibrator Bushing Repair

If bushing is loose in plate as shown in Figure 5-6, "Bushing Repair" below, secure the bushing as follows:

1. Clean surface of plate around bushing.
2. Reseat bushing to its fullest extent.
3. Use RTV 4135 silicone rubber sealant (Dow Corning Corp., Midland, Michigan 48686), or equivalent to seal terminal bushing to the mounting plate.

Apply a small bead completely around the bottom of bushing to secure the bushing to the plate as shown in Figure 5-5. If RTV is not available, use either Hysol, Epoxi-Patch Kit (general purpose), Hysol Division, Pittsburgh, PA 94565 or Conap, Easyepoxy Kit (K20 general purpose) 1405 Buffalo St., Olean, NY, or equivalent.

Allow a curing time of 24 hours at room temperature of 77° F (or follow manufacturer's recommended curing instructions on the adhesive) before reinstalling the starting vibrator.

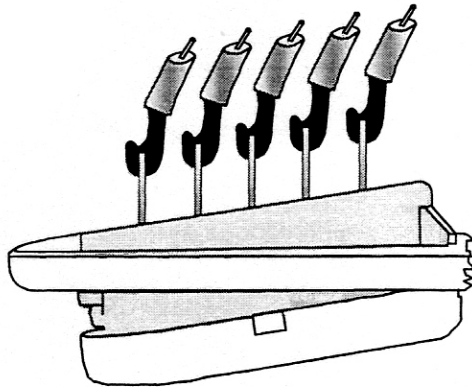

Bushing Loose In Plate

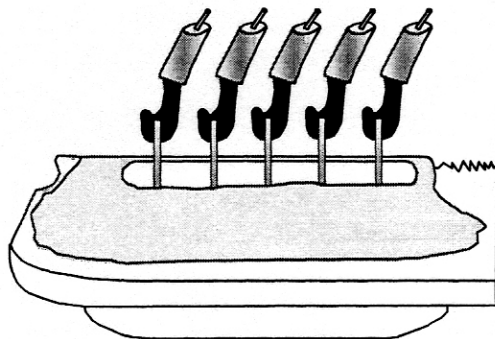

Bushing Seated Correctly

Figure 5-5
Relay Vibrator Bushing Repair

INTENTIONALLY

LEFT

BLANK

Chapter 6

Installation

Installation

The starting vibrator may be installed in any convenient and accessible location. However, it should be installed as close as possible to the starter switch and magnetos to minimize wire length. A cool area removed from the exhaust system and other sources of excessive heat is recommended. Avoid locations which expose the starting vibrator to wheel splash or engine wash down fluids.

Whenever possible, install the vibrator with the plastic cover up and data plate facing down. If the starting vibrator is installed with the cover below the

plate, drill a 1/8 inch drain hole at the low point of the cover. A bracket which forms part of the vibrator mounting plate also facilitates installation of the starting vibrator.

For the 10-400523-1 vibrator only, the vibrator bracket must be bonded to the airframe ground. If necessary, ground vibrator positively by connecting a lead between one of the vibrator mounting plate screws and a section of the airframe which provides a secure common ground. Other vibrators do not require ground bond for the bracket.

INTENTIONALLY

LEFT

BLANK

Chapter 7

Illustrated Parts List

<i>Illustrated Parts List</i>	7-3
<i>Superseded and Discontinued Items</i>	7-3
<i>Starting Vibrators Parts List</i>	7-4
<i>Numerical Parts List</i>	7-6

Illustrations

<i>Figure 7-1, Starting Vibrator Exploded View</i>	7-5
----------------------------------------------------------	-----

INTENTIONALLY

LEFT

BLANK

Illustrated Parts List

10-176487-121	12 Volt without Relay	S-200, S-600 Series Magnetos
10-176487-122	12 Volt without Relay	S-1200 Series Magnetos
10-357487-241	24 Volt without Relay	S-200, S-600 Series Magnetos
10-357487-242	24 Volt without Relay	S-1200 Series Magnetos
10-382775-12	12 Volt without Relay	D-2200, D-3200 Series Magnetos
10-382808-24	24 Volt without Relay	D-2200, D-3200 Series Magnetos
10-400523-1	12 Volt with Relay and Delay	Diamond Katana DA-20
10-400608-121	12 Volt with Relay	S-200, S-600 Series Magnetos
10-400608-122	12 Volt with Relay	S-1200 Series Magnetos
10-400608-123	12 Volt with Relay	D-2200, D-3200 Series Magnetos
10-400608-123	12 Volt without Relay	D-2200, D-3200 Series Magnetos
10-400608-241	24 Volt with Relay	S-200, S-600 Series Magnetos
10-400608-242	24 Volt with Relay	S-1200 Series Magnetos
10-400608-243	24 Volt with Relay	D-2200, D-3200 Series Magnetos

Superseded and Discontinued Items

Old Part Number	Superseded By
10-87928-1	10-176485-121
10-87988-1	*
10-87989-1	*
10-87996-1	10-357487-241
10-87998-1	10-176487-121
10-87999-1	10-176485-241
10-176485-121	10-400608-121
10-176485-122	10-400608-122
10-176485-241	10-400608-241
10-176485-242	10-400608-242
10-176487-241	10-357487-241
10-176487-242	10-357487-242
10-377090-1	*
10-382775-24	10-382808-24
10-382780-12	10-400608-123
10-382780-24	10-400608-243

* Superseding Part Number will be supplied upon request.

Starting Vibrators Parts List

Item	Description	Vibrator Part Numbers													
			10-176487-121	10-176487-122	10-357487-241	10-357487-242	10-382775-12	10-382808-24	10-400523-1	10-400608-121	10-400608-122	10-400608-123	10-400608-241	10-400608-242	10-400608-243
1	Cover	10-391556	1	1	1	1	1	1	1	1	1	1	1	1	1
2	Terminal	10-400041	1	1	1	1	1	1	1	1	1	1	1	1	1
3	Wire, 25 ft.	10-180129-6	AR	AR	AR	AR	AR	AR	AR	AR	AR	AR	AR	AR	AR
4	Bushing-Black	10-382943								1	1	1	1	1	1
5	Bushing-Black	10-382975-14	1	1	1	1	1	1							
6	Bushing-Red	10-382975-11	1	1	1	1	1	1							
7	Terminal	10-400142	2	2	2	2	2	2	5	2	5	5	5	5	5
8	Nut	10-56156	2	2	2	2	2	2	2	5	2	2	2	2	2
9	Washer-Plain	10-52384	2	2	2	2	2	2	2	2	2	2	2	2	2
10	Contact Assembly	10-176470	1	1	1	1	1	1	1	1	1	1	1	1	1
11	Washer-Insulating	10-52383	1	1	1	1	1	1	1	1	1	1	1	1	1
12	Bushing	10-52382	1	1	1	1	1	1	1	1	1	1	1	1	1
13	Screw	10-53179	1	1	1	1	1	1	1	1	1	1	1	1	1
14	Screw w/ Lock Washer	10-35936-4	1	1	1	1	1	1	1	1	1	1	1	1	1
15	Capacitor	10-164418	1	1	1	1	1	1	1	1	1	1	1	1	1
16	Screw	10-92644-42	1	1	1	1	1	1	1	1	1	1	1	1	1
17	Washer-Plain	10-9858	1	1	1	1	1	1	1	1	1	1	1	1	1
18	Washer-Lock	10-92879-42	1	1	1	1	1	1	1	1	1	1	1	1	1
19	Contact Assembly	10-176489	1	1	1	1	1	1	1	1	1	1	1	1	1
25	Screw	*							6	2	2	2	2	2	2
26	Washer-Lock	*							6	2	2	2	2	2	2
27	Relay-12 Volt, DPDT	*								1	1	1			
	Relay-24 Volt, DPDT	*											1	1	1
	Relay-12 Volt, 4PDT	*							1						
28	Screw	*	1	1	2	2	1	2	1	1	1	1	1	1	1
29	Washer-Lock	*	1	1	2	2	1	2	1	1	1	1	1	1	1
30	Plate	*	1	1			1			1	1	1	1	1	1
31	Plate	*			1	1		1							
32	Plate	*			1	1									
34	Insulating Plate	*	1	1	1	1	1	1	1	1	1	1	1	1	1
35	Core	*	1	1	2	2	1	2	1	1	1	1	1	1	1
36	Coil - 12 Volt	*	1	1	2	2	1	2	1	1	1	1			
	Coil - 24 Volt	*											1	1	1
37	Support	*	1	1	1	1	1	1	1	1	1	1	1	1	1
38	Washer - Insulating	10-357482	1	1	1	1	1	1	1	1	1	1	1	1	1
39	Washer - Flat	10-92862-10	1	1	2	2	1	2	1	1	1	1	1	1	1
40	Washer - Insulating	10-357481			1	1		1							
41	Tube, 3 ft.	10-180206-1			AR	AR		AR							
42	Terminal **	10-162579	2	2	2	2	2	2	5	5	5	5	5	5	5

* Not available as a spare

** Supplied as bag parts, not illustrated

Refer to Figure 1, "Starting Vibrator Exploded View" on the following page

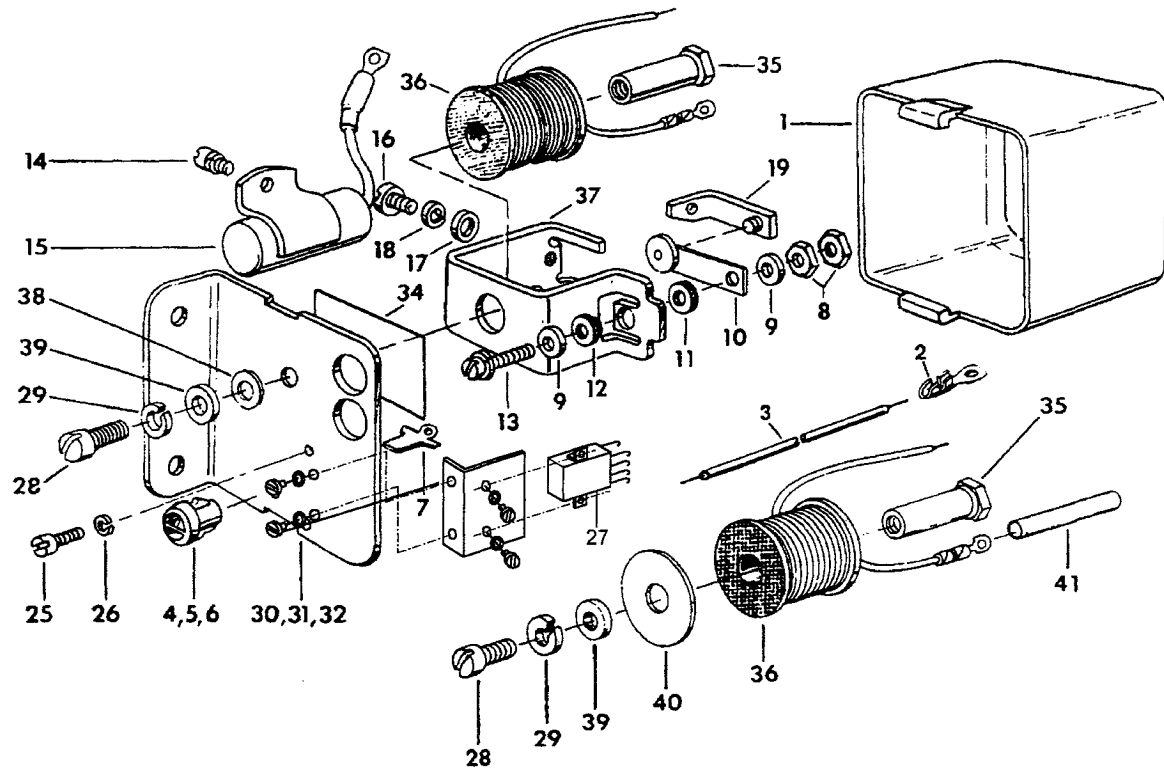

Figure 7-1
Starting Vibrator Exploded View

INTENTIONALLY

LEFT

BLANK

Numerical Parts List

Part Number	Description	Item
10-162579	Terminal	**
10-164418	Capacitor	15
10-176470	Contact Assembly	10
10-176489	Contact Assembly	19
10-180129-6	Wire, 25 ft.	3
10-180206-1	Tube, 3 ft.	41
10-357481	Washer – Insulating	40
10-357482	Washer – Insulating	38
10-35936-4	Screw with Lock Washer	14
10-382943	Bushing – Black	4
10-382975-11	Bushing – Red	6
10-382975-14	Bushing – Black	5
10-391556	Cover	1
10-400041	Terminal	2
10-400142	Terminal	7
10-52382	Bushing	12
10-52383	Washer – Insulating	11
10-52384	Washer – Plain	9
10-53179	Screw	13
10-56156	Nut	8
10-92644-42	Screw	16
10-92862-10	Washer – Flat	39
10-92879-42	Washer – Lock	18
10-9858	Washer - Plain	17

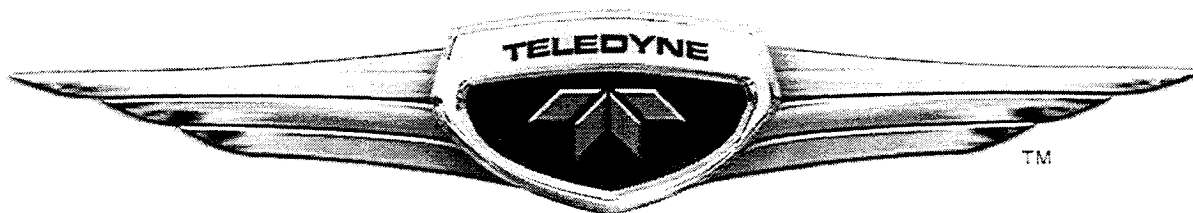

CONTINENTAL MOTORS
A Teledyne Technologies Company

X43003-1

©2001 Teledyne Technologies, Incorporated